

Press the Stop button on the OP for 5 seconds and change parameters below. F4 - F5 - F6 are to fine-tune the cutting system  
 F3 = Film cutting system (1 = ON)  
 F4 = Friction voltage before cutting (Settings between 0 - 255)  
 F5 = Cutting time (10 = 0,1 sec) (Settings between 0 - 255)  
 F6 = Slow time (10 = 0,1 sec) (Settings between 0 - 255)

If the cutting system is not working probably you have switched the two brown wires 9 & 10.  
 After controlling the parameters switch OFF the machine, wait 10 seconds and switch it ON again

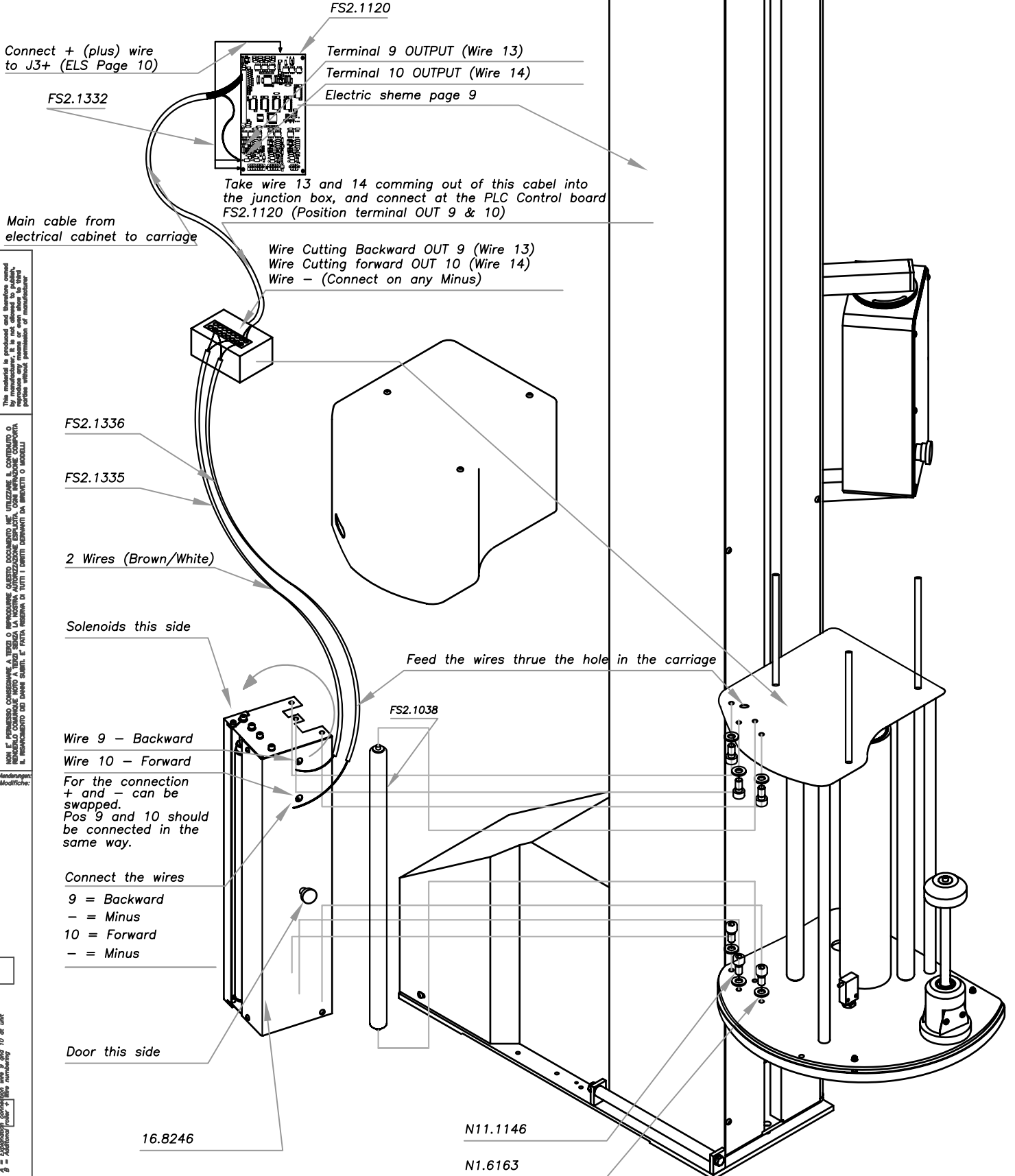

This manual is protected and therefore must be reproduced or modified in any way without the prior written permission of the manufacturer.

NON È PERMESSO COPIARE, A TITOLI O ALTRIMENTI, QUESTO DOCUMENTO, NE UTILIZZARE, SU QUALSIASI FORMA, IL CONTENUTO, IL TITOLO, IL LOGO, IL MARCHIO, O QUALSIASI ALTRA PARTE DELLO STESSO, SENZA IL CONSENSO SCRITTO DEL PROPRIETARIO. È vietata espressamente la ristampa o l'uso non autorizzato.

Änderungen:  
 Modifiche:  
 Änderungen:  
 Modifiche:

A = Änderungen  
 B = Änderungen  
 C = Änderungen  
 D = Änderungen  
 E = Änderungen  
 F = Änderungen  
 G = Änderungen  
 H = Änderungen  
 I = Änderungen  
 J = Änderungen  
 K = Änderungen  
 L = Änderungen  
 M = Änderungen  
 N = Änderungen  
 O = Änderungen  
 P = Änderungen  
 Q = Änderungen  
 R = Änderungen  
 S = Änderungen  
 T = Änderungen  
 U = Änderungen  
 V = Änderungen  
 W = Änderungen  
 X = Änderungen  
 Y = Änderungen  
 Z = Änderungen

Objekt / Oggetto	Pos.	Werkstoff / Materiale	Hersteller / Produttore	Bestandl. Nr. / Elemento Nr.	Bemerkungen / Osservazioni
Installation Cutting device					
D-16.8246.04A-INS					
FROMM					
16.8246-INS					