

FROMM

SEMI – AUTOMATIC SELF PROPELLING ROBOT Wrapping Machine Series FR3xx FR3.1356

Manual OP1-32.2X.XXX.01-EN Version02 / epennings/ ORIGINAL MANUAL © 03/10



INDEX

	<i>Page</i>
1	Machine make - up
2	General
3	Safety instructions
4	Safety devices
5	Warnings
6	Identification Sticker
7	Technical Data
8	Dimensions / Layout
9	Explanation of pictograms
10	Main Components
11	Handeling & Transport
12	Installation
13	Assembly Sequence
14	Control panel
15	Indications
16	Basic operating Instructions
17	Start wrapping Cycle
18	Wrapping Programs
19	Alarms & Errors
20	Insering the film
21	Maintenance Instructions
22	Maintenance sheme & Lubrificants

BE Opgelet!

Leest U in elk geval de gebruiksaanwijzing, vooraleer de machine wordt opgesteld, geïnstalleerd en in gebruik genomen wordt. Daardoor zorgt U voor Uw eigen veiligheid en vermijdt U schade aan Uw machine.

DE Achtung!

Lesen Sie unbedingt die Gebrauchsanweisung vor Aufstellung-Installation-Inbetriebnahme. Dadurch schützen Sie sich und vermeiden Schäden an Ihrem Apparat.

DK OBS!

De bør absolut læse bruganvisningen, inden maskinen opstilles, installeres og tages i brug. Derved beskytter De Dem selv og undgår skader på maskinen.

ES Atención!

Resulta imprescindible leer las Instrucciones de manejo antes de proceder al Emplazamiento/ Instalacion/Puesta en servicio del aparato, con objeto de protegerse a si mismo y evitar el deterioro de la máquina debido a un manejo incorrecto.

FR Attention!

Lisez impérativement le mode d'emploi avant l'installation/la mise en service. Vous vous protégerez ainsi et éviterez des détériorations sur votre appareil.

GB Important!

Read the operating instructions carefully before installation and before using this machine for the first time.

You will avoid the risk of causing harm to yourself or to your machine in this way.

GR Προσοχή!

Πρίν την εγκατάσταση, σύνδεση και αρχική λειτουργία της συσκευής διαβάστε προσεκτικά τις οδηγίες χρήσης.

Έτσι προστατεύετε τον εαυτό σας και αποφεύγετε πιθανές βλάβες συσκευής.

IT Attenzione!

Leggere assolutamente le istruzioni d'uso prima di procedere a posizionatura – installazione - messa in funzione. In questo modo ci si protegge e si evitano danni all'apparecchio.

NO NB!

De må lese bruksanvisningen før oppstilling, installasjon og start av maskinen! Gjør det for å unngå skade på Dem selv og maskinen.

NL Let op!

Lees beslist de gebruiksaanwijzing voor het plaatsen, installeren en in gebruik nemen van uw machine. Dat is veiliger voor Uzelf en U voorkomt onnodige schade aan Uw machine.

PL Ważne!

Przed instalacją maszyny, bądź przed przystąpieniem do pracy z maszyną po raz pierwszy, należy dokładnie przeczytać i zapoznać się z niniejszą instrukcją obsługi.

W ten sposób uniknie się ryzyka mogącego spowodować uraz ciała bądź uszkodzenie maszyny.

PT Atenção!

Leia as instruções de utilização antes da montagem - instalação e - primeira utilização. Assim evita avarias no aparelho.

SE OBS!

Läs bruksanvisningen noga före uppställning, installation och användning. Ni förebygger därmed olycksrisker och undviker skador på maskinen.

FI Huomio!

Tutustukaa huolellisesti käyttöohjeeseen ennen laitteen asennusta ja käyttöönottoa.

Näin välttytte mahdollisilta vahingoilta käyttäessä konetta.

MACHINE MAKE - UP

MACHINE MAKE – UP

THE FR3xx FROMM series is a wheeled robot, which independently rotates around stabilized products to wrap and stabilize them by means of stretch film.

It is controlled by a dedicated electronic control unit including a FROMM-PLC for execution of the various processes.

Particular attention must be paid to charging the robot battery in order to ensure a lifetime as long as possible. (refer to the chapter BASIC OPERATIONS and ASSEMBLY ESQUENCE)

Serial number

Delivery Date

Art.-Nr.	Model	
32.21.110	FR330	OP1/H2200mm/C1/24V/110Ah
32.21.120	FR350	OP1/H2200mm/C2/24V/110Ah
32.21.130	FR390	OP1/H2200mm/C3/24V/110Ah
32.21.140	FR400	OP1/H2200mm/C4/24V/110Ah
32.21.210	FR331	OP1/H2500mm/C1/24V/110Ah
32.21.220	FR351	OP1/H2500mm/C2/24V/110Ah
32.21.230	FR391	OP1/H2500mm/C3/24V/110Ah
32.21.240	FR401	OP1/H2500mm/C4/24V/110Ah
32.21.310	FR332	OP1/H2800mm/C1/24V/110Ah
32.21.320	FR352	OP1/H2800mm/C2/24V/110Ah
32.21.330	FR392	OP1/H2800mm/C3/24V/110Ah
32.21.340	FR402	OP1/H2800mm/C4/24V/110Ah
32.22.110	FR330	OP2/H2200mm/C1/24V/110Ah
32.22.120	FR350	OP2/H2200mm/C2/24V/110Ah
32.22.130	FR390	OP2/H2200mm/C3/24V/110Ah
32.22.140	FR400	OP2/H2200mm/C4/24V/110Ah
32.22.210	FR331	OP2/H2500mm/C1/24V/110Ah
32.22.220	FR351	OP2/H2500mm/C2/24V/110Ah
32.22.230	FR391	OP2/H2500mm/C3/24V/110Ah
32.22.240	FR401	OP2/H2500mm/C4/24V/110Ah

MACHINE MAKE – UP

32.22.310	FR332	OP2/H2800mm/C1/24V/110Ah	<input type="checkbox"/>
32.22.320	FR352	OP2/H2800mm/C2/24V/110Ah	<input type="checkbox"/>
32.22.330	FR392	OP2/H2800mm/C3/24V/110Ah	<input type="checkbox"/>
32.22.340	FR402	OP2/H2800mm/C4/24V/110Ah	<input type="checkbox"/>
<hr/>			
32.22.131	FR390	OP2/H2200mm/C3/24V/110Ah With cutting device	<input type="checkbox"/>
32.22.141	FR400	OP2/H2200mm/C4/24V/110Ah With cutting device	<input type="checkbox"/>
<hr/>			
32.22.231	FR391	OP2/H2500mm/C3/24V/110Ah With cutting device	<input type="checkbox"/>
32.22.241	FR401	OP2/H2500mm/C4/24V/110Ah With cutting device	<input type="checkbox"/>
<hr/>			
32.22.331	FR392	OP2/H2800mm/C3/24V/110Ah With cutting device	<input type="checkbox"/>
32.22.341	FR402	OP2/H2800mm/C4/24V/110Ah With cutting device	<input type="checkbox"/>

MACHINE MAKE - UP

GENERAL

- This manual is only intended for a semi-automatic pallet stretch wrapping machine, mentioned at page one, as delivered by FROMM Stretch Wrapping Division.
- **FOR EVERYTHING IN THIS MANUAL IS VALID, IF APPLIED!**
- Pre- stretching (Stretching out) the film prior to application on the goods reduces the costs of packaging and is easier on the environment. (Available pre stretch depend on the model)
- Refer to chapter for the technical data, which describes the installation in detail and for the complete size of the installation.
- Read carefully at least the chapters **HANDELING AND TRANSPORT** and **INSTALLATION**.
- For safety reasons the entire instruction manual should be read before setting in operation the machine/installation, solving failures and executing maintenance.
- We particularly draw your attention to the chapters **SAFETY INSTRUCTIONS** and **WARNINGS** which point out the intended use and unsafe situations that could not be prevented in the design and manufacture of the wrapping machine.
- It is strictly prohibited to tamper with the machine It is prohibited to feed the machine with unforeseen, corrosive or inflammable products since the machine is not the explosion-proof type.
- The duration of guarantee is provided the following are observed: the use for which the machine was designed, built and protected, in addition to recommendations, information - including matters of general knowledge - details plus the safety and health technical limits notified to by the Manufacturer to the User by virtue of the operating use.
- We cannot accept any claim for warranty if non-original spare parts are utilized.
- If the machine is used beyond its operating limits and if the manufacturer's features are altered in any way, such use is considered **improper**. In this case **MANUFACTURER** is relieved of any liability for injury/damage caused to people/property due to failure to comply with these guidelines.
- For all the aforementioned reasons, we recommend that our customers always notify the Service Department.

SERVICE DEPARTMENT

Please contact, in case of problems:

SPARE PARTS

Spare parts can be ordered from:

SAFETY INSTRUCTIONS



ATTENTION!

The following conditions have always to be satisfied, unless otherwise indicated in other instructions in this manual.

- This wrapping machine has been delivered by FROMM Stretch Wrapping Division and may only be applied for wrapping of pallets / products which meet the requirements as mentioned in the description of the machine in chapter **TECHNICAL DATA**. Any other use of the machine as for the described purpose may cause danger due to damage to the machine and/or the safety of the operator or other persons in the neighbourhood of the machine.
- Read this manual carefully before using the machine
- The machine is not fit with components that involve special decommissioning problems except for the battery.
- In any case all the components must be disposed of by scrupulously complying with the corresponding laws in force in the country in which the machine is used, and only by qualified persons who are capable of assessing possible risks.
- Only personnel trained for the purpose may operate the machine
- Use the emergency stop to halt the machine immediately
- Only trained electricians may perform electrical work on the machine
- When installing the machine, as a precaution, always check that the controls and safety systems are correctly mounted and operating efficiently. If any malfunctions are noted, immediately stop the production cycle and ask the authorized technical service to intervene
- Examine the data-plates. If they are in poor condition, replace them with utmost urgency, strictly and directly contacting the authorized technical service or the Manufacturer
- The requirements, as mentioned in chapter **MAINTENANCE INSTRUCTIONS** should be satisfied during adjustment and maintenance activities
- People should not step on to means of transport, unless indicated clearly otherwise
- People should not find themselves above the means of transport
- Do not place tools and components on the machine
- Safety devices should not be bridged and put out of operation
- The manufacturer will only make the machine ready for operation, when the electrical main connection satisfies the standards applicable in the country of delivery

SAFETY INSTRUCTIONS



- The supplier will do the training of the operating personnel. If not, the training will have to be done properly by the company that takes care of the installation.
- The machines are designed and implemented conforming to the safety laws in force. Consequently, no intrinsic fire risks are envisaged when the machine is used normally
- As such, the equipment provided against the possibility of **fire outbreaks** inside the company are sufficient for any problems caused by the material used for the process
- In the event a fire breaks out and fire extinguishers are used, it is recommended that extinguishers filled only with CO2 be used, so as not to damage both the equipment on the machine and the wiring system
- In the event of **flooding**, it is compulsory that all the power supplies be disconnected before entering the room in which the machine is installed
- In the event the wrapping machine was subjected to a flooding, contact the Customer technical service of MANUFACTURER
- You are strictly recommended not to work in the machine while wearing unsuitable clothing (unbuttoned, ample garments) or personal objects (bracelets, watches, rings, etc.)

ADDITIONAL SAFETY INSTRUCTIONS ROBOT FR3xx**ATTENTION!**

The following conditions have always to be satisfied, unless otherwise indicated in other instructions in this manual.

- The room in which the machine is housed must not have any shadow areas, annoying bright lights or hazardous stroboscopic effects caused by the lighting supplied by the manufacturer.
- The machine can operate in clear air conditions at ambient temperatures of + 5°C to + 40°C. The machine must be used **EXCLUSIVELY BY QUALIFIED PERSONNEL**.
- Before starting work, the operator must be perfectly familiar with the position and functioning of all the controls and machine features. Daily check all the safety devices on the machine.
- Before starting the working cycle, the operator must ensure that there are no **EXPOSED PERSONS** in the **HAZARDOUS ZONES**.
- The areas where the operator stands must always be kept clear and free of oily residues. Any operations that need to be carried out with some of the safety devices disabled must be performed by one person only, and unauthorised persons may not access the machine during this time.
- **IN OBSERVANCE OF Machine Directive 2006/42/EC AND SUBSEQUENT AMENDMENTS AND EN23741, FROMM STRETCH DECLARES THAT THE NOISE EMITTED BY THE MACHINE IN QUESTION FALLS WITHIN THE LIMITS ESTABLISHED BY THE ABOVE MENTIONED REGULATIONS.**
- **HAZARDOUS ZONES**
HAZARDOUS ZONE means any zone within and/or in the vicinity of a machine in which the presence of an exposed person constitutes a risk to the safety and health of that person.
- The **MACHINE** has a number of **HAZARDOUS ZONES** in which the residual risks have been reduced, but not completely eliminated:
Risk of getting trapped.
 Never stand in contact with the product to be wrapped, since there is a risk of falling or getting trapped in the film winding zone.
- **OPERATOR STANDING ZONE**
STANDING ZONE means the zone where the **OPERATOR MUST STAND** during **NORMAL MACHINE OPERATION**.
 Once the robot has been programmed and activated, no further action is required by the operator. Therefore, do not stand in the working area around the product to be wrapped and stabilised.
- **MACHINE STATE:**
STATE means the operating mode (**AUTOMATIC, JOG, MANUAL, TIMED STOP, EMERGENCY STOP ...**) and the condition of the safety devices on the machine (emergency stop pressed, type of "energy source isolation". Regarding isolation of the energy sources, it will be pointed out when the emergency switch needs to be locked and the power connector disconnected.

SAFETY DEVICES



We urge on you again that all safety devices are installed for the safety of the operator etc. and should not be bridged and put out of operation.

Refer to the drawing below for the applied references.

Survey control panel

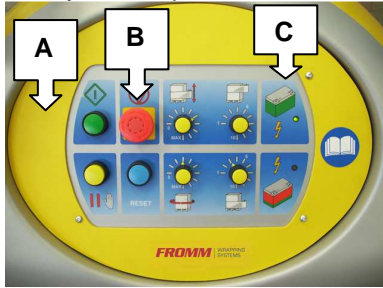

- A = Acoustic signal
- B = Emergency stop
- C = Light On, when the power is On

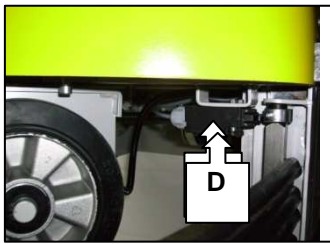

D = Crush-proof guard

D =
This is a mobile crush-proof guard, interlocked by means of a micro switch. Any time underlying foreign matter comes into contact with the guard, it inverts the film carriage's motion and causes the machine to stop in phase.



E = Carriage guard

E = COVER
Do not remove the fixed guards when the machine is running and always refit them after any maintenance operation



	WARNING: ON PARTICULARLY SMOOTH OR SLIPPERY FLOORS, THE ROBOT MAY STOP WITH A SLIGHT DELAY
--	---

	WARNING: DO NOT REMOVE THE SAFETY BUMPER AND ALWAYS REFIT IT AFTER ANY MAINTENANCE OPERATION
--	---

	DO NOT REMOVE THE FIXED GUARDS WHEN THE MACHINE IS RUNNING AND ALWAYS REFIT THEM AFTER ANY MAINTENANCE OPERATION
--	---

WARNINGS

- The mean weighed noise level of the machine is less than 80 dBa. It is possible that, depending on the applied film, during wrapping of the pallets / products incidentally a noise level with a maximum of 80 dBa will be measured. Carrying of noise protecting devices is advised.
- One has to reckon with the possibility that the film (roll) contains an electrostatic charge.
- Utmost caution has to be taken with respect to the complete electrical installation. ONLY trained persons may carry out activities to it, after having taken the required safety measures as mentioned in the chapter **SAFETY INSTRUCTIONS**.
- One has to reckon with the European safety requirements and standards if the machine has to be adapted and thus safety measures or protection covers also have to be adapted.
- Touching the electrical equipment will hazard your personal safety.
- Persons who carry out changes in or adaptations (function, operation or principles) to the machine are fully responsible for those changes and/or adaptations.
- All relevant safety measures should be taken when carrying out any activity on the machine, especially during maintenance activities and solving failures.
Take care that the main switch is switched off (position "0") and locked (If possible), or that the power cable is disconnected in order to prevent other persons in putting in action the machine during your activities.
All the normally valid safety measures or customs with respect to safety should also be taken during those activities.
- Playing with or around the machine may cause dangerous situations with a machine in operation. This playing is never allowed!
- All other prescriptions and laws with respect to working conditions and safety on the working spot should be observed with this machine.
- An acoustic signal device has been installed in the control cabinet, which will be activated first during a short period, as a warning every time before the machine is starting.

EXPLANATION IDENTIFICATION STICKER

An identification sticker with the following information has been mounted at the backside of the base-unit.



- Name of the manufacturer** : FROMM Stretch-wrapping Division.
- Type** : Machine type.
- Serialnr.** : Production number of manufacturer.
- Voltage** : Supply voltage.
- Power** : Used power
- Fuse** : 5 Amp
- Year of manufacture** : Year in which the machine has been built by manufacturer.

Besides, the CE-mark has been placed on the identification plate:

CE-mark

Machine fulfils the applied requirements as mentioned in the CE - machine directives

2006/42/CE Machines
 2004/108/CE
 2006/95/CE

- It is strictly prohibited to remove the identification sticker or to replace it with any other similar one of any type.
- Should the CE mark sticker be damaged for any reason, please notify the MANUFACTURER immediately.

TECHNICAL DATA

Machine	<ul style="list-style-type: none"> - Maximum speed machine - Maximum speed carriage - Capacity - Operational hours - Sealing height FR330 - Sealing height FR331 - Sealing height FR332 	<ul style="list-style-type: none"> 95 M/Min 3,4 M/Min max. 20 pallets/hr. 8 hrs/day, 5 days/week minimum of 2341mm / 92.14" minimum of 2621mm / 103.19" minimum of 2921mm / 115"
Weight	<ul style="list-style-type: none"> - Total weight FR330 - Total weight FR331 - Total weight FR332 	<ul style="list-style-type: none"> approx. 350kg approx. 375kg approx. 400kg
Conditions	<ul style="list-style-type: none"> - Environmental temperature - Environment 	<ul style="list-style-type: none"> + 5 to +40°C clean, dry and non-aggressive
Electrical	<ul style="list-style-type: none"> - Power supply - Control voltage - Battery Voltage - Battery - Charging time - Installed power - Protection class 	<ul style="list-style-type: none"> 1 x 230 V 50/60Hz 24 VAC 24 Volt (2 x 12Volt) 90-100 Ah 8 – 10 hours 1 kW / 5 Amp IP 54
Pallet goods	<ul style="list-style-type: none"> - Max. Pallet dimensions (Length x width) - Min. Pallet dimensions (Length x width) - Height with load FR330 (pallet included) - Height with load FR331 (pallet included) - Height with load FR332 (pallet included) - Dimensions of load outside pallet - Top of load 	<ul style="list-style-type: none"> No Maximum 600 x 600 x 140mm 23.62" x 23.62" x 5,51" min. 500mm / max. 2200mm min. 19,69" / max. 86,61" min. 500mm / max. 2500mm min. 19,69" / max. 98,42" min. 500mm / max. 2800mm min. 19,69" / max. 110.24" max. 20mm / 0,79" per side flat
Stretch-film	<ul style="list-style-type: none"> - LLDPE Material - Spool core diameter - Outer diameter of spool - Film width 	<ul style="list-style-type: none"> Max 27µ / 0.0011" 76 mm / 3" Max. 250mm / 9,84" Max. 500mm / 19,69"
Colors	<ul style="list-style-type: none"> - Mast - Chassis - Machine Cover - Film carriage 	<ul style="list-style-type: none"> : Blue, RAL 5010 : Grey, RAL 9006 : Yellow, RAL 1021 : Grey, GRAFFIT

Should the need arise to work with products having a different nature than the above mentioned ones. It is essential that you contact the technical service of MANUFACTURER in order to receive written authorization.



WARNING : do not use film thicker than 27 microns without consulting the Manufacturer

DIMENSIONS

DIMENSIONS FR3xx



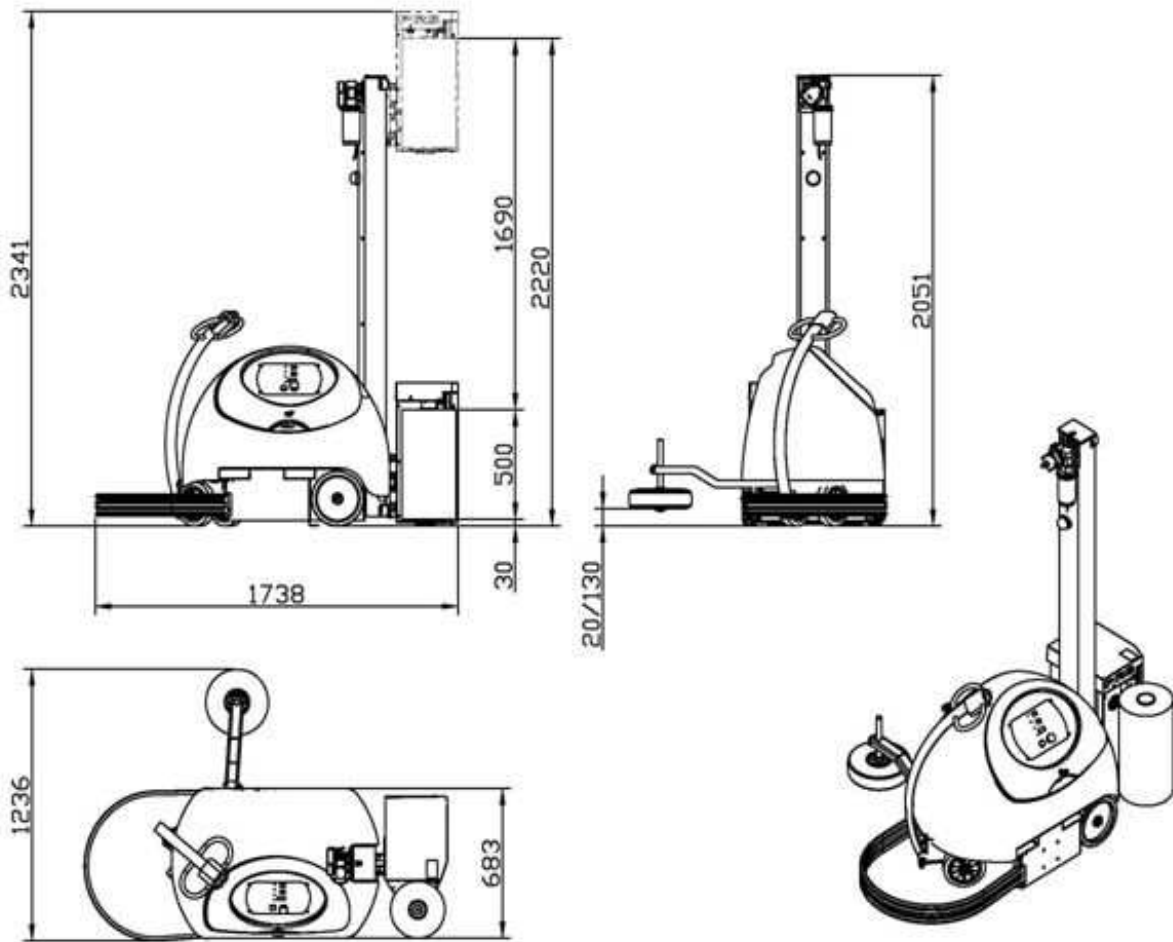

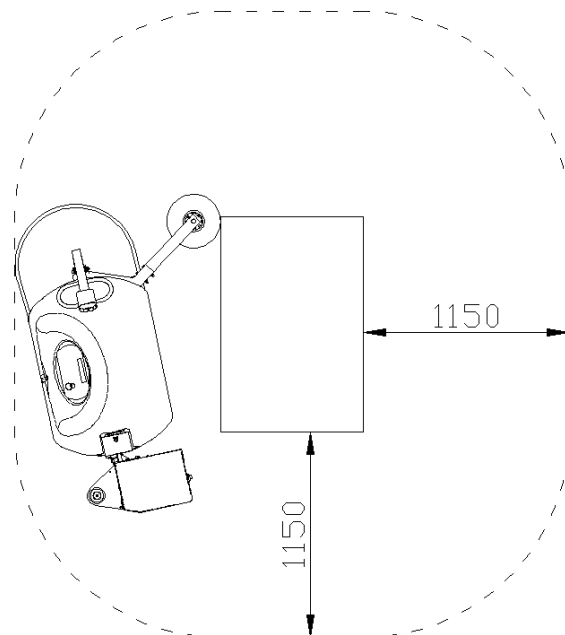

Refer to the LAYOUT on this page for the dimensions.



DIMENSIONS DURING WRAPPING









EXPLANATION OF PICTOGRAMS**ATTENTION!!** (FOR EVERYTHING IS VALID, IF APPLIED!)WARNINGS

 Fig 1	<p>Figure 1: DANGER High voltage present.</p>
 Fig 2	<p>Figure 2: Danger Sign</p>
 Fig 3	<p>Figure 3: Risk of crushing one's hands</p>
 Fig 4	<p>Figure 4: Risk of crushing hands and feet</p>
 Fig 5	<p>Figure 5: Falling hazard</p>
 Fig 6	<p>Figure 6: Sharp objects</p>



COMMAND PLATES

 Fig 7	<p>Figure 7: It is prohibited to pass by within the lifting equipment's ray of action</p>
--	---

EXPLANATION OF PICTOGRAMS

 Fig 8	Figure 8: Do not use bare flames and do not smoke
 Fig 9	Figure 9: Don't access the area while the machine is working
 Fig 10	Figure 10: Don't remove the SAFETY DEVICES
 Fig 11	Figure 11: Don't execute any work before taking off the voltage of the machine
 Fig 12	Figure 12: Truck insertions
 Fig 13	Figure 13: Lifting points
 Fig 14	Figure 14: This identifies situations in which THE SUPPLIER must be contacted

EXPLANATION OF PICTOGRAMS

 Fig 15	Figure 15: Very important guidelines that must strictly be complied with. Otherwise machine operators could be at risk, the consequence of which would be the voiding of any form of warranty and liability on behalf of FROMM PACKAGING SYSTEMS .
 Fig 16	Figure 16: Operations that must never be performed.

CE-MARK

 Fig 17	Figure 17: Machine fulfils the applied requirements as mentioned in the CE-machine directives.
---	---

MAIN COMPONENTS

The installation as delivered consists of the following parts:

- 1- Mast
- 2- Flash Light
- 3- Control cabinet with control panel
- 4- Film carriage
- 5- Robot cover incl. Battery compartment and electronic switch board.

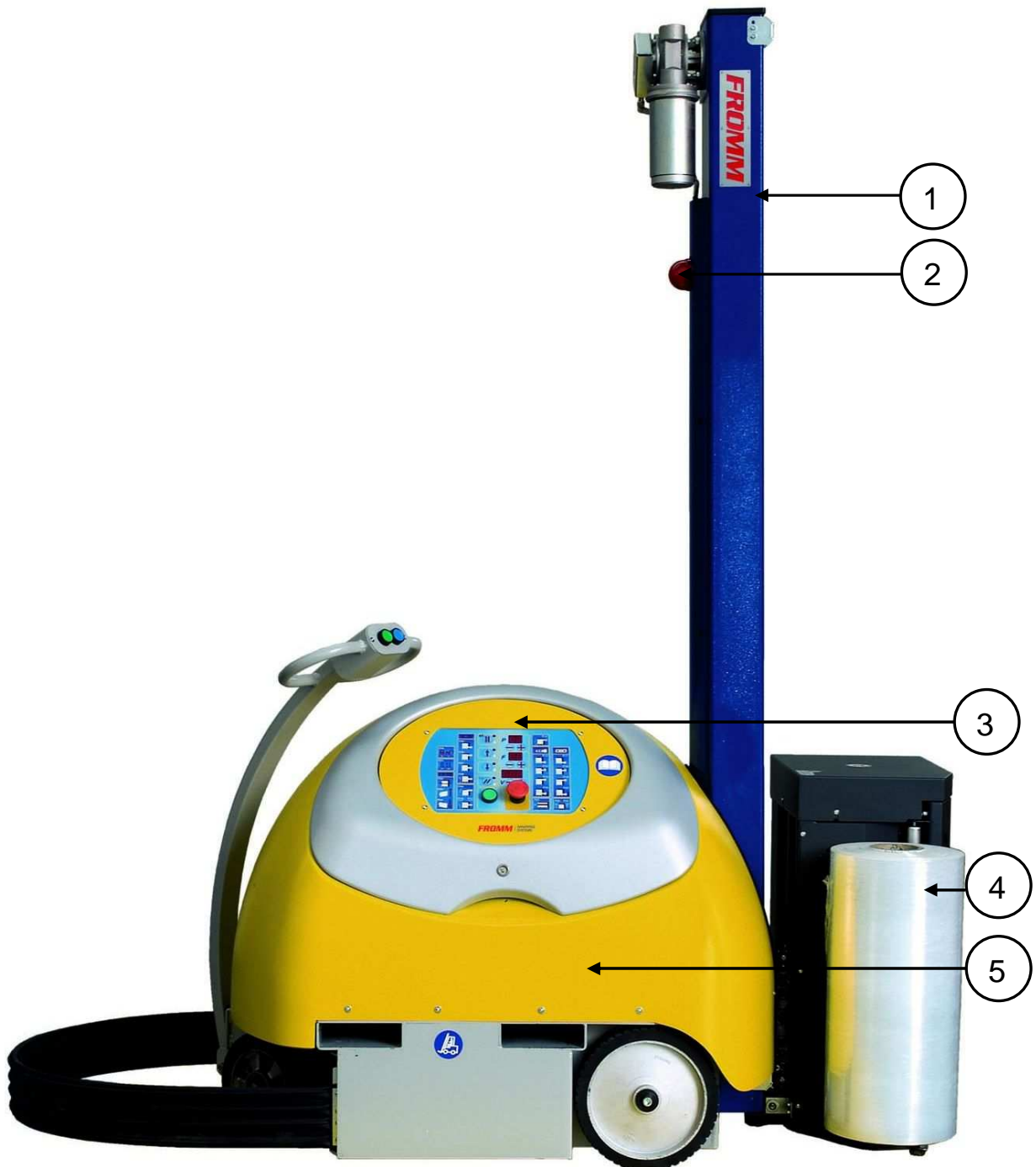

HANDLING & TRANSPORT**ATTENTION!**

All mentioned activities may only be executed under supervision of qualified personnel from the manufacturer or his representatives!

Pay attention that proper hoisting and lifting tools are used for handling of the machine.

The machine is supplied in a wooden crate insulated by plastic air bubble film. It is advisable that two another operators be in attendance on the ground when the machine is moved by means of the mechanical equipment driven by the operator in charge since the size of the machine may prevent a clear view during the various phases of the handling operations.

Depending on weight, dimensions, location of machine on the vehicle, available installation space lifting methods and points suitable for the operations described below must be used, fully observing the current safety and health laws and the Manufacturer's recommendations.

Lifting and handling of packing in a wooden crate by crane

- use a crane and sling of sufficient strength
 - bring the vehicle near to the lifting pallet
 - pass the sling (and/or ropes - chains) around the case in the positions indicated by the external markings (1);
- First check that the case - sling/hook (2) are well secured, then carefully lift the case and place it in the designated area, moving it gently.

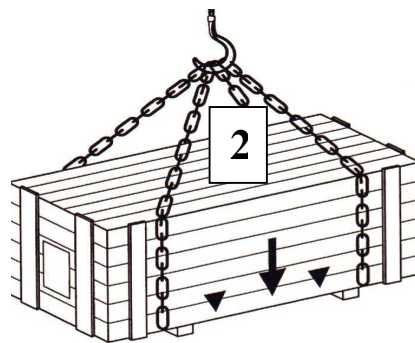
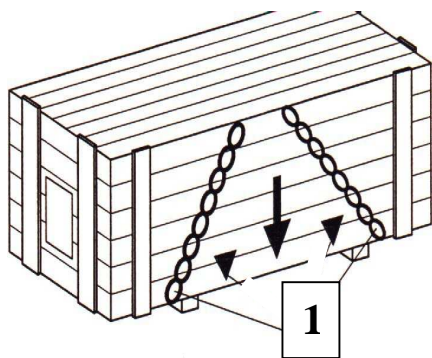

HANDLING & TRANSPORT



Lifting and handling of packing in a wooden crate by fork-lift truck

Lifting and transport must be affected by a fork-lift truck suitable to bear the weight of the machine, its accessories and packing.
Always check in advance that sufficient space is available for the operations.

- slide the forks (1) of the truck under the casels support base, in line with the indicator-marks printed (2).
- lift the load after ensuring it is stable, and transport it to the area in which packing is to be removed, avoiding jerks and dangerous cambers.

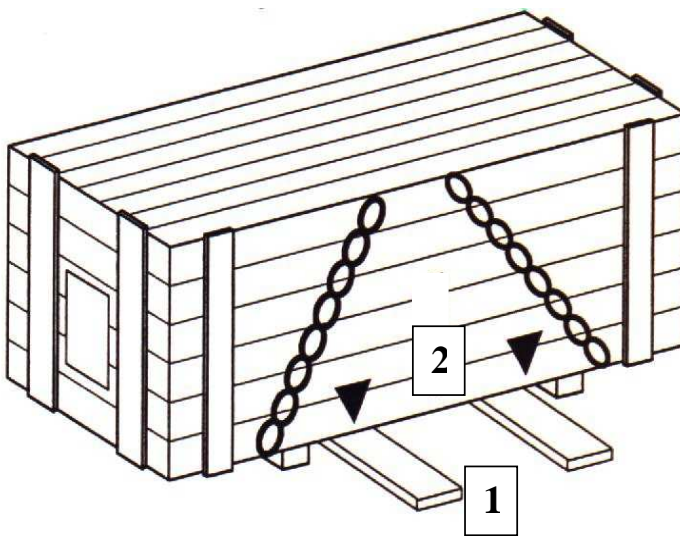

Following measures have to be taken for transport and storage of the machine:

- One has to take care for a suitable storage environment respectively packaging during long-term storage.

Drag bands etc., if used, in order to attach several parts may never be tightened over vulnerable parts, such as control panel, ventilation grills, etc.).

Handling the unpacked machine

Should any machine components be shipped together with the machine, handle them adopting all safety precautions



insert the forks of the suitable lifting equipment within the specific guides (1)



Machine storage

The machine and any components packed together with it are protected by a plastic covering that does not guarantee long storage times.

The machine must never be stacked nor is it capable of supporting external loads.

INSTALLATION INSTRUCTION

ATTENTION!

All mentioned activities may only be executed under supervision of qualified personnel from the manufacturer or his representatives!

Refer to layout in **SAFETY DEVICES** for mentioned position numbers.

General guideline

Always check in advance that the minimum conditions for machine placing and operation are observed, in particular: ambient conditions (suitable floor), temperature, humidity, lighting and suitability of the designated area.

Installation in rooms subject to the risks of flooding, explosion and fire is strictly forbidden.

The area necessary for installation of the wrapping machine is the area according to the dimensions on the layout plus enough space for installing and working on the machine.

Installation must be executed by qualified personnel, directly coordinated by the authorized Technical Service, fully observing the instructions that follow, in addition to current safety and health laws.

As a precaution, always check for any damage caused during transport and handling work. If necessary, contact the Manufacturer directly.

Temperature

For safety make sure the machine is operating at ambient temperature in the range +10°C to +30°C. If other values are measured, contact the Authorized Technical Service with utmost urgency.

Work areas

It is strictly forbidden to locate and/or use the machine if the ambient conditions are liable to cause risks of explosion or inflammability.

Ensure that the following are not present: dust concentration, gas, dangerous fumes and particles, electrostatic fields, excessive electro-magnetic flow, or anything else that might be harmful to persons so exposed or to the efficient running of the machine.

In any event, observe the current safety and health laws.

The machine should be placed on a flat, rigid, vibration-free concrete floor

Never access the high parts of the machine improperly.

Energy sources

The client must provide a cable suited for the required supply voltage up to the control cabinet, of which the diameter of the conductors can manage the total of the required power as mentioned in chapter **TECHNICAL DATA**

The wrapping machine should preferably be connected to the customer's supply voltage wall socket with a connecting cable with a standard CEE-plug, being fused with a 16A-fuse (slow).

For the correct plug check chapter **TECHNICAL DATA**

A main switch preceding the plug has to be provided by the customer, if necessary.

The mains supply must satisfy the applicable standards, such as permitted voltage fluctuations, ripple-generation, reduction of high harmonics, etc.

INSTALLATION INSTRUCTION



ATTENTION!

All mentioned activities may only be executed under supervision of qualified personnel from the manufacturer or his representatives!

During maintenance, repair or adjustment operations, the emergency buttons on the control panel must always be activated and the battery disconnected.

FOR EVERYTHING IS VALID: IF APPLIED!

- **Safety bumper unit:**

Undo the screws (1), fit the bumper unit (2) as shown in the drawing and then screw the screws (1) back in through the holes (3).

- **Feeler wheel unit:**

Undo the screws (4), fit the wheel unit (5) as shown in the drawing and then screw the screws (4) back in.

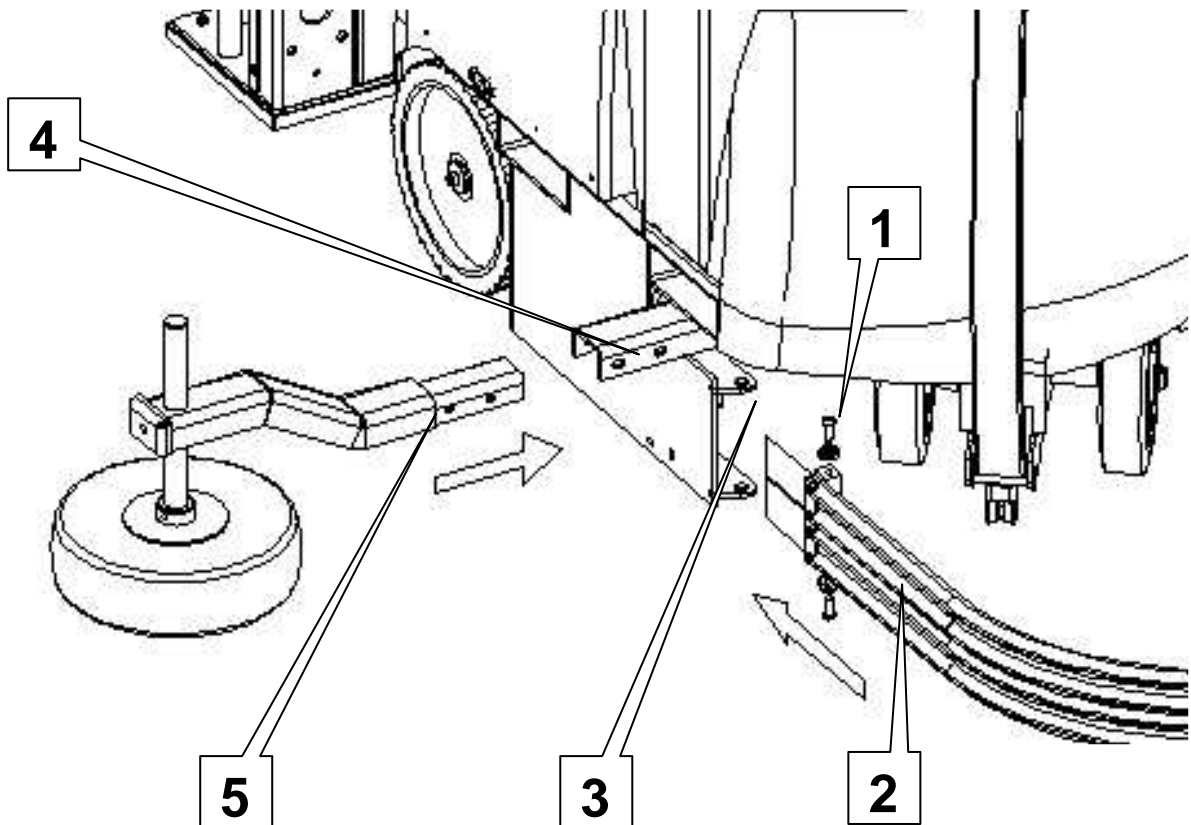

ASSEMBLY SEQUENCE



ASSEMBLY SEQUENCE

1. Check the functionality of the EMERGENCY SWITCH (Fig 1)



Fig 1

The machine is equipped with a safety device consisting of a series of electromechanical contacts that deactivate the motor when the emergency button is pressed. The machine safety devices are activated with the emergency button that converges in this device, which by means of a REDUNDANT and AUTOMATIC CONTROL function on the intermediate relays on which the emergency switches rest, activates a safety circuit that stops the main motor. This assures that the machine stops immediately from all points of operating condition.

C1 Carriage: delivers film during wrapping adjusting the film application tension. The tension is adjusted by a roller fitted with a mechanical brake which can be manually adjusted with a knob on the carriage.

2. Carriage C1

With this carriage, the tension with which the film is applied to the pallet can be adjusted. The carriage **C1** is composed of a rubber-coated roller (1) and a roller (2) with mechanical brake. Operating the knob (3) the braking action is adjusted and, consequently, the film tension. Upon starting, the film must be loaded on to the carriage. Insert the roll (5) on to the centring pin (4). Run the film between the rollers (1) & (2), following the path shown in Figure A. Diagram A is also shown on the carriage. The symbol with the triangles identifies the side of the film on which the adhesive (if present) is applied.

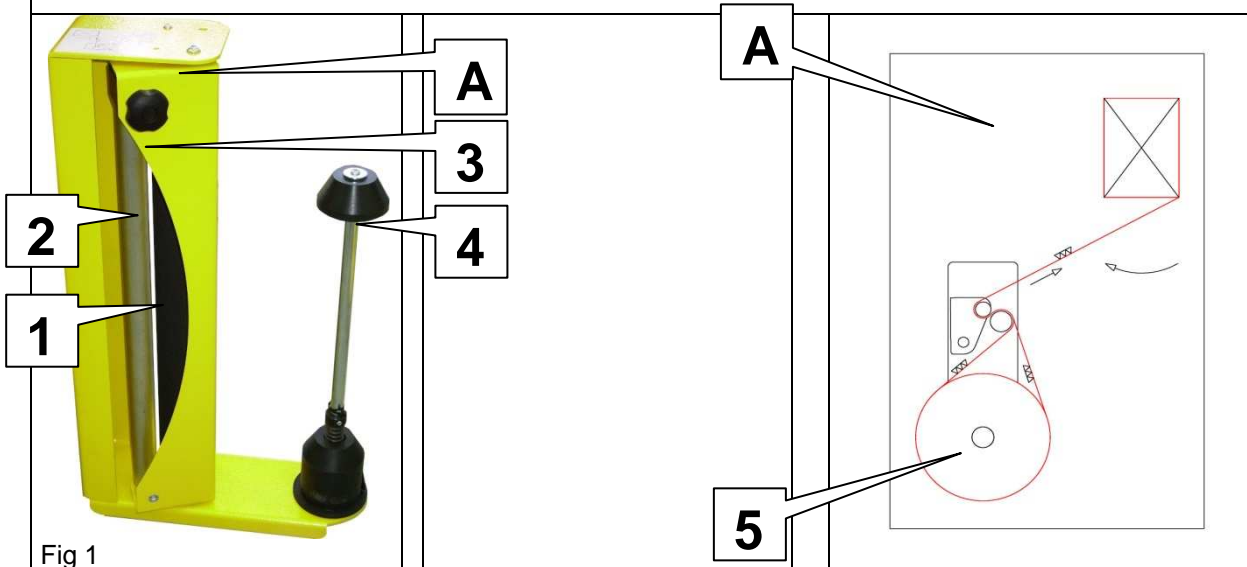

Fig 1

ASSEMBLY SEQUENCE



C2 Carriage: delivers film during wrapping adjusting the film application tension. The tension is adjusted by a roller fitted with an electromagnetic brake. With OP1 the tension can be manually adjusted with a knob on the carriage. With OP2 the tension can be adjusted via the machine operating panel.

3. Carriage C2

The film carriage 2, is composed from a rubber-coated roller (1) in combination with electromagnetic brake and idle rollers (2).

Operating the knob (3) or adjusting the OP, the braking action is adjusted and, consequently, the film tension.

Upon starting, the film must be loaded onto the carriage. Slide the roll (4) onto the core holder of the carriage. Feed the film between the rollers (1) & (2), following the path shown in Figure A. Diagram A is also shown on the carriage.

The symbol with the triangles identifies the side of the film on which the adhesive (if present) is applied.

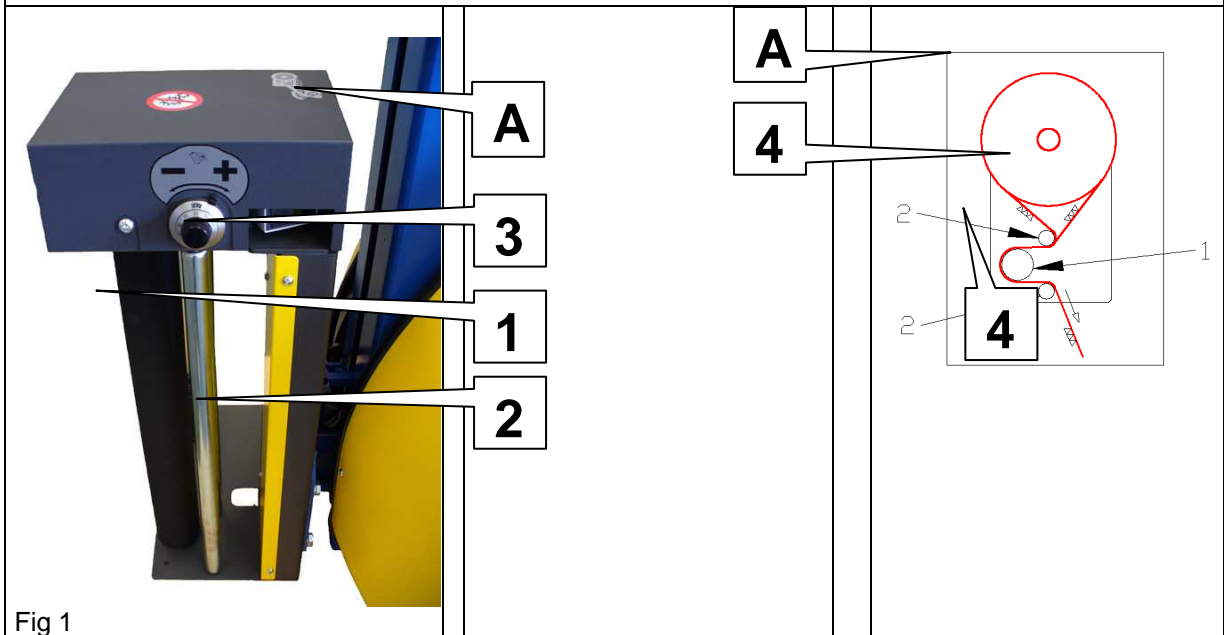

Fig 1

ASSEMBLY SEQUENCE



C3 Carriage: Carriage with one motor pre-stretch system.

The film can be pre-stretched by means of a mechanical control generated by a pair of gears (fixed mechanical ratio). The application tension is manually adjusted and controlled by a sensor which measures its value.

OP1: Tension can be changed by adjusting a knob on the carriage

OP2: Tension can be changed by adjusting the settings on the operating panel

4. Carriage C3

With this carriage version, the tension with which the film is applied to the pallet can be adjusted using the knob (5) or with OP2 via the Operating panel

This carriage allows pre-stretching the film according to fixed ratios determined by interchangeable gears.

The pre-stretch ratios usable are:

- 150% (1 metre of film is pre-stretched to a length of 2.5 metres).
- 200% (1 metre of film is pre-stretched to a length of 3.0 metres).
- 250% (1 metre of film is pre-stretched to a length of 3.5 metres).

The carriage is fitted with a sensor (4) connected to the out-feed roller, which measures the tension of the film applied to the pallet, and a knob (5) or (OP) to adjust this value.

A specific circuit board integrates the signal of the sensor (4) and the adjustment set with the knob (5) or (OP) in order to dynamically control the speed of the pre-stretch roller drive motor and thus the film tension.

The carriage is fitted with a gear-motor which drives three rubber-coated rollers (1), (2) and (3) by means of toothed gearing. The different transmission ratios generate different speeds of the rollers (1), (2) and (3) creating the pre-stretch action.

The carriage also features a set of 3 idle rollers which are used to increase the winding angle of the film on the rubber-coated rollers.

Upon starting, the film must be loaded onto the carriage.

Slide the roll (7) onto the centring pin (8). Open the door and run the film between the rollers following the path shown in Figure A. Diagram A is also shown on the carriage. Close the door making sure that it is properly locked.

The symbol with the triangles identifies the side of the film on which the adhesive (if present) is applied.



Fig 1 = OP1

Fig 2 = OP2

ASSEMBLY SEQUENCE



C4 Carriage: Film carriage with a two motor pre stretch system.

OP1: Pre-Stretch can be changed by adjusting a knob on the carriage (6)

OP2: Pre-Stretch can be changed by adjusting the settings on the operating panel

The application tension is manually adjusted and controlled by a sensor which measures its value.

5. Carriage C4

With this carriage version, the pre-stretch and film tension can be adjusted via a knob on the carriage OP1 or via the operating panel OP2

The pre-stretch can be variable adjusted from 150% upto 400% pre-stretch.

The carriage is fitted with a sensor (4) connected to the out-feed roller, which measures the tension of the film applied to the pallet, and a knob (5) or (OP) to adjust this value. A specific circuit board integrates the signal of the sensor (4) and the adjustment set with the knob (5) or (OP) in order to dynamically control the speed of the pre-stretch roller drive motor and thus the film tension.

Upon starting, the film must be loaded onto the carriage.

Slide the roll (7) onto the centring pin (8). Open the door and run the film between the rollers following the path shown in Figure A. Diagram A is also shown on the carriage. Close the door making sure that it is properly locked.

The symbol with the triangles identifies the side of the film on which the adhesive (if present) is applied.



Fig 1 = OP1

Fig 2 = OP2

ASSEMBLY SEQUENCE

**6. Adjustment reading arm**

The reading arm, on which the wheel that follows the outline of the product to be wrapped is mounted, is subject to two adjustments:

a) Wheel height

Undo the screw (1), raise or lower the wheel pin (2) as shown in the drawing, position the wheel so that it runs around the pallet without depressions and/or protrusions, then tighten the screw (1).

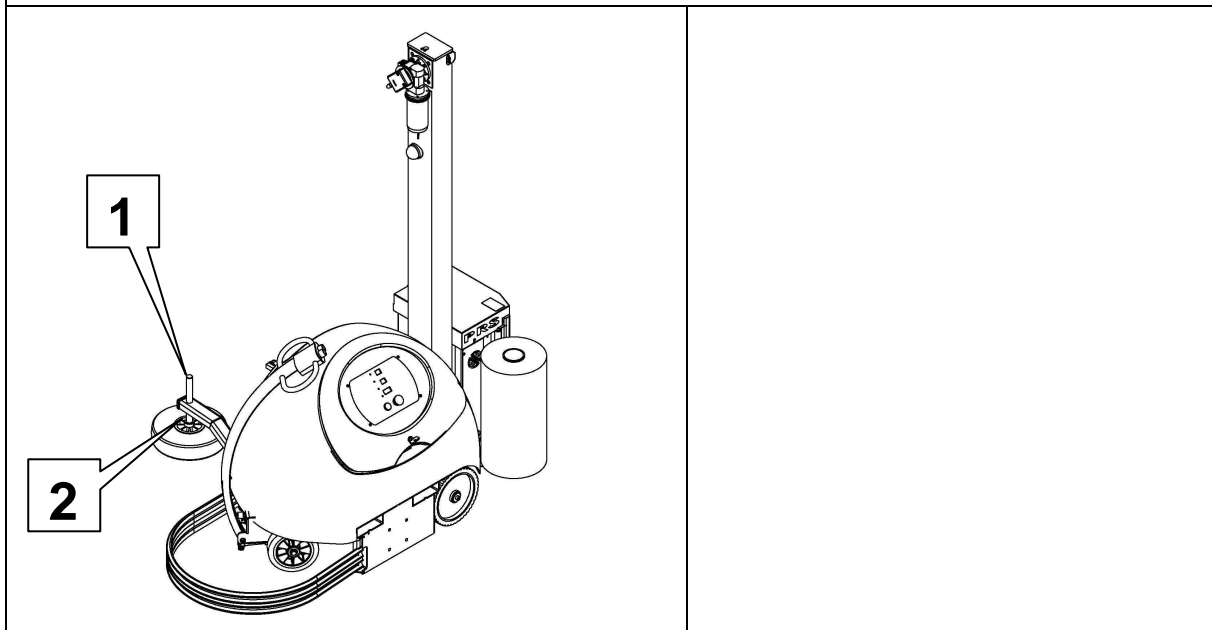

ASSEMBLY SEQUENCE

**7. Steering force**

The arm steering or closure is controlled by a spring (3) coupled to a bracket (4) secured to the steering arm.

The bracket (4) can be set in different positions (5) to adjust the spring tension.

To change the position, release the bracket (4) pulling it by the tab (6) and reset it in the desired position.

A more rigid spring results in:

- Greater steering force
- Greater driving arm rigidity during manual movements
- The risk of lightweight pallets moving on slippery flooring.

A less rigid spring results in:

- Reduced steering force
- Reduced driving arm rigidity during manual movements
- The risk that the robot does not correctly follow the outline of the pallet during high-speed wrapping.

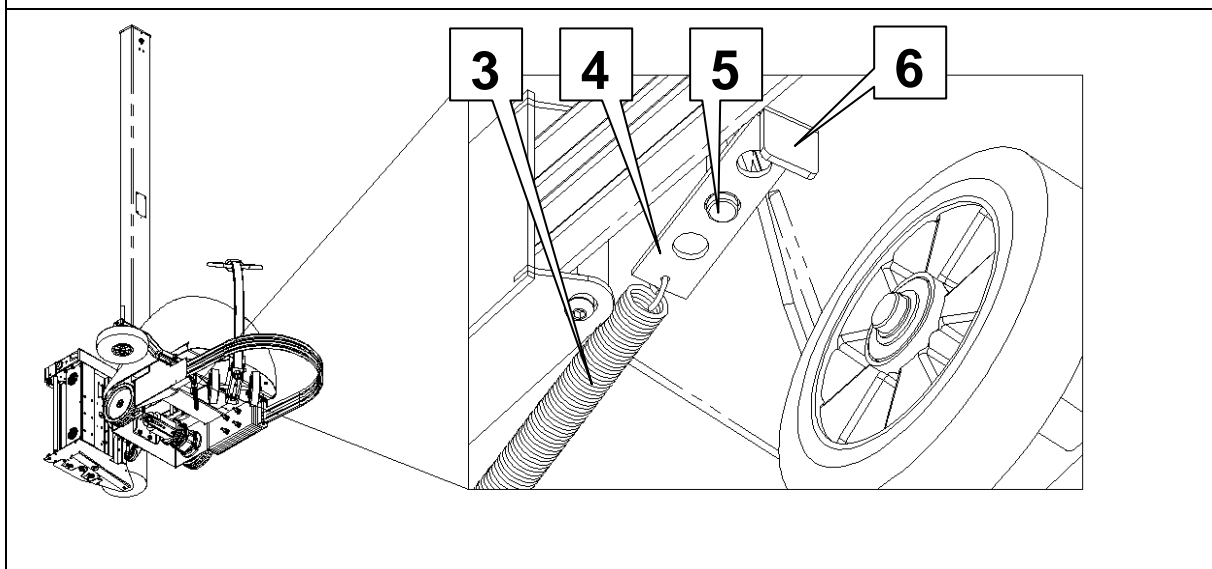

ASSEMBLY SEQUENCE



8. Pallet top overlap adjustment with OP1

The overwrap at the top of the packaging is determined by the position of a bridge A fitted to a jumper located on the rear of the control panel:

- bridge fitted to jumper 1 =
The carriage stops ascent 9 seconds after the photocell is uncovered.
- bridge fitted to jumper 2 =
The carriage stops ascent 6 seconds after the photocell is uncovered.

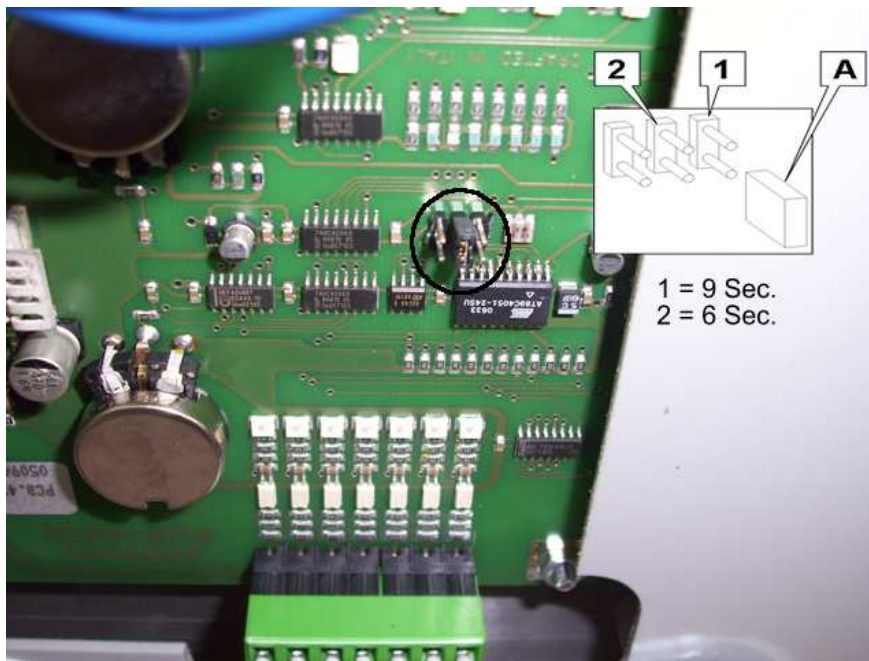

ATTENTION!

After the first installation

Follow procedure below before starting the machine

- Control if the emergency button is free
- Turn on the machine
- Wait 5 seconds and then make the first run in manual mode
- If the machine is running, follow procedure below

After installation or maintenance of the machine follow procedure below to check the efficiency of the safety devices, such as:

- ✓ **The interlocking of the mobile shock proof guard**
- ✓ **Emergency button**

Check for the efficiency of the interlocked shockproof flexible guard

- start the machine
- activate the interlocked operator guard

Check that the machine stops within a few fractions of a second

Check for the efficiency of the mushroom-head button

- start the machine
- press the emergency mushroom-head button

Check that the machine stops within a few fractions of a second

CONTROL PANEL

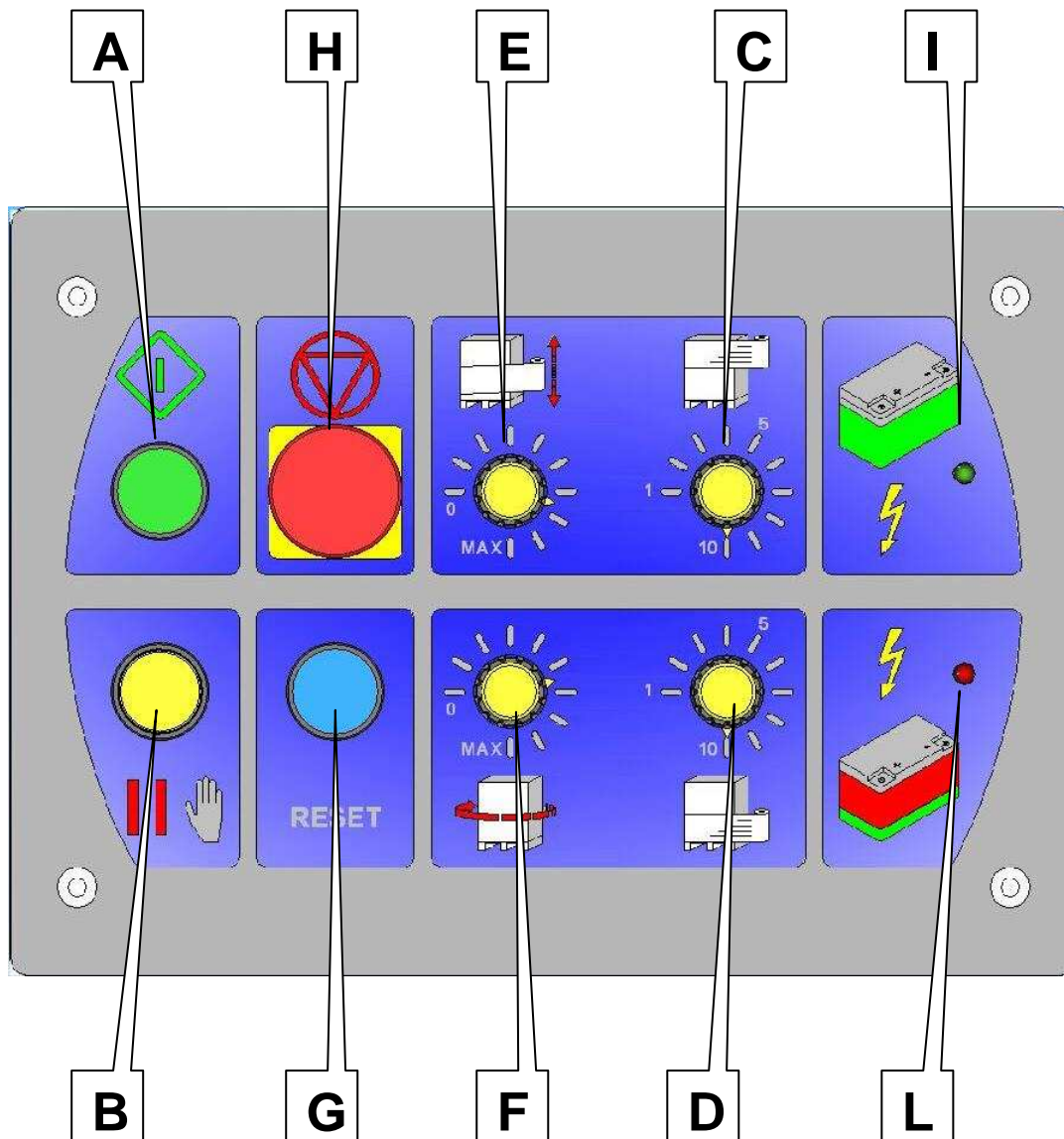

CONTROL PANEL

Figure 1: Console FR33x Generation V01 (Operating panel ONE)

- A = **Wrapping cycle start button**
- B = **Wrapping cycle stop button and manual carriage ascent/descent (button held down)**
- C = **Knob to set the number of extra wraps around the top**
- D = **Knob to set the number of extra wraps around the bottom**
- E = **Knob to adjust the carriage ascent/descent speed**
- F = **Knob to adjust the robot rotation speed**
- G = **Button to reset the machine upon starting or after an emergency stop**
- H = **Emergency stop or machine shutdown button.**
- I = **Battery charged signal LED**
- L = **Battery flat signal LED**

INDICATIONS**START-UP CYCLE ACTIVE**

An acoustic signal device has been installed in the control cabinet, which will be activated first during some seconds as a warning every time before the AUTOMATIC PROGRAM is executed.

The operator will thus be able to leave the danger zone before the machine starts to operate.

The machine will only start to operate after this period has been elapsed.

RESET MACHINE

The automatic program of the wrapping machine is interrupted and a failure indication will be displayed on the console, when the emergency stop is activated or any other failure is detected.

Wrapping can only be started again after pushing reset on the control panel. Thus, the failure is reset and the control voltage is activated again, assuming that the mains switch still has been switched on. The cause of the failure has to be solved first, of course.

BASIC OPERATING INSTRUCTIONS

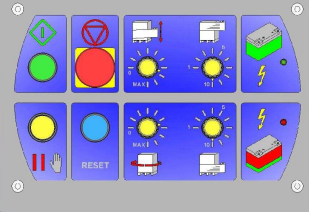

 <p>Left = 1 Right = 2</p>	<p>Using the buttons (1) and (2), move the robot alongside the product resting the reference wheel against it and make sure that the robot is positioned parallel with one of the sides of the pallet to be wrapped at a distance between 30 and 50 cm.</p> <p>From the opposite side of the stretch carriage extract the end of the film and attach it to the bottom of the product to be wrapped.</p>
---	---

 <p>Fig 1</p>	<p>On the control panel (1) set the desired number of extra wraps around the bottom and top and press the green START button. The wrapping operation will automatically be carried out.</p>
--	---

STARTING AND STOPPING OF THE ROBOT WRAPPING CYCLE

Automatic run mode with settable cycles

Activate this run mode, after the machine has been turned on and the safety conditions have been complied with, by pressing the START pushbutton provided that the corresponding work cycle has been set via the pushbutton panel.

- Check for the charge condition of the battery on the control panel
- If the battery was charged beforehand, disconnect the battery charge cable from the socket
- Check that the reel is present on the corresponding reel-holding shaft and that the film's path is correct as shown in the diagram
- Check for the position of the feeler wheel and adjust it, if need be, along the sliding shaft using the lock screw
- Grasp the handlebar and press the forward start pushbutton
- Set the feeler wheel against the product arranged on the pallet
- Manually remove the lead edge of the film from the reel and attach to one of the pallet's corners
- Set the wrapping cycles on the control panel according to the modes outlined in
- Press the START pushbutton
- when the wrapping cycle is finished, manually cut the film and set the adhesive side against the pallet
- the pallet is ready to be picked up

ATT. The acoustic signal is active during approximately 3 seconds before the automatic wrapping cycle will be executed. The machine will only start to operate after this period has been elapsed.

N.B. The automatic wrapping cycle is only started, if the start conditions are fulfilled.
A failure indication is displayed, if not all start conditions are fulfilled.
The start conditions for the automatic wrapping cycle are:

- One of the WRAPPING PROGRAMS should be selected;
- Photocell "pallet height" should be activated;
- Emergency stop not activated;
- The interlocking of the mobile flexible strap;
- No failure detected;

Immediate stop

This stop is commanded as follows:

- By pressing the stop pushbutton
- By pressing the emergency mushroom-head button
- By pressure exerted on the front flexible strap
- By the presence of an alarm that commands the immediate stop.

This stop mode envisages:

- The immediate stop of machine

NOTE: with this type of stop the machine can restart from the operating point in which it had stopped by, pressing the start button.

WRAPPING PROGRAMS

1. Double wrapping

The complete (double) wrapping program will be executed with this function. After completing the pre-set number of bottom wraps the film carriage will go upwards, then it halts to lay the top wraps, while the machine keeps running, and then it will go downwards again. Another number of pre-set bottom wraps is laid, after which the machine will halt. Now the film can be cut and the pallet can be transported.

INSERTING THE FILM

Place the new film reel (direction of unwinding depends on the side on which the cling is found).

Guide the film through the brake system according to the subjoined drawing.

Arrows on the inside of the rol means:

CI = CLING INSIDE

The film has to be guided through the brake system in this way when applying a "differential cling"-film with the cling on the inside of the film when unwinding the film from the film reel.

Arrows on the outside of the rol means:

CO = CLING OUTSIDE

The film has to be guided through the brake system in this way when applying a "differential cling"-film with the cling on the outside of the film when unwinding the film from the film reel.

The way of guiding the film through the brake system when applying a "double sided cling"-film is basically not relevant.

Stretchfilm

- LLDPE Material	Max 35 µ / 0,000138"
- Spool core diameter	76,2 mm / 3"
- Outer diameter of spool	Max. 250 mm
- Film width	Max. 500 mm

MAINTENANCE INSTRUCTIONS FOR OPERATORS**SAFETY!**

- First switch off the main switch and lock it before carrying out maintenance on the installation.
- Take care, that other persons cannot put the installation in action.
- Take care, that the protection covers, etc. are remounted when putting the installation in action again.

The installation will have a long operational life due to preventive maintenance. This means, that the various parts of the installation have to be monitored on a weekly, monthly, semi-annually or annually schedule.

The operational lifetime is influenced by the environmental conditions. The indicated maintenance frequency is valid for normal operation conditions (8 hrs per day, 20° C, clean environment). One is advised to increase the maintenance frequency under more severe conditions. Keep rotating parts free from dirt.

REMAINDER OF THE FILM

The machine has to be cleaned every day

Never use solvents to clean the machine. To remove dust or particles deposited during the size changeover operations, never use compressed air: only use rags and aspirators.

Check if any film and packaging remainder are present in the brake system and remove it.

MAINTENANCE INSTRUCTIONS FOR OPERATORS



DAILY

Particular attention must be given to the charging of the Robot battery in order to ensure a long lifetime. The electronic control unit also incorporates the battery charger which operates under a tight control of the main electronic control unit.

The frequency with which the battery charger must be charged depends on the machine. The most important rules to preserve battery life are:

- Do not leave the batteries half charged or fully discharged for a long period.
- Charge the batteries when the operating panel indicates that the battery is discharged. Extended use when batteries are discharged can cause irreparable damage.

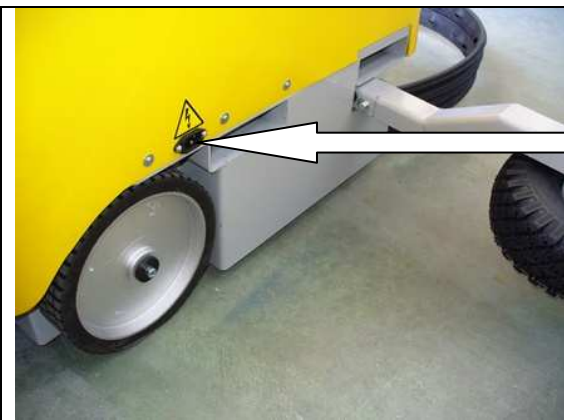

Figure 1

How to recharge:
Connect the tension cable to the machine (Fig 1) and next to the electrical socket. Leave the Robot under charging.



Figure 1

After connecting the plug the process of charging will start in a few seconds. If the charging will be interrupted, the charging will re-start from the initial point of charging, when the connection is re-stored.

The green LED indicates that the charging has been finished with success.

For any other reporting refer to the technical manual of the charger.

WEEKLY

Cleaning. Using only isopropyl alcohol and a non-stringy cloth, thoroughly clean off any trace of dirt from all the working and transport surfaces of the machine, as dirt may cause surface friction and sliding problems. Where appropriate use only a cloth soaked in hot water.

MAINTENANCE INSTRUCTIONS FOR OPERATORS



HALF YEARLY

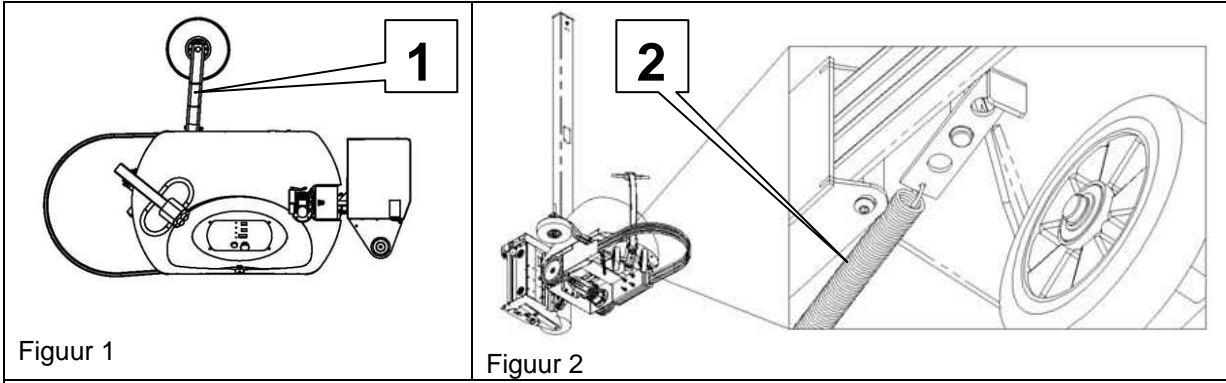

Figuur 1

Figuur 2

Check that the feeder wheel arm (1) always returns in HOME position. If not replace the spring.

Check the status for wear and tear of drive and guide wheels and the rubber coated roller of the roll-holder carriage; if necessary replace them.

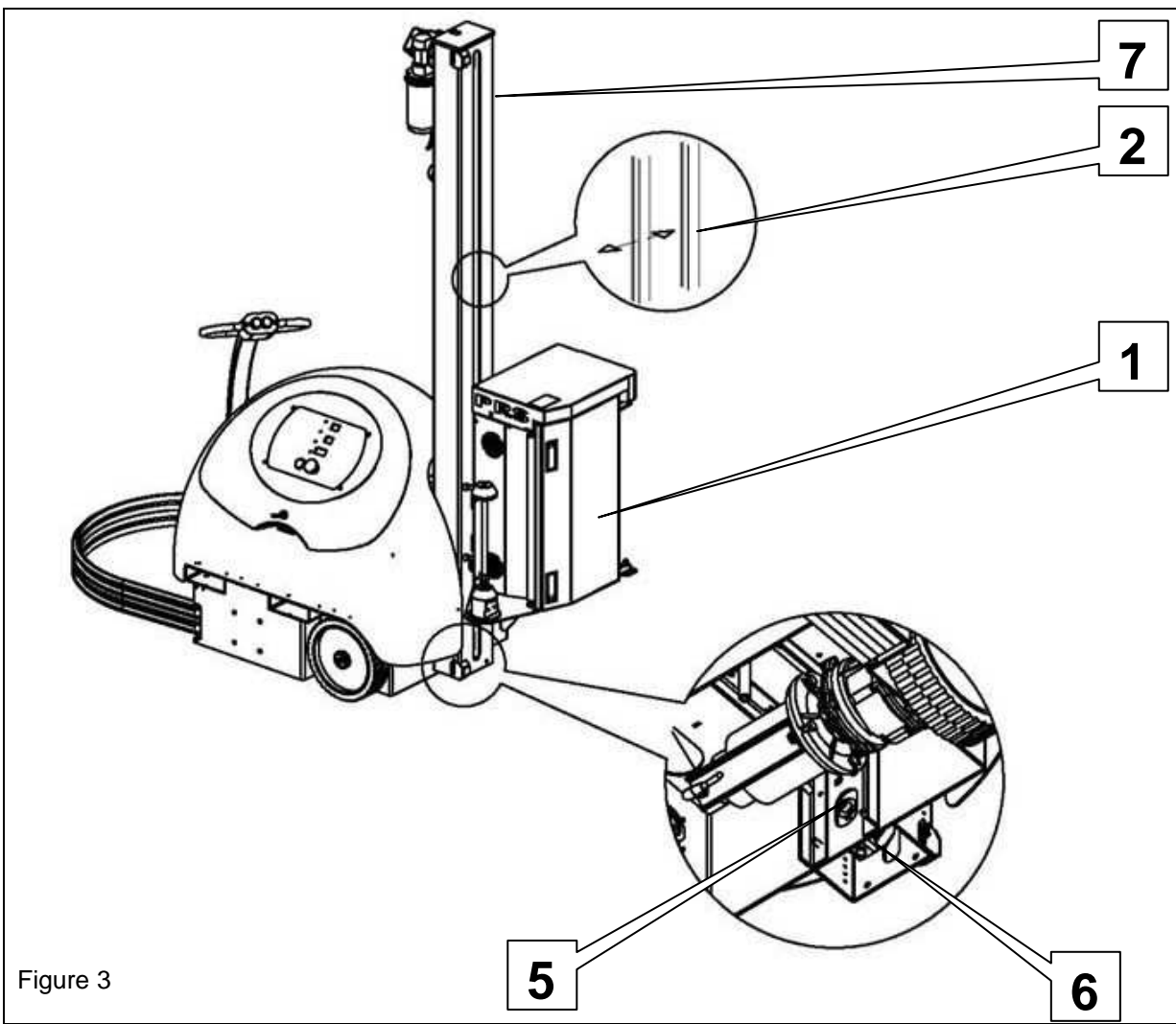

Figure 3

MAINTENANCE INSTRUCTIONS

MAINTENANCE INSTRUCTIONS FOR OPERATORS



Turn off the machine and check the play of the roll-holder carriage. (Fig 3)

If the carriage (1) can be freely lifted with a few centimetres, the chain (2) must be tensioned in the following way.

- Loosen the screw (5), as showed in figure 3 & 4, tighten the screw (6) until the oscillation of the slow branch, measured at the half height of the column (7), is contained in 2 cm. Tighten the screw (5).
- Lubricate the chain with grease.

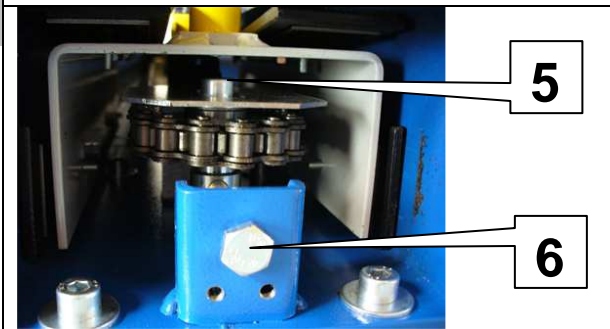

MAINTENANCE SCHEME

MAINTENANCE FREQUENCY							
	8 hr	40 hr	100 hr	200 hr	500 hr	1000 hr	2000 hr
Daily cleaning	X						
Cleaning eye of photocell			X				
Shaft chain				4			
Bearings						X	
Friction discs						X	
Proximity and limit switches						X	
Electrical system							X
Sliding wheels							X
Support wheels							X

The numbers in the maintenance scheme refer to lubricants, which are to be applied in the table with lubricants (hereunder).

The symbol "X" in the maintenance scheme refers to remarks concerning the maintenance of or checking on the relevant part or system.

LUBRICANTS

No.	LUBRICANT					
	SHELL	BP	ESSO	MOBIL OIL	TEXACO	
1	OMALA 220	ENERGOL GR-XP 220	SPARTAN EP 220	MOBILGEAR 630	MEROPA 220	
2	OMALA 680	ENERGOL GR-XP 680	SPARTAN EP 680	MOBILGEAR 636	MEROPA 680	
3	TONNA T68	MACCURAT 68	FEBIS K 68 EP220	VACTA.4	WAX LUBRICANT X68	
4	ALVANIA R	ENERGREASE L2	BEACON 2	MOBILUX 2	MULTIFAK EP2	
5	TELLUS 46	HPL 46	NUTCO H46	DTE 26	RANDO HD46	
6	TORCULA 32	ENERGOL RD-E 80	AROX EP 56	ALMOBIL 1	ARIES 32	
7	TELLUS 15				RANDO HDZ 15	
8	RETINAX WB				STARPLEX PREMIUM 1 (depending on the application)	