

FROMM

Numbers & Drawings Art. code : FS3.2796

**Stretch Wrapping machine's
FS390 Top-Sheet**

**Version 01 Machines
Version 01 List**

Website : www.fromm-stretch.com

Maintenance / Control advices:

- A = Clean**
- B = Check fixation / Tighten**
- C = Check wearing / Condition / Inspection**
- D = Grease / Lubrification**
- E = Control functionality / Parameters / Settings**

- 4200 - Replacement parts (nuts, screws, etc.)**
- 4215 - Client labels**
- 4400 - Advised spareparts**
- 4401 - Wearing parts**
- 4402 - Construction parts**
- 4403 - Electrical components**
- 4404 - Pneumatic components**
- 4405 - Machine labels**
- 4410 - Assembled groups**

TOP-SHETT_FS7.0181B.V01.EN01/ © 07/15

Instruction Top-sheet dispenser FS7.0181 for FS390 machine

Details Top-sheet:

English

Internal film core: Ø76 mm

Height core: Height core with holes already done (need enlarge) on the mast to have exactly H=1500mm.
However It is possible to have different height cores but need to drill the mast to fix the top bracket in a different position.

Diameter film: max Ø260mm

Italian

Diametro int. cartone: Ø76mm

Altezza bobina film: Altezza bobina con prefori già presenti sulla colonna in modo da avere la posizione precisa H=1500mm (fori comunque da ripassare allargandoli)
Sono possibili altre altezze di bobine a seconda delle necessità del cliente ma occorre fare i fori sulla colonna.

Diametro esterno film: max Ø260 mm

FOR FIXING THE TOP SHEET DISPENSER NEED TO MAKE HOLES Ø4,5 ON THE MAST
IN THE CORRECT POSITION AND SCREW THE SCREWS N1.7339

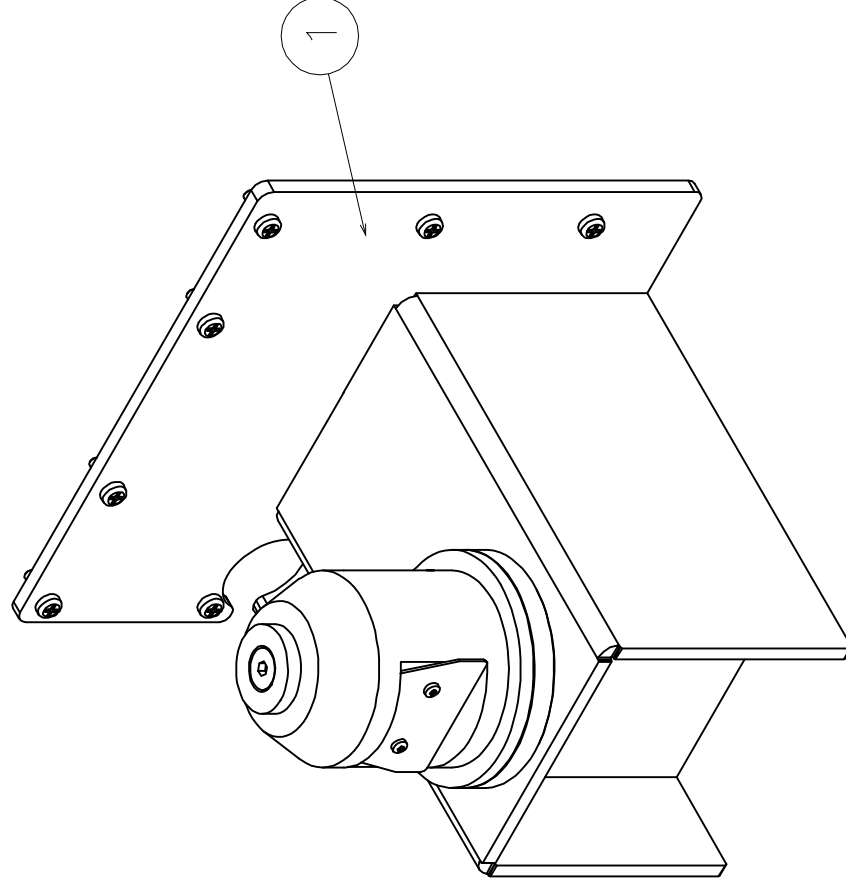
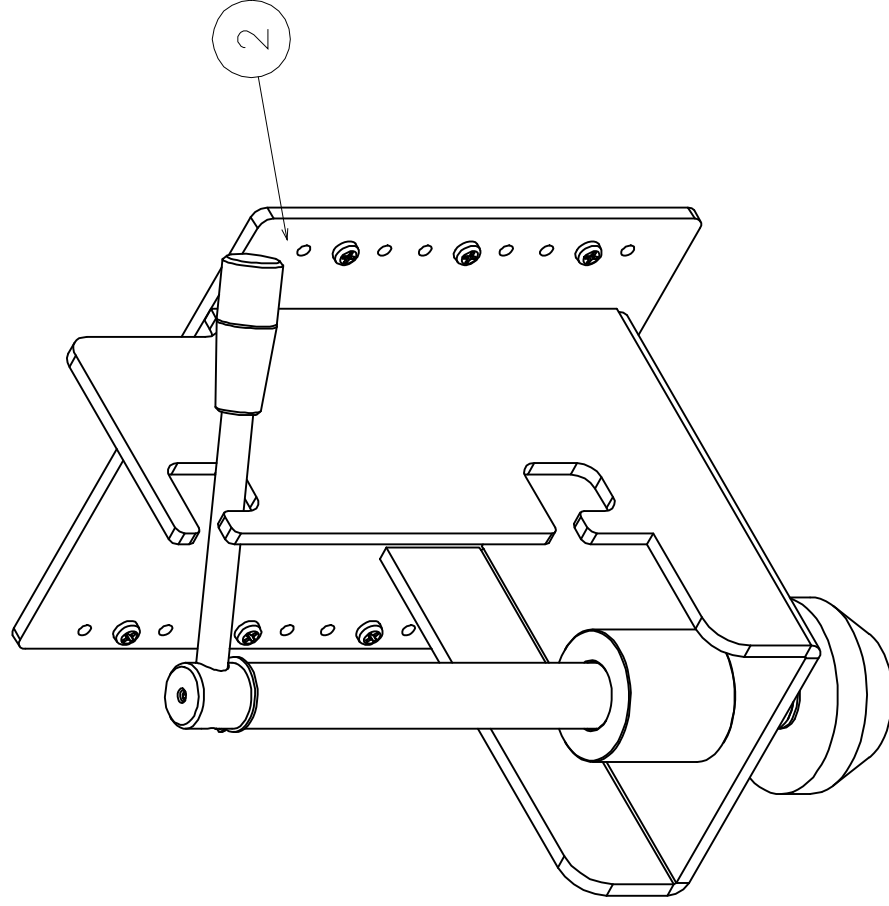

FS7.0181B Group TOP-SHEET Dispenser

Part no.	RIF	Description	Specification English	Q.ty	Maintenance	Art. Group
FS7.0176B	1	Group	GROUP LOWER TOP-SHEET	1	A-E	4410
FS7.0178B	2	Group	GROUP UPPER TOP-SHEET	1	A-E	4410

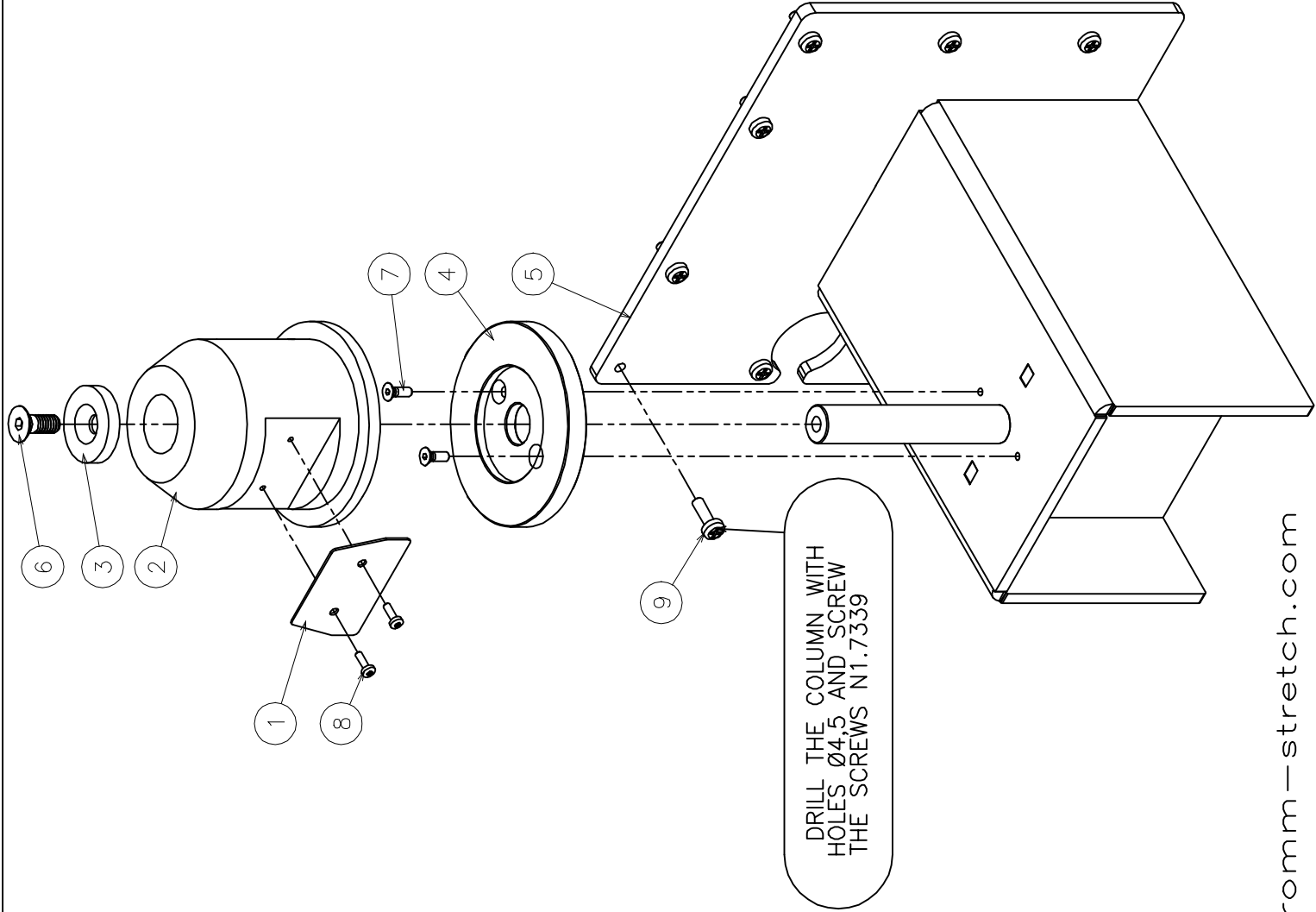

DRILL THE COLUMN WITH HOLES Ø4.5 AND SCREW THE SCREWS N1.7339

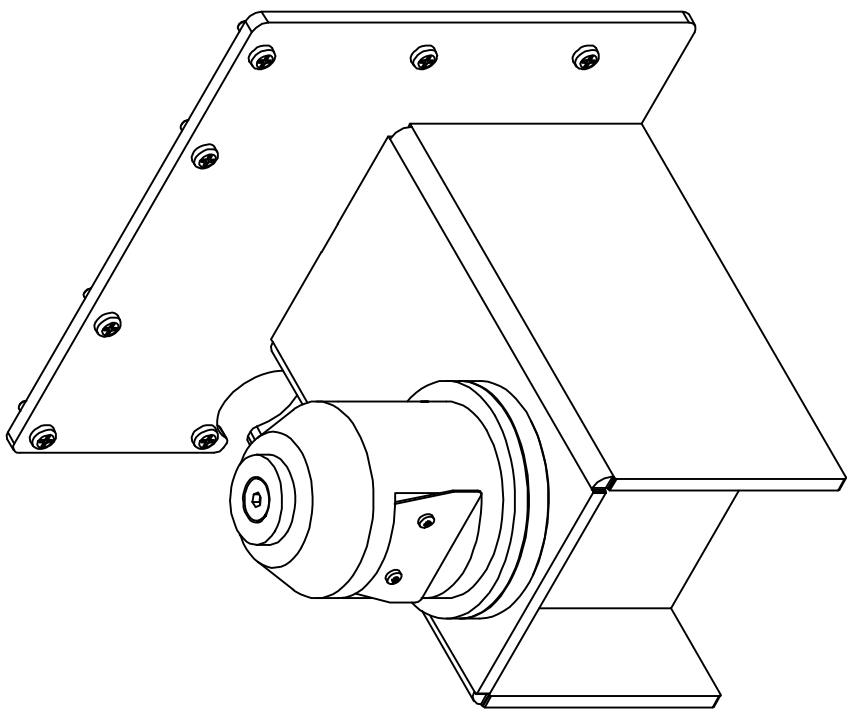

FS7.0176B Group lower TOP-SHEET

Part no.	RIF	Description	Specification English	Q.ty	Maintenance	Art. Group
FS3.2039	1	Bracket	HARMONIC STEEL PLATE SPOOL HOLDER LOCKER	1	A-C	4402
FS3.2184	2	Holder	SPOOL HOLDER	1	A-C	4400
FS3.2389Z	3	Washer	WASHER	1		4402
FS3.2776	4	Disk	DISK	1	A	4401
FS7.1658B	5	Bracket	LOWER BRACKET	1	A	4402
N1.2147	6	Screw	HEXAGON SOCKET COUNTERSUNK HEAD CAP M8x20	1	B	4200
N1.2180	7	Bolt	HEXAGON SOCKET COUNTERSUNK HEAD CAP M4x12	2		4200
N1.7336	8	Bolt	CYLINDRICAL HEAD SCREW UNI 9707 - M3.5 x 10	2	B	4200
N1.7339	9	Bolt	BUTTON HEAD SCREW UNI 8112 =10 K=3.85 C15	8		4200

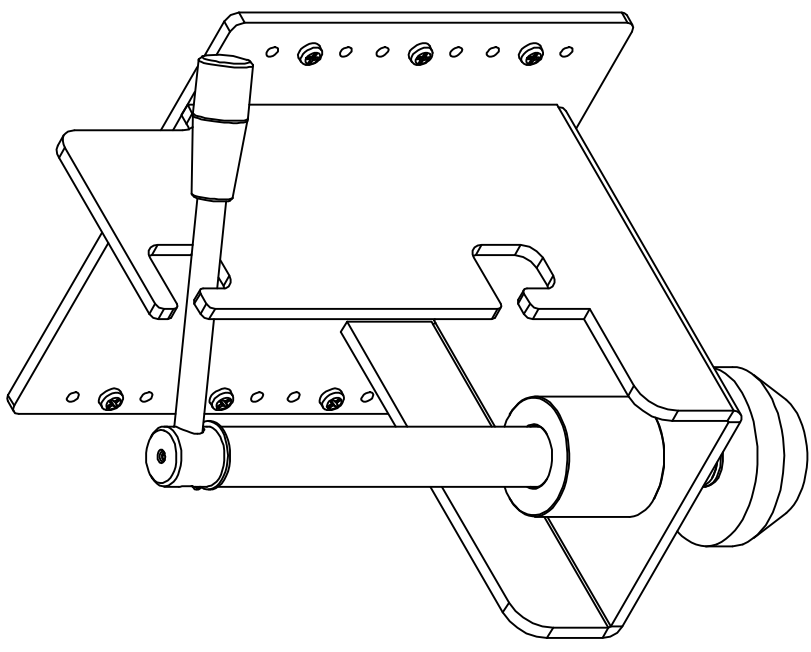

DRILL THE COLUMN WITH HOLES Ø4.5 AND SCREW THE SCREWS N°1.7339

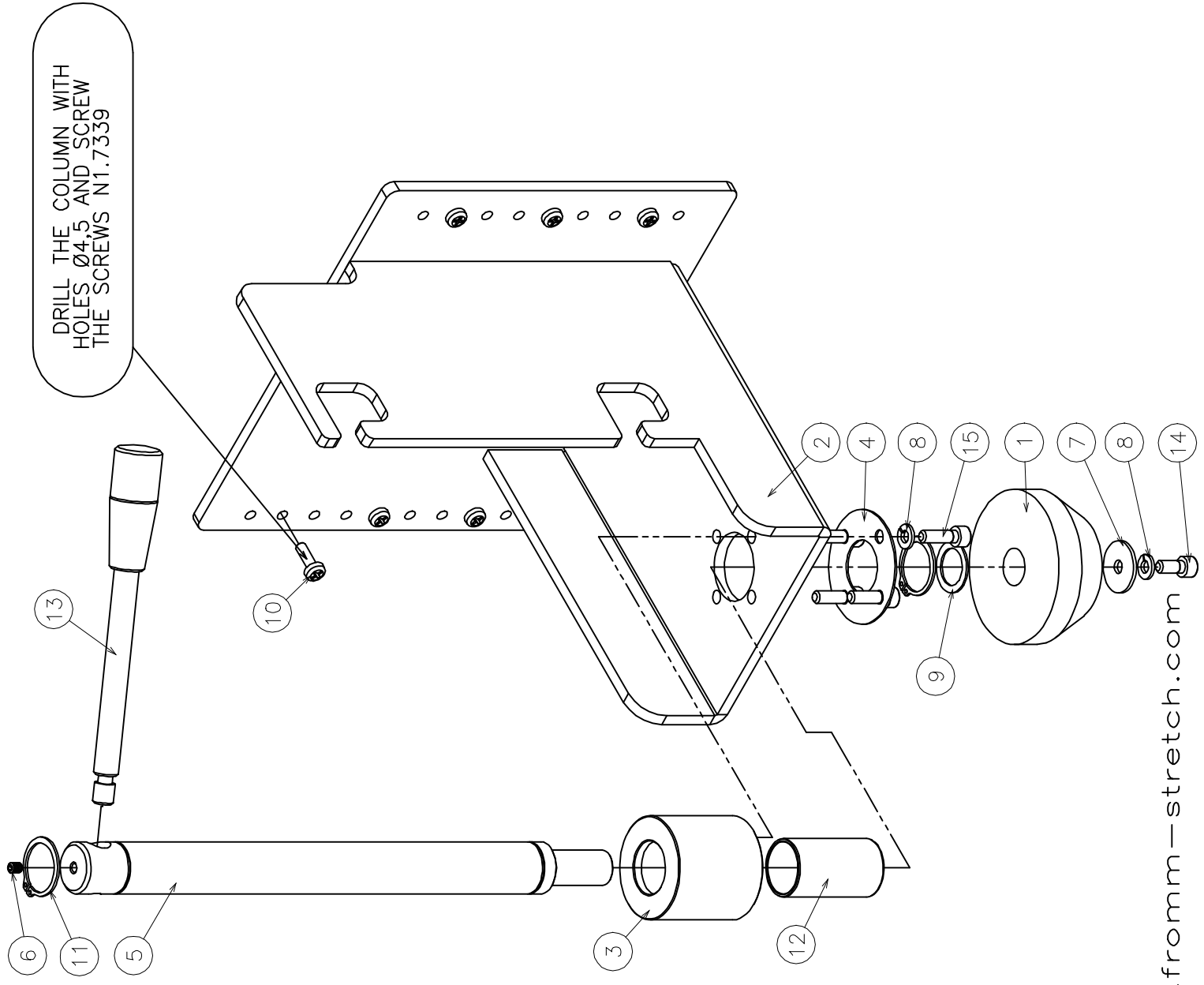

FS7.0178B Group upper TOP-SHEET

Part no.	RIF	Description	Specification English	Q.ty	Maintenance	Art. Group
FS3.2231	1	Holder	SPOOL HOLDER CENTRAL	1	A-C	4400
FS7.1670B	2	Bracket	UPPER BRACKET	1	A	4402
FS7.1671	3	Flange	FLANGE	1		4402
FS7.1672B	4	Plate	PLATE	1		4402
FS7.1673	5	Shaft	SHAFT	1	E	4402
N1.3302	6	Bolt	BOLT M5 X6 BLACK DIN 916	1	B	4200
N1.6175	7	Washer	PLAIN WASHER 6,4X25X1,8 (7X25)	1		4200
N1.6204	8	Washer	SPRING LOCK WASHER DIN 127 -B- UNI1751/52A M6 ZN	5		4200
N1.6325	9	Washer	SPECIAL WASHER DIN 988 TYPE "PS" 18x25x1	1		4200
N1.7339	10	Bolt	BUTTON HEAD SCREW UNI 8112 =10 K=3.85 C15	6		4200
N2.1105	11	Seeger	SEEGER FOR SHAFT D.25 TYPE A DIN 471	2		4200
N3.3184	12	Bush	BUSH 25x28x50	1		4200
N4.1941	13	Lever	LEVER d.12xD.17 - M10 L=174	1	B	4200
N11.1136	14	Screw	CYLINDRICAL HEAD SCREW CL.8.8 DIN 912 M6x14 ZN	1		4200
N11.1143	15	Screw	CYLINDRICAL HEAD SCREW CL.8.8 DIN 912 M6x20 ZN	4		4200

