

FROMM

Numbers & Drawings Art. code : FS4.2008

**Stretch Wrapping machine's
FS15x OP2-AWP**

**Version 01 Machines
Version 02 List**

Website : www.fromm-stretch.com

Maintenance / Control advices:

- A = Clean**
- B = Check fixation / Tighten**
- C = Check wearing / Condition / Inspection**
- D = Grease / Lubrification**
- E = Control functionality / Parameters / Settings**

- 4200 - Replacement parts (nuts, screws, etc.)**
- 4215 - Client labels**
- 4400 - Advised spareparts**
- 4401 - Wearing parts**
- 4402 - Construction parts**
- 4403 - Electrical components**
- 4404 - Pneumatic components**
- 4405 - Machine labels**
- 4410 - Assembled groups**

SPARE-PARTS_FS15x.V01.EN02/a.servisi/ © 05/17

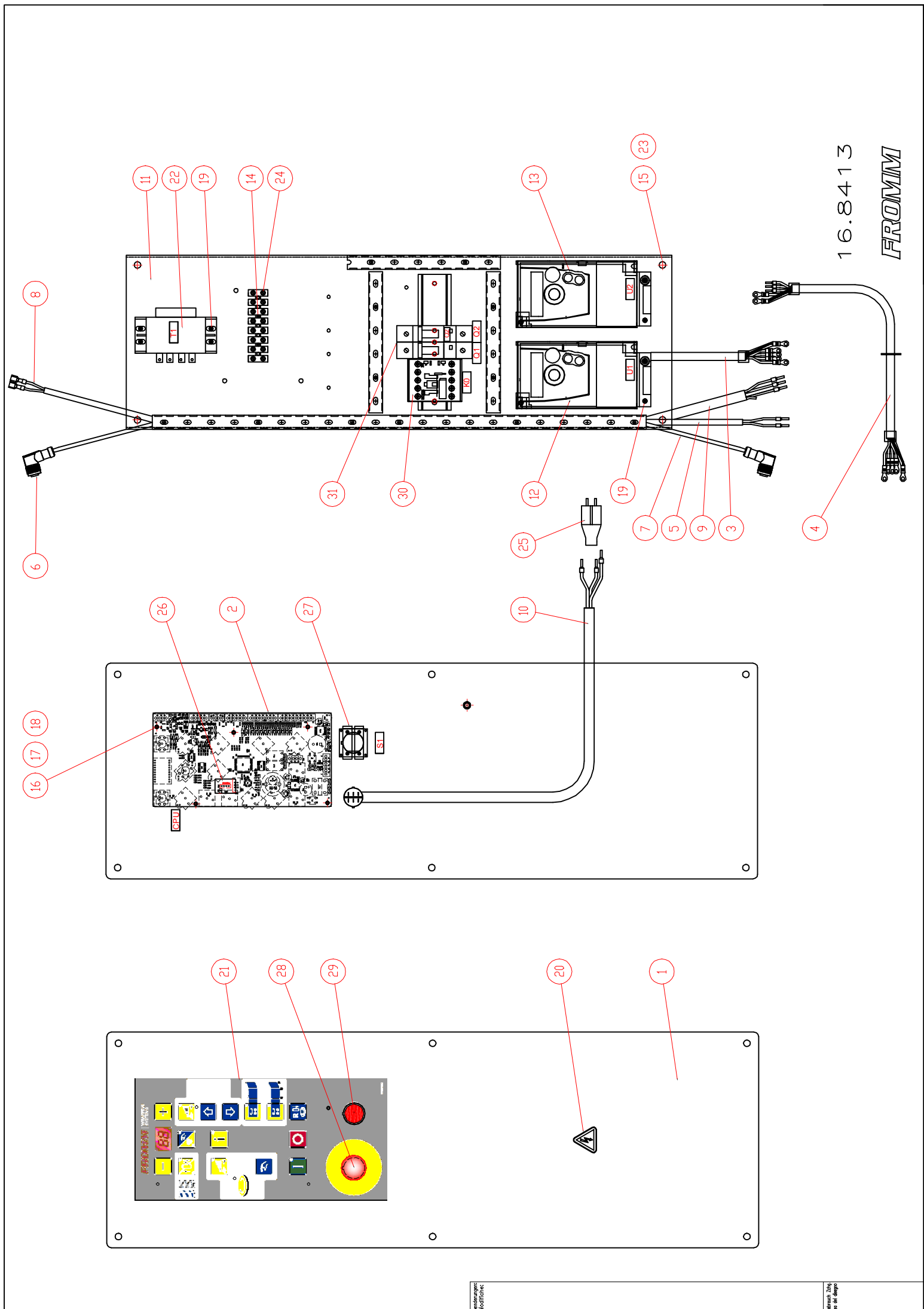

16.8413

FROMM

16.8413 Operating Panel AWP FS1.0211-013.1013

Part no.	RIF	Description	Specification English	Q.ty	Maintenance	Art. group
FS1.2074	1	Panel	MAST CLOSING OP2	1	A	4402
FS1.2079	2	Panel	PROTECTION PANEL FOR PC-BOARD	1		4402
FS1.2100	3	Cable	CABLE FOR MOTOR TURNTABLE	1		4403
FS1.2101	4	Cable	CABLE FOR MOTOR CARRIAGE	1		4403
FS1.2102	5	Cable	CABLE FOR BOTTOM MICROSWITCH	1		4403
FS1.2103	6	Cable	CABLE FOR TOP PROXIMITY	1		4403
FS1.2104	7	Cable	TURNTABLE PROXIMITY CABLE	1		4403
FS1.2105	8	Cable	CABLE FOR MICRO	1		4403
FS1.2106	9	Cable	4-WIRE CABLE CARRIAGE FS1xx	1		4403
FS1.2107	10	Cable	POWER SUPPLY CABLE	1	C	4403
FS3.2026	11	Plate	ELECTRICAL COMPONENT PLATE	1		4402
FS3.2450	12	Inverter	INVERTER TABLE (OP2)	1	E	4403
FS3.2452	13	Inverter	INVERTER CARRIAGE (OP2)	1	E	4403
N1.1714	14	Screw	CYLINDRICAL HEAD CAP SCREW 2.9x16 ZN DIN 7981	2	B	4200
N1.1918	15	Screw	PHILIPS HEAD SCREW M4x12 ZINCED DIN 7985	2	B	4200
N1.1932	16	Screw	PHILIPS HEAD SCREW M3x8 ZINCED DIN 7985	5	B	4200
N1.5313	17	Nut	NUT M3 DIN 985 ZINCED	5		4200
N1.5942	18	Distance	HEXAGONAL DISTANCE PIECE	5		4200
N1.7333	19	Screw	HEAD PIN SCREW M4x10 ZINCED UNI 8112	8	B	4200
N4.9192	20	Label	TENSION LABEL 51mm	1	A-C	4405
N43.9160	21	Label	LABEL PANEL BUDGET PLUS (OP2)	1	A-C	4401
N5.1463	22	Transfor.	TRANSFORMATOR	1	E	4403
N5.3811	23	Distance	DISTANCE PIECE M4	2		4200
N5.6701	24	Clamp	CLAMP 12 POLES 1.5MM	0.6	B	4403
N51.2120	25	Plug	PLUG 10/16A	1	B-C	4403
FS3.2731	26	Panel	OPERATING PANEL OP2-AWP	1	E	4403
N52.2251	27	Contact	AUXILIARY CONTACT	2	E	4403
N52.2252	28	Emer.-stop	EMERGENCY-STOP MUSHROOM	1	E	4403
N52.2270	29	Switch on/off	SWITCH ON/OFF	1	E	4403
N52.5217	30	Contacto	POWER CONTACTOR	1	E	4401
N52.5218	31	Switch	THERMAL OVERCURRENT CIRCUIT BREAKERS	2	E	4403

LOCTITE 243

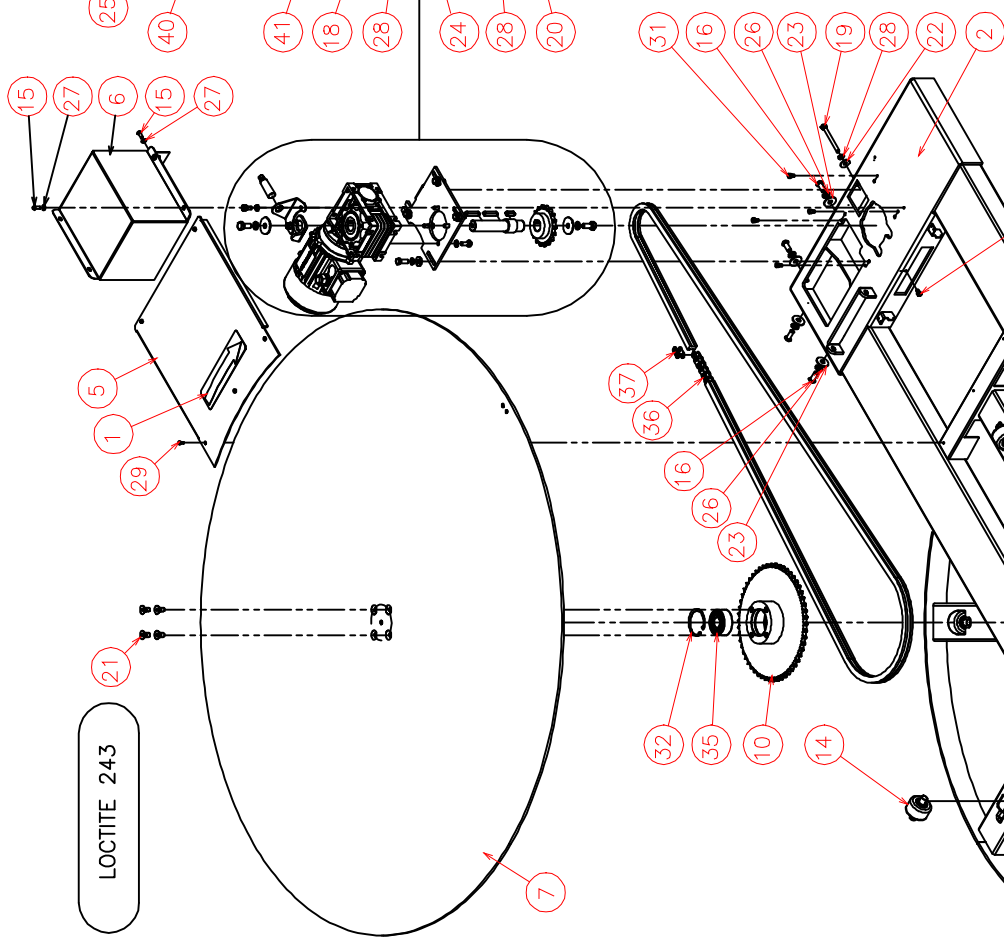
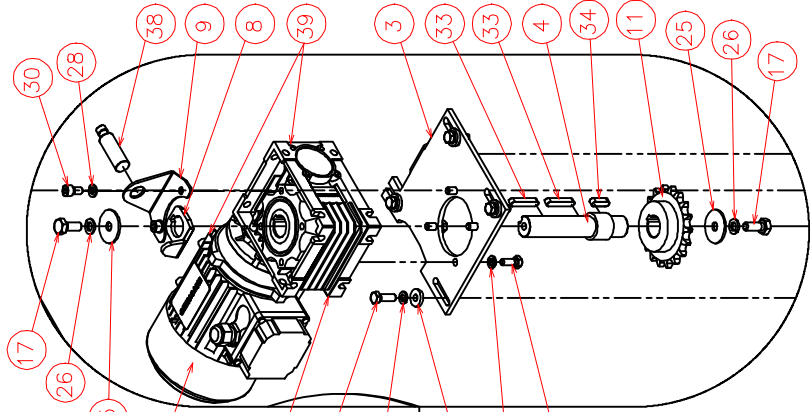

NO ROLLS IN THIS POSITION

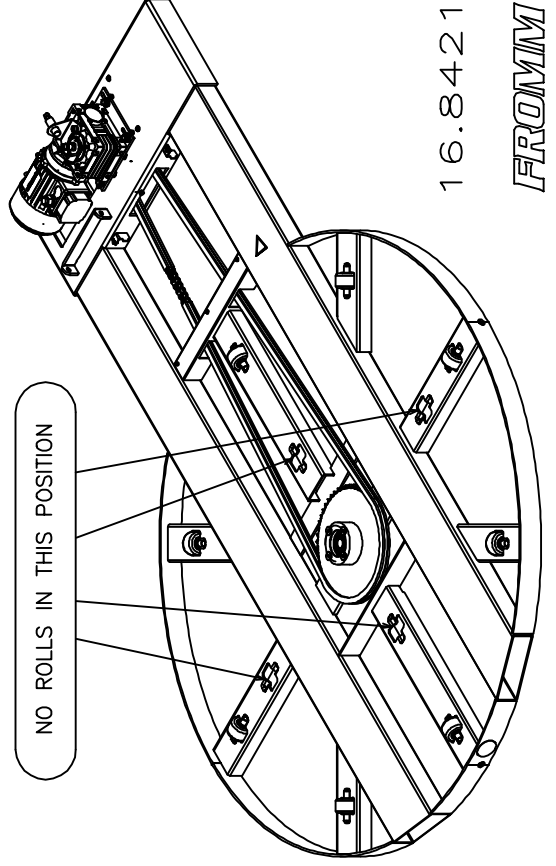

16.8421

FROMM

www.fromm-stretch.com

Verwendete
Schrauben
von
FROMM

Verwendete
Schrauben
von
FROMM

16.8421 Base unit FS1.0201GB Ø1500mm

Part no.	RIF	Description	Specification English	Q.ty	Maintenance	Art. Group
FS1.1379	1	Label	LABEL WITH DRAWING OF ARROW	1	C	4405
FS1.2000B	2	Base unit	PAINTED BASE UNIT DIAMETER 1500 BLUE RAL 5010	1	A	4402
FS1.2009Z	3	Support	SUPPORT FOR GEARBOX	1		4402
FS1.2011	4	Shaft	SHAFT	1	C	4400
FS1.2020B	5	Cover	PAINTED CLOSING BASE BLUE RAL 5010	1	A	4402
FS1.2026B	6	Carter	PAINTED MOTOR CARTER BLUE RAL 5010	1	A-C	4402
FS3.2083G	7	Disk	PAINTED DISK D.1500 YELLOW RAL 1021	1	A-C	4402
FS3.2088	8	Bracket	BRACKET SHAFT BASE UNIT	1		4402
FS3.2089	9	Bracket	BRACKET SUPPORT SENSOR BASE UNIT	1		4402
FS3.2099	10	Gear	GEAR 5/8"x3/8" Z=54	1		4200
FS3.2103	11	Pinion	PINION 5/8"x3/8" Z=18	1		4200
FS3.2342	12	Label	FALL DANGER LABEL	1	A-C	4405
FS3.2344	13	Label	FORKLIFT TRUCK LABEL	1	A-C	4405
FS4.1017	14	Roller	ROLL (VALID UNTIL 31.12.2011)	8	A-C-D	4401
FS4.0168	14	Roller	ROLL (VALID FROM 01.01.2012)	8	A-C-D	4401
N1.1220	15	Screw	BUTTON HEAD SCREW ISO 7380 - M6 x 16	4		4200
N1.1228	16	Bolt	BUTTON HEAD BOLT M10x25 ZINCED UNI 7380	4	B	4200
N1.1546	17	Bolt	HEXAGONAL HEAD CAP BOLT M10x25 ZN DIN 933	2	B	4200
N1.1557	18	Bolt	HEXAGONAL HEAD CAP BOLT M8x25 ZN DIN 933	4	B	4200
N1.1588	19	Bolt	HEXAGONAL HEAD CAP BOLT M8x80 ZN DIN 933	1	B	4200
N1.1589	20	Bolt	HEXAGONAL HEAD CAP BOLT M8x18 ZN DIN 933	4	B	4200
N1.2183	21	Bolt	SOCKET CTRS. HD BOLT DIN 7991-A- M10 x 20	4	B	4200
N1.6109	22	Washer	WASHER D.24x 8,4x2 ZN DIN 9021/B	1		4200
N1.6130	23	Washer	WASHER D.10.5X30X2.5 ZN DIN 9021/B	4		4200
N1.6138	24	Washer	WASHER D.8.4X21X4 ZN DIN 7349	4		4200
N1.6196	25	Washer	PLAIN WASHER UNI 6593 M10 TYPE A 10.5x40x2.5	2		4200
N1.6201	26	Washer	SPRING LOCK WASHER DIN 127 -B- M10 ZN	6		4200
N1.6204	27	Washer	SPRING LOCK WASHER DIN 127 -B- M6 ZN	4		4200
N1.6215	28	Washer	SPRING LOCK WASHER DIN 127 -B- M8 ZN	11		4200
N1.7333	29	Screw	HEAD PIN SCREW DIN 7500-C M4x10 ZN	5		4200
N11.1102	30	Bolt	CYLINDRICAL HEAD BOLT CL.8.8 DIN 912 M8x16 ZN	2		4200
N11.1121	31	Bolt	CYLINDRICAL HEAD BOLT CL.8.8 DIN 912 M6x10 ZN	5		4200
N2.1223	32	Seeger	SEEGER D.62 TYPE "J" UNI 3654/7437	1		4400
N2.3308	33	Key	KEY 8x7x40 UNI 6604	2		4200
N2.3314	34	Key	KEY 8x7x25 UNI 6604	1		4200
N31.1143	35	Ball bearing	BALL BEARING 62305 2RS1 25x62x24	1	C	4200
N4.7367	36	Chain	CHAIN 5/8"X3/8" 203 LINKS	1	B-D	4200
N4.7415	37	Link	LINK 5/8"X3/8"	1		4200
N5.2554	38	Proximity	PROXIMITY M18 PNP NO CON. M12 (E=distance 2mm)	1	A-E	4403
GROUP MOTORGear FS11x (VALID FROM SERIAL NUMBER MACHINE 03.00005)						
N51.1129	39	Motor/Gear	MOTOR + GEAR	1	B-C-D	4401
N51.1131	40	Motor	MOTOR SIMOTOP MS713-4 POWER 0,55 KW	1	B-C	4403
N4.7655	41	Gear	GEAR CMRV 50-40 71B14 PAM71B14	1	B-C-D	4401

16.8421 Base unit FS1.0201GB Ø1500mm

Part no.	RIF	Description	Specification English	Q.ty	Maintenance	Art. Group
GROUP MOTORGear FS13x (VALID FROM SERIAL NUMBER MACHINE 02.00010)						
N51.1129	39	Motor/Gear	MOTOR + GEAR	1	B-C-D	4401
N51.1131	40	Motor	MOTOR SIMOTOP MS713-4 POWER 0,55 KW	1	B-C	4403
N4.7655	41	Gear	GEAR CMRV 50-40 71B14 PAM71B14	1	B-C-D	4401

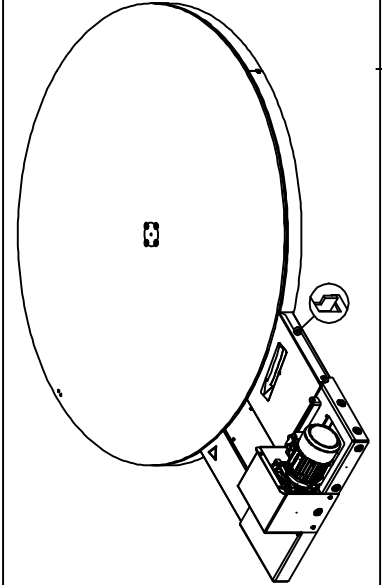

Check the correct position of the spring before and after mounted the safety cover
the safety cover must move freely in the slot

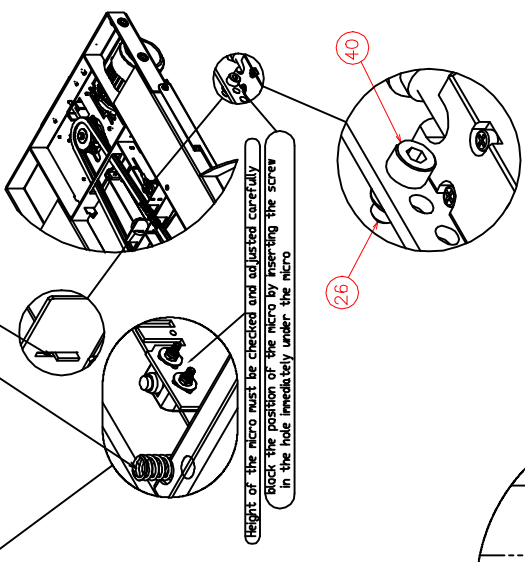

Height of the micro must be checked and adjusted carefully
check the position of the micro by inserting the screw in the hole immediately under the micro

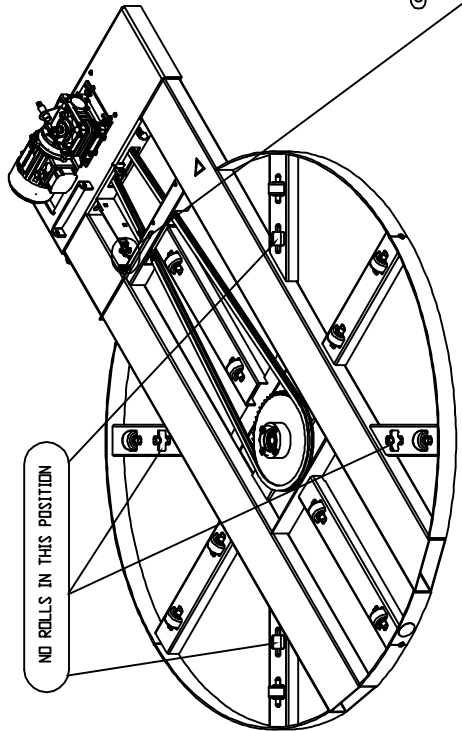

NO ROLLS IN THIS POSITION

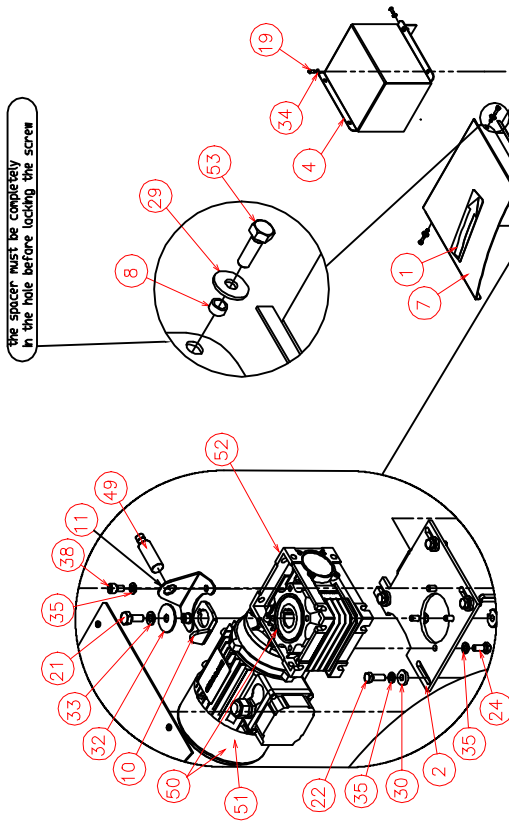

The spacer must be completely in the hole before locking the screw

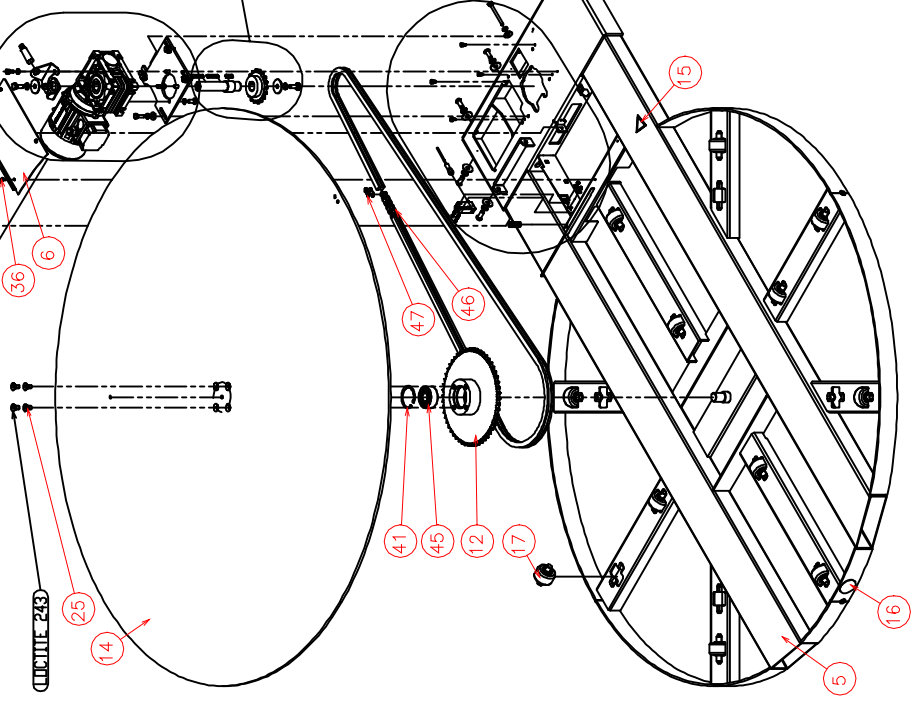
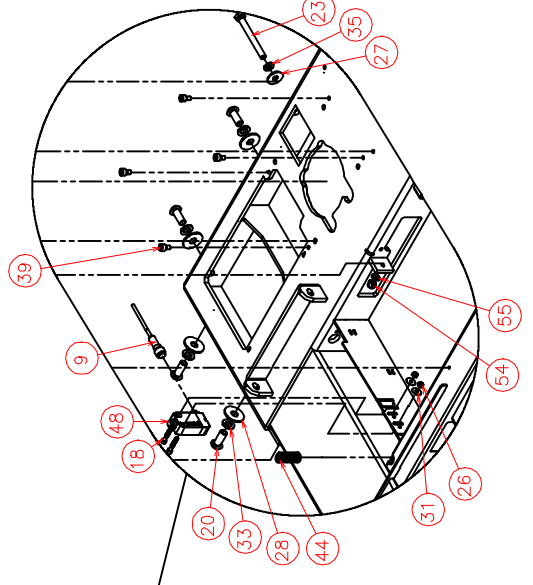
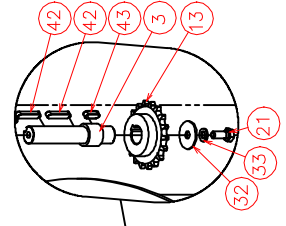

16.8422

FROMM

www.fromm-stretch.com

Reservierung
patentrechtlich

16.8422 Base unit FS1.0207GB Ø1650mm

Part no.	RIF	Description	Specification English	Q.ty	Maintenance	Art. group
FS1.1379	1	Label	LABEL WITH DRAWING OF ARROW	1	C	4405
FS1.2009Z	2	Support	SUPPORT FOR GEARBOX	1		4402
FS1.2011	3	Shaft	SHAFT	1	C	4400
FS1.2026B	4	Carter	PAINTED MOTOR CARTER BLUE RAL 5010	1	A-C	4402
FS1.2080B	5	Group	PAINTED BASE UNIT D.1650MM BLUE RAL 5010	1	A	4402
FS1.2089B	6	Carter	CARTER FOR THE CHAIN	1	A	4402
FS1.2094G	7	Carter	CARTER	1	A	4402
FS1.2096	8	Distan. piece	DISTANCE PIECE	2		4200
FS1.2119	9	Cable	MICROSWITCH CABLE	1		4403
FS3.2088	10	Bracket	BRACKET SHAFT BASE UNIT	1		4402
FS3.2089	11	Bracket	BRACKET SUPPORT SENSOR BASE UNIT	1		4402
FS3.2099	12	Gear	GEAR 5/8"x3/8" Z=54	1	D	4200
FS3.2103	13	Pinion	PINION 5/8"x3/8" Z=18	1	D	4200
FS3.2144G	14	Disk	PAINTED DISK D.1650 YELLOW RAL 1021	1	A-C	4402
FS3.2342	15	Label	FALL DANGER LABEL	1	E	4405
FS3.2344	16	Label	FORKLIFT TRUCK LABEL	1	E	4405
FS4.1017	17	Roller	ROLL (VALID UNTIL 31.12.2011)	12	A-C-D	4401
FS4.0168	17	Roller	ROLL (VALID FROM 01.01.2012)	12	A-C-D	4401
N1.1191	18	Screw	CYLINDRICAL HEAD CAP SCREW DIN 912 M4x25 BL.	2		4200
N1.1220	19	Screw	BUTTON HEAD SCREW ISO 7380 - M6 x 16	4		4200
N1.1228	20	Bolt	BUTTON HEAD BOLT M10x25 ZINCED UNI 7380	4	B	4200
N1.1546	21	Bolt	HEXAGONAL HEAD CAP BOLT M10x25 ZN DIN 933	2	B	4200
N1.1557	22	Bolt	HEXAGONAL HEAD CAP BOLT M8x25 ZN DIN 933	4	B	4200
N1.1588	23	Bolt	HEXAGONAL HEAD CAP BOLT M8x80 ZN DIN 933	1	B	4200
N1.1589	24	Bolt	HEXAGONAL HEAD CAP BOLT M8x18 ZN DIN 933	4	B	4200
N1.2183	25	Bolt	SOCKET CTRS. HD BOLT DIN 7991-A- M10 x 20	4	B	4200
N1.5307	26	Nut	PREVAILING HEXAGON TORQUE / NON MET. INS. M4	3		4200
N1.6109	27	Washer	WASHER D.24x 8,4x2 ZN DIN 9021/B	1		4200
N1.6130	28	Washer	WASHER D.10.5X30X2.5 ZN DIN 9021/B	4		4200
N1.6131	29	Washer	PLAIN WASHER M6 6,4x18x1,6 DIN 9021B GAL.	2		4200
N1.6138	30	Washer	WASHER D.8.4X21X4 ZN DIN 7349	4		4200
N1.6160	31	Washer	PLAIN WASHER M4 4,3x14x0,8 GALVANIZED	2		4200
N1.6196	32	Washer	PLAIN WASHER UNI 6593 M10 TYPE A 10.5x40x2.5	2		4200
N1.6201	33	Washer	SPRING LOCK WASHER DIN 127 -B- M10 ZN	6		4200
N1.6204	34	Washer	SPRING LOCK WASHER DIN 127 -B- M6 ZN	4		4200
N1.6215	35	Washer	SPRING LOCK WASHER DIN 127 -B- M8 ZN	11		4200
N1.7333	36	Screw	HEAD PIN SCREW DIN 7500-C M4x10 ZN	3		4200
N1.7341	37	Screw	HEAD PIN SCREW DIN 7500-C M6x20 ZN	1		4200
N11.1102	38	Bolt	CYLINDRICAL HEAD BOLT CL.8.8 DIN 912 M8x16 ZN	2		4200
N11.1121	39	Bolt	CYLINDRICAL HEAD BOLT CL.8.8 DIN 912 M6x10 ZN	4		4200
N11.1162	40	Screw	CYLINDRICAL HEAD SCREW DIN 912 M4x10 GAL.	1		4200
N2.1223	41	Seeger	SEEGER D.62 TYPE "J" UNI 3654/7437	1		4400
N2.3308	42	Key	KEY 8x7x40 UNI 6604	2		4200
N2.3314	43	Key	KEY 8x7x25 UNI 6604	1		4200
N2.5231	44	Spring	SPRING	1		4200

16.8422 Base unit FS1.0207GB Ø1650mm

Part no.	RIF	Description	Specification English	Q.ty	Maintenance	Art. group
N31.1143	45	Ball bearing	BALL BEARING 62305 2RS1 25x62x24	1	C	4200
N4.7368	46	Chain	CHAIN 5/8"X3/8" 193 LINKS	1		4200
N4.7415	47	Link	LINK 5/8"X3/8"	1		4200
N5.2377	48	Micro	MICRO PIZZATO NF G020AA-DMK	1	C	4403
N5.2554	49	Proximity	PROXIMITY M18 PNP NO CON. M12 (E=distance 2mm)	1	A-E	4403
GROUP MOTORGear FS11x (VALID FROM SERIAL NUMBER MACHINE 03.00005)						
N51.1129	50	Motor/Gear	MOTOR + GEAR	1	B-C-D	4401
N51.1131	51	Motor	MOTOR SIMOTOP MS713-4 POWER 0,55 KW	1	B-C	4403
N4.7655	52	Gear	GEAR CMRV 50-40 71B14 PAM71B14	1	B-C-D	4401
GROUP MOTORGear FS13x (VALID FROM SERIAL NUMBER MACHINE 02.00010)						
N51.1129	50	Motor/Gear	MOTOR + GEAR	1	B-C-D	4401
N51.1131	51	Motor	MOTOR SIMOTOP MS713-4 POWER 0,55 KW	1	B-C	4403
N4.7655	52	Gear	GEAR CMRV 50-40 71B14 PAM71B14	1	B-C-D	4401
N1.1523	53	Screw	HEXAGON HEAD SCREW DIN 9339 M6x25 GAL.	1		4200
N1.5301	54	Nut	NUT M6 DIN 985 SHORT GALVANIZED	1		4200
N1.6163	55	Washer	PLAIN WASHER DIN 125A M6 6,4x12x1,6 GAL.	1		4200

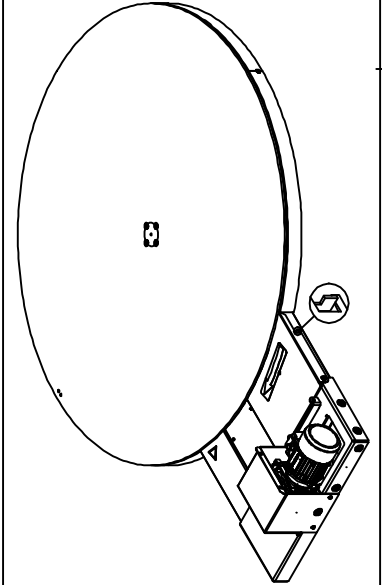

Check the correct position of the spring before and after mounting the safety cover
the safety cover must move freely in the slot

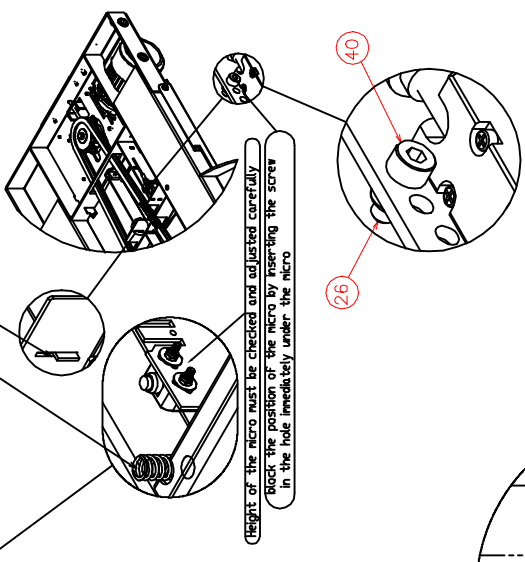

Height of the micro must be checked and adjusted carefully
check the position of the micro by inserting the screw
in the hole immediately under the micro

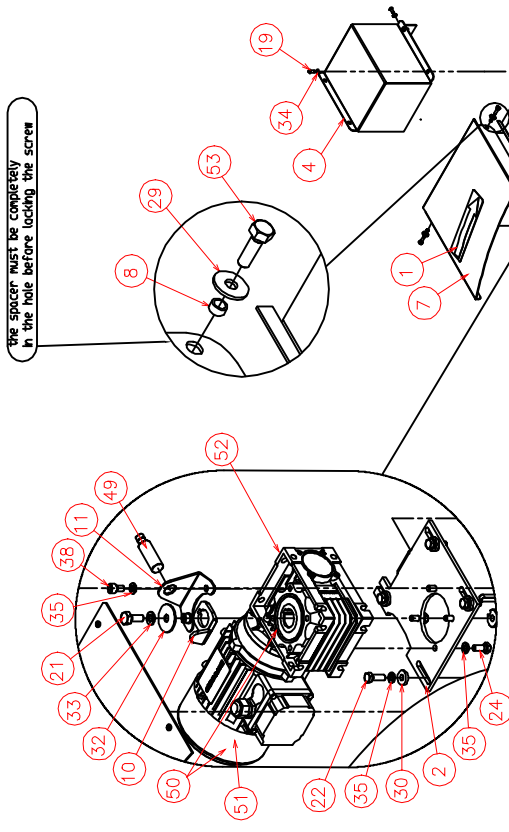
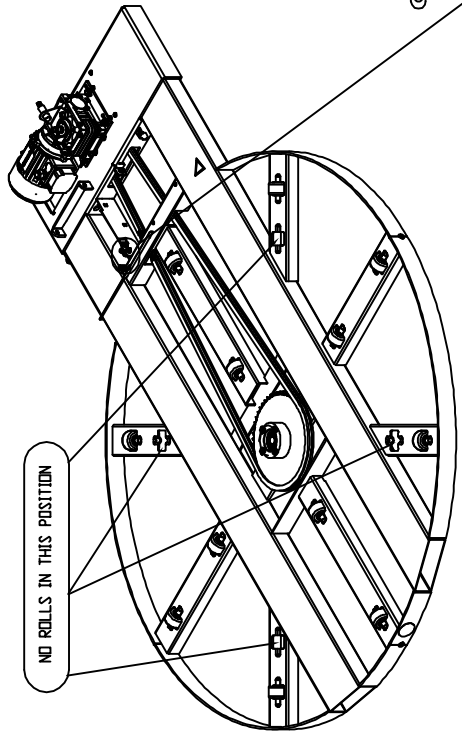

The spacer must be completely
in the hole before locking the screw

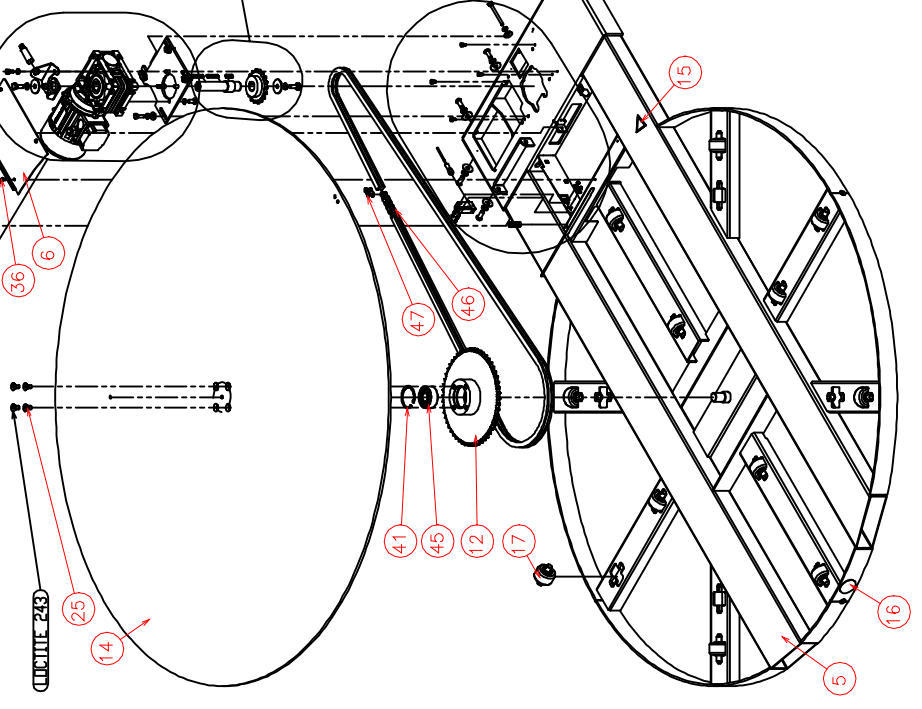
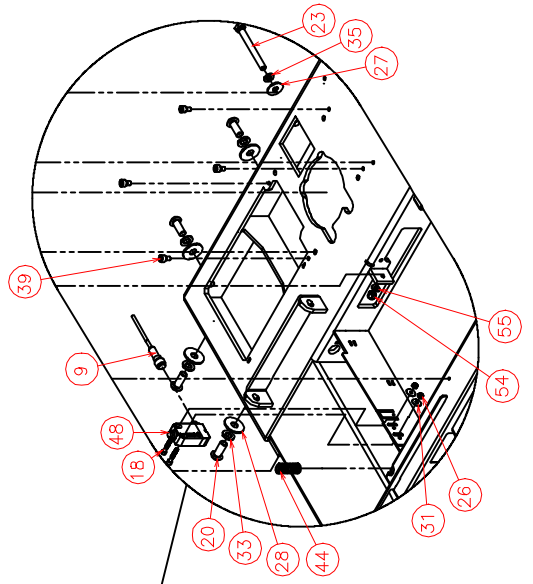
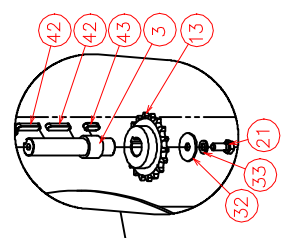

Reparaturanleitung
Accessories

16.8423

FROMM

www.fromm-stretch.com

16.8423 Base unit FS1.0207GB Ø1650mm (2000kg)

Part no.	RIF	Description	Specification English	Q.ty	Maintenance	Art. group
FS1.1379	1	Label	LABEL WITH DRAWING OF ARROW	1	C	4405
FS1.2009Z	2	Support	SUPPORT FOR GEARBOX	1		4402
FS1.2011	3	Shaft	SHAFT	1	C	4400
FS1.2026B	4	Carter	PAINTED MOTOR CARTER BLUE RAL 5010	1	A-C	4402
FS1.2080B	5	Group	PAINTED BASE UNIT D.1650MM BLUE RAL 5010	1	A	4402
FS1.2089B	6	Carter	CARTER FOR THE CHAIN	1	A	4402
FS1.2094G	7	Carter	CARTER	1	A	4402
FS1.2096	8	Distan. piece	DISTANCE PIECE	2		4200
FS1.2119	9	Cable	MICROSWITCH CABLE	1		4403
FS3.2088	10	Bracket	BRACKET SHAFT BASE UNIT	1		4402
FS3.2089	11	Bracket	BRACKET SUPPORT SENSOR BASE UNIT	1		4402
FS3.2099	12	Gear	GEAR 5/8"x3/8" Z=54	1	D	4200
FS3.2103	13	Pinion	PINION 5/8"x3/8" Z=18	1	D	4200
FS3.2144G	14	Disk	PAINTED DISK D.1650 YELLOW RAL 1021	1	A-C	4402
FS3.2342	15	Label	FALL DANGER LABEL	1	E	4405
FS3.2344	16	Label	FORKLIFT TRUCK LABEL	1	E	4405
FS4.1017	17	Roller	ROLL (VALID UNTIL 31.12.2011)	16	A-C-D	4401
FS4.0168	17	Roller	ROLL (VALID FROM 01.01.2012)	16	A-C-D	4401
N1.1191	18	Screw	CYLINDRICAL HEAD CAP SCREW DIN 912 M4x25 BL.	2		4200
N1.1220	19	Screw	BUTTON HEAD SCREW ISO 7380 - M6 x 16	4		4200
N1.1228	20	Bolt	BUTTON HEAD BOLT M10x25 ZINCED UNI 7380	4	B	4200
N1.1546	21	Bolt	HEXAGONAL HEAD CAP BOLT M10x25 ZN DIN 933	2	B	4200
N1.1557	22	Bolt	HEXAGONAL HEAD CAP BOLT M8x25 ZN DIN 933	4	B	4200
N1.1588	23	Bolt	HEXAGONAL HEAD CAP BOLT M8x80 ZN DIN 933	1	B	4200
N1.1589	24	Bolt	HEXAGONAL HEAD CAP BOLT M8x18 ZN DIN 933	4	B	4200
N1.2183	25	Bolt	SOCKET CTRS. HD BOLT DIN 7991-A- M10 x 20	4	B	4200
N1.5307	26	Nut	PREVAILING HEXAGON TORQUE / NON MET. INS. M4	3		4200
N1.6109	27	Washer	WASHER D.24x 8,4x2 ZN DIN 9021/B	1		4200
N1.6130	28	Washer	WASHER D.10.5X30X2.5 ZN DIN 9021/B	4		4200
N1.6131	29	Washer	PLAIN WASHER M6 6,4x18x1,6 DIN 9021B GAL.	2		4200
N1.6138	30	Washer	WASHER D.8.4X21X4 ZN DIN 7349	4		4200
N1.6160	31	Washer	PLAIN WASHER M4 4,3x14x0,8 GALVANIZED	2		4200
N1.6196	32	Washer	PLAIN WASHER UNI 6593 M10 TYPE A 10.5x40x2.5	2		4200
N1.6201	33	Washer	SPRING LOCK WASHER DIN 127 -B- M10 ZN	6		4200
N1.6204	34	Washer	SPRING LOCK WASHER DIN 127 -B- M6 ZN	4		4200
N1.6215	35	Washer	SPRING LOCK WASHER DIN 127 -B- M8 ZN	11		4200
N1.7333	36	Screw	HEAD PIN SCREW DIN 7500-C M4x10 ZN	3		4200
N1.7341	37	Screw	HEAD PIN SCREW DIN 7500-C M6x20 ZN	1		4200
N11.1102	38	Bolt	CYLINDRICAL HEAD BOLT CL.8.8 DIN 912 M8x16 ZN	2		4200
N11.1121	39	Bolt	CYLINDRICAL HEAD BOLT CL.8.8 DIN 912 M6x10 ZN	4		4200
N11.1162	40	Screw	CYLINDRICAL HEAD SCREW DIN 912 M4x10 GAL.	1		4200
N2.1223	41	Seeger	SEEGER D.62 TYPE "J" UNI 3654/7437	1		4400
N2.3308	42	Key	KEY 8x7x40 UNI 6604	2		4200
N2.3314	43	Key	KEY 8x7x25 UNI 6604	1		4200
N2.5231	44	Spring	SPRING	1		4200

16.8423 Base unit FS1.0207GB Ø1650mm (2000kg)

Part no.	RIF	Description	Specification English	Q.ty	Maintenance	Art. group
N31.1143	45	Ball bearing	BALL BEARING 62305 2RS1 25x62x24	1	C	4200
N4.7368	46	Chain	CHAIN 5/8"X3/8" 193 LINKS	1		4200
N4.7415	47	Link	LINK 5/8"X3/8"	1		4200
N5.2377	48	Micro	MICRO PIZZATO NF G020AA-DMK	1	C	4403
N5.2554	49	Proximity	PROXIMITY M18 PNP NO CON. M12 (E=distance 2mm)	1	A-E	4403
GROUP MOTORGear FS11x (VALID FROM SERIAL NUMBER MACHINE 03.00005)						
N51.1129	50	Motor/Gear	MOTOR + GEAR	1	B-C-D	4401
N51.1131	51	Motor	MOTOR SIMOTOP MS713-4 POWER 0,55 KW	1	B-C	4403
N4.7655	52	Gear	GEAR CMRV 50-40 71B14 PAM71B14	1	B-C-D	4401
GROUP MOTORGear FS13x (VALID FROM SERIAL NUMBER MACHINE 02.00010)						
N51.1129	50	Motor/Gear	MOTOR + GEAR	1	B-C-D	4401
N51.1131	51	Motor	MOTOR SIMOTOP MS713-4 POWER 0,55 KW	1	B-C	4403
N4.7655	52	Gear	GEAR CMRV 50-40 71B14 PAM71B14	1	B-C-D	4401
N1.1523	53	Screw	HEXAGON HEAD SCREW DIN 9339 M6x25 GAL.	1		4200
N1.5301	54	Nut	NUT M6 DIN 985 SHORT GALVANIZED	1		4200
N1.6163	55	Washer	PLAIN WASHER DIN 125A M6 6,4x12x1,6 GAL.	1		4200

FS1.0233GB Horseshoe D.1500mm Right/Left side loading

Part no.	RIF	Description	Specification English	Q.ty	Maintenance	Art. Group
FS1.0232G	1	Group	GROUP DISK PAINTED YELLOW RAL1021 L. P. PAIN.	1	A	4410
FS1.0234	2	Group	GROUP MOTORGear HORSESHOE	1	E	4410
FS1.2009	3	Support	SUPPORT	1		4402
FS1.2281	4	Pinion	PINION 1/2"x5/16" Z22	1	C-D	4400
FS1.2282	5	Shaft	SHAFT	1	E-C	4400
N1.1546	6	Bolt	HEXAGONAL HEAD CAP BOLT M10x25 ZN DIN 933	2	B	4200
N1.1589	7	Bolt	HEXAGONAL HEAD CAP BOLT M8x18 ZN DIN 933	4	B	4200
N1.6196	8	Washer	PLAIN WASHER UNI 6593 M10 TYPE A 10.5x40x2.5	2		4200
N1.6215	9	Washer	SPRING LOCK WASHER DIN 127 -B- M8 ZN	4		4200
N1.6216	10	Washer	SPRING LOCK WASHER DIN 127 -B- M10 ZN	2		4200
N2.3314	11	Key	KEY 8x7x25 UNI 6604	1		4200
N2.3355	12	Key	KEY 8x7x35 UNI 6604	2		4200
N1.1557	13	Bolt	HEXAGON HEAD BOLT M8x25 DIN 933 ZINCED	4	B	4200
N1.6138	14	Washer	WASHER D.8.4X21X4 ZN DIN 7349	4		4200
N51.1143	15	Motorgear	MOTORGear CMRV 50-10 71B14 + 713-4 0.55KW	1	B-C-D	4401
N51.1131	16	Motor	MOTOR SIMOTOP MS713-4 POWER 0,55 KW	1	B-C	4403
N4.7663	17	Gear	GEARBOX SIZE 50 - RATIO 1/10 CMRV 50-10 71B14	1	B-C-D	4401
FS1.0235B	18	Group	GROUP PAINTED ENTRY PALLET BLUE RAL 5010	1	A-C-E	4410
FS1.0237B	19	Group	GROUP PLATE BLUE RAL 5010	1	A-C-E	4410
FS3.0226	20	Group	GROUP RUBBERED WHEEL	2	C	4410
N2.1105	21	Seeger	ELASTIC RING TYPE A D.25 DIN 471	1		4200
FS4.1450	22	Wheel	RUBBERED WHEEL	1	C	4401
N31.1141	23	Ball bearing	BALL BEARING 63005 2RS1 25X47X16	2	A-C	4200
FS4.1451	24	Pinion	Pinion 1/2"x5/16" Z=24	1	C-D	4200
N1.2168	25	Bolt	SOCKET CTRS HD BOLT DIN 7991 M8x16 ZINCED	3	B	4200
FS4.1444	26	Lever	LEVER	1		4402
FS1.1379	27	Label	LABEL WITH DRAWING OF ARROW	1	C	4405
FS1.2026B	28	Carter	PAINTED MOTOR CARTER BLUE RAL 5010	1	A-C	4402
FS1.2280B	29	Base	STRUCTURE BASE HORSESHOE BLUE RAL 5010	1	A-C	4402
FS1.2295B	30	Carter	CARTER FOR COVER CABLES BLUE RAL 5010	1	A-C	4402
FS1.2297B	31	Carter	CARTER BLUE RAL 5010	1	A-C	4402
FS1.2298B	32	Bracket	BRACKET BLUE RAL 5010	2	A-C	4402
FS1.2312	33	Photocell	PHOTOCELL + CABLE	1	A-C	4403
FS1.2313	34	Cable	PHOTOCELL MD + CABLE	1	A-C	4403
FS3.2342	35	Label	FALL DANGER LABEL	2	C	4405

FS1.0233GB Horseshoe D.1500mm Right/Left side loading

Part no.	RIF	Description	Specification English	Q.ty	Maintenance	Art. Group
FS3.2343	36	Label	CRUSHING DANGER LABEL	1	C	4405
FS3.2363Z	37	Bracket	PHOTOCELL ZINCED BRACKET	1	E	4402
FS3.2375	38	Spacer	SPACER	3		4200
FS3.2389Z	39	Washer	SPECIAL ZINCED WASHER	1		4200
FS4.1449	40	Spring	POLIURETANIC SPRING D.I.=10.5 L=20	2	C-E	4400
N1.1220	41	Screw	BUTTON HEAD SCREW ISO 7380 - M6 x 16	14		4200
N1.1228	42	Bolt	BUTTON HEAD BOLT M10x25 ZINCED UNI 7380	4		4200
N1.1502	43	Bolt	HEXAGON HEAD BOLT M6x10 DIN 933 ZINCED	2		4200
N1.1546	44	Bolt	HEXAGON HEAD BOLT M10x25 DIN 933 ZINCED	2		4200
N1.1582	46	Bolt	HEXAGON HEAD BOLT M10x75 DIN 933 ZINCED	2		4200
N1.1588	47	Bolt	HEXAGONAL HEAD CAP BOLT M8x80 ZN DIN 933	1		4200
N1.1714	48	Screw	BUTTON HEAD SCREW M2.9x16 DIN 7981 ZINCED	2		4200
N1.2147	49	Bolt	SOCKET CTRS. HD BOLT DIN 7991 M8x20 ZINCED	1		4200
N1.5108	50	Nut	NUT M10 DIN 934 ZINCED	2		4200
N1.6109	51	Washer	WASHER D.24x 8,4x2 ZN DIN 9021/B	1		4200
N1.6130	52	Washer	WASHER D.10.5X30X2.5 ZN DIN 9021/B	4		4200
N1.6167	54	Washer	PLAIN WASHER M5 5.3x10x1 DIN 433 ZINCED	6		4200
N1.6201	55	Washer	SPRING LOCK WASHER DIN 127 -B- M10 ZN	4		4200
N1.6204	56	Washer	SPRING LOCK WASHER DIN 127 -B- M6 ZN	26		4200
N1.6215	57	Washer	SPRING LOCK WASHER DIN 127 -B- M8 ZN	8		4200
N1.6308	58	Washer	SPECIAL WASHER 26x38x0.5	2		4200
N1.7341	59	Screw	HEAD PIN SCREW DIN 7500-C M6x20 ZN	4		4200
N2.1105	60	Seeger	ELASTIC RING TYPE A D.25 DIN 471	2		4400
N4.7238	61	Pinion	PINION WITH BALL BEARINGS 1/2"x5/16" Z=18	3	D	4200
N4.7379	62	Chain	CHAIN 1/2"x5/16" 245 LINKS	1	B-D	4200
N4.7413	63	Link	SPRING CLIP (LINK) 1/2"X5/16" ISO 08B-1	1		4200
N5.6612	64	Box	CONNECTION BOX	1		4403
N5.6701	65	Clamp	CLAMP 12 POLES	1	B	4403
N11.1118	66	Screw	CYLINDRICAL HEAD CAP SCREW M5x10 ZN DIN 912	6		4200
N11.1121	67	Bolt	CYLINDRICAL HEAD BOLT CL.8.8 DIN 912 M6x10 ZN	10		4200
N11.1135	68	Screw	CYLINDRICAL HEAD CAP SCREW M6x12 ZN DIN 912	4		4200
N11.1141	69	Bolt	CYLINDRICAL HEAD CAP SCREW M8x20 ZN DIN 912	3		4200
N11.6105	70	Washer	PLAIN WASHER M6 6.4x24 DIN 7349 ZN	2		4200

OPTION GROUP

FS1.2299	71	Bracket	TRANSPORT BRACKET	1	E	4402
FS1.2301	72	Bracket	TRANSPORT BRACKET	1	E	4402
FS1.2302	73	Bracket	TRANSPORT BRACKET	2	E	4402
FS3.2344	74	Label	FORKLIFT TRUCK LABEL	2	E	4405
N1.1221	75	Screw	BUTTON HEAD SCREW ISO 7380 - M8 x 16	6		4200
N1.6174	76	Washer	PLAIN WASHER M8 8.4x24x2 DIN 9021 ZINCED	22		4200
N11.1102	77	Bolt	CYLINDRICAL HEAD CAP SCREW M8x16 ZN DIN 912	8		4200
N11.1173	78	Bolt	CYLINDRICAL HEAD CAP BOLT M8x25 ZN UNI 5931	8		4200

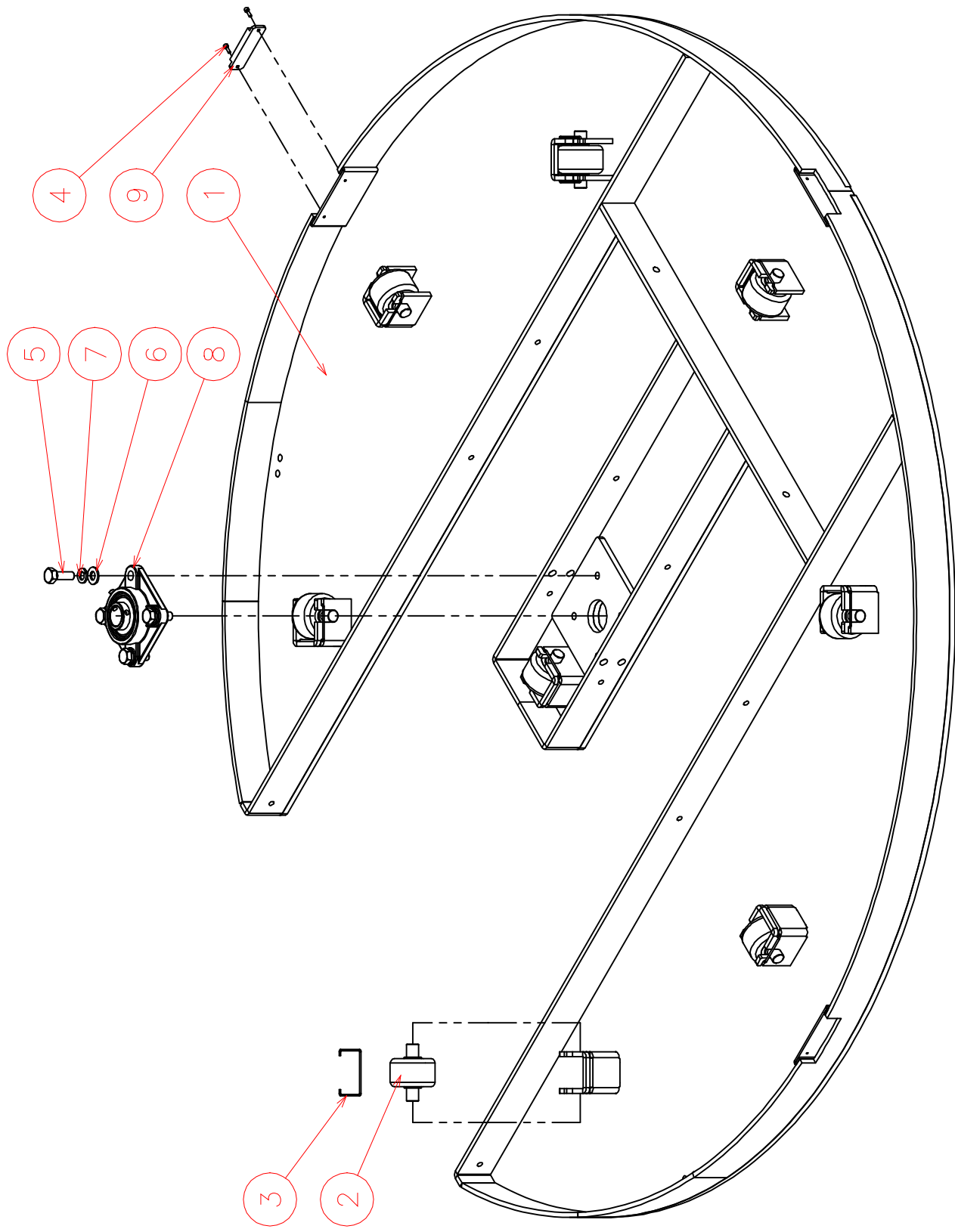

FS1.0232G Group painted disk yellow RAL 1021

Part no.	RIF	Description	Specification English	Q.ty	Maintenance	Art. Group
FS1.2274G	1	Disk	PAINTED DISK D.1475 YELLOW RAL 1021	1	A	4402
FS4.0168	2	Roller	ROLL	8	A-C-D	4401
FS4.1462	3	Wire steel	INOX AISI 302 WIRE STEEL STOP ROLL	8	C-D	4200
N1.1173	4	Screw	CYLINDRICAL HEAD SCREW M3x10 DIN 912 GAL.	2	B	4200
N1.1511	5	Bolt	HEXAGONAL HEAD BOLT M10x30 ZINCED DIN 933	4	B	4200
N1.6161	6	Washer	PLAIN WASHER M10 10,5x20x2 ZINCED DIN 125A	4		4200
N1.6216	7	Washer	SPRING LOCK WASHER M10 DIN 127-B- GALVANIZED	4		4200
N3.4624	8	Support	SWINGING SUPPORT UCF 205	1	C-D	4400
N5.2644	9	Reflector	REFLECTING RL 112-G 19X73 MD	1	A	4400

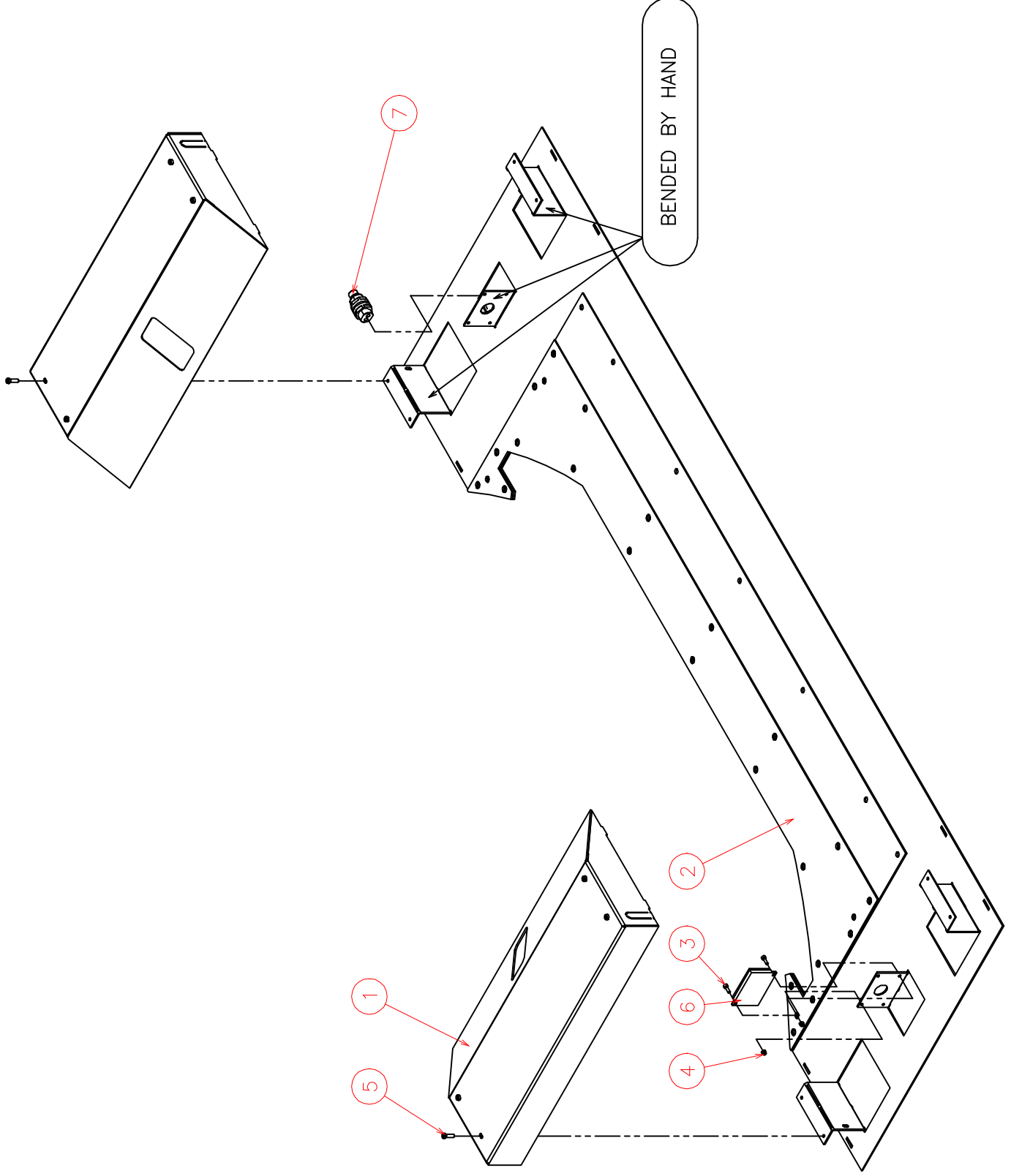

FS1.0235B Group painted entry pallet blue RAL 5010

Part no.	RIF	Description	Specification English	Q.ty	Maintenance	Art. Group
FS1.2304B	1	Carter	CARTER BLUE RAL 5010	2	A-C	4400
FS1.2306B	2	Plate	WELDED PLATE BLUE RAL 5010	1	A-B	4402
N1.1173	3	Screw	CYLINDRICAL HEAD CAP SCREW M3x10 ZN DIN 912	2		4200
N1.5313	4	Nut	NUT M3 DIN 985 ZINCED	2		4200
N1.7334	5	Screw	HEAD PIN SCREW DIN 7500-C M4x14 ZN	8		4200
N5.2645	6	Reflector	REFLECTOR RL116	1	A-B	4400
N5.2698	7	Photocell	PHOTOCELL E3F1-RP21 OMRON	1	A-B-E	4403

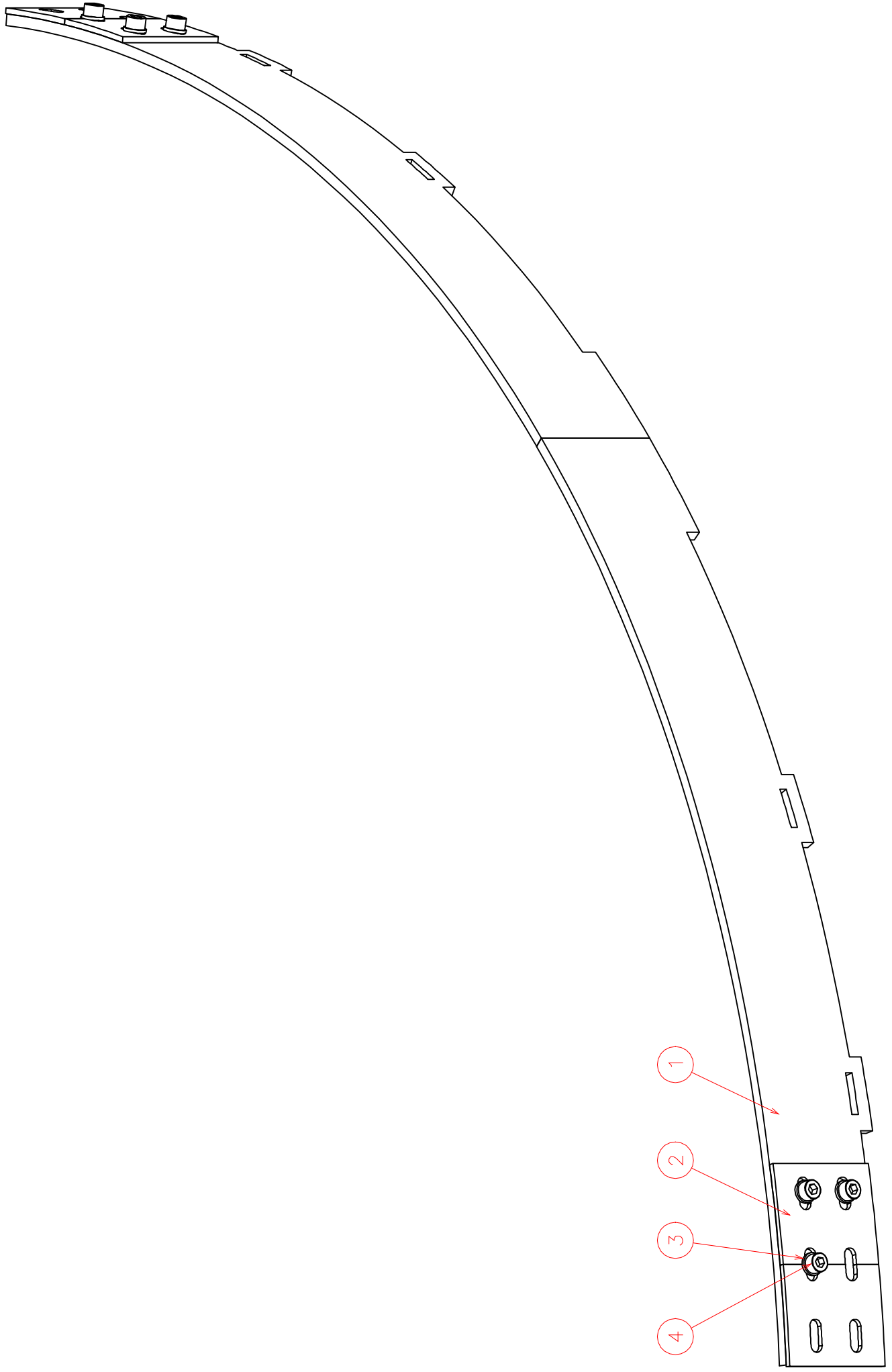

FS1.0237.V01

FROMM

www.fromm-stretch.com

Produktion
Produktionscode

Zeichnung: 2014
Date: 01.08.2014

FS1.0237B Group plate blue RAL 5010

Part no.	RIF	Description	Specification English	Q.ty	Maintenance	Art. Group
FS1.2310B	1	Bracket	PAINTED TABLE ASSEMBLY BRACKET BLUE RAL 5010	1	A-B	4402
FS1.2311B	2	Bracket	PAINTED TABLE ASSEMBLY BRACKET BLUE RAL 5010	2	A-B	4402
N1.6204	3	Washer	SPRING LOCK WASHER DIN 127 -B- M6 ZN	6		4200
N11.1121	4	Bolt	CYLINDRICAL HEAD BOLT CL.8.8 DIN 912 M6x10 ZN	6	B	4200

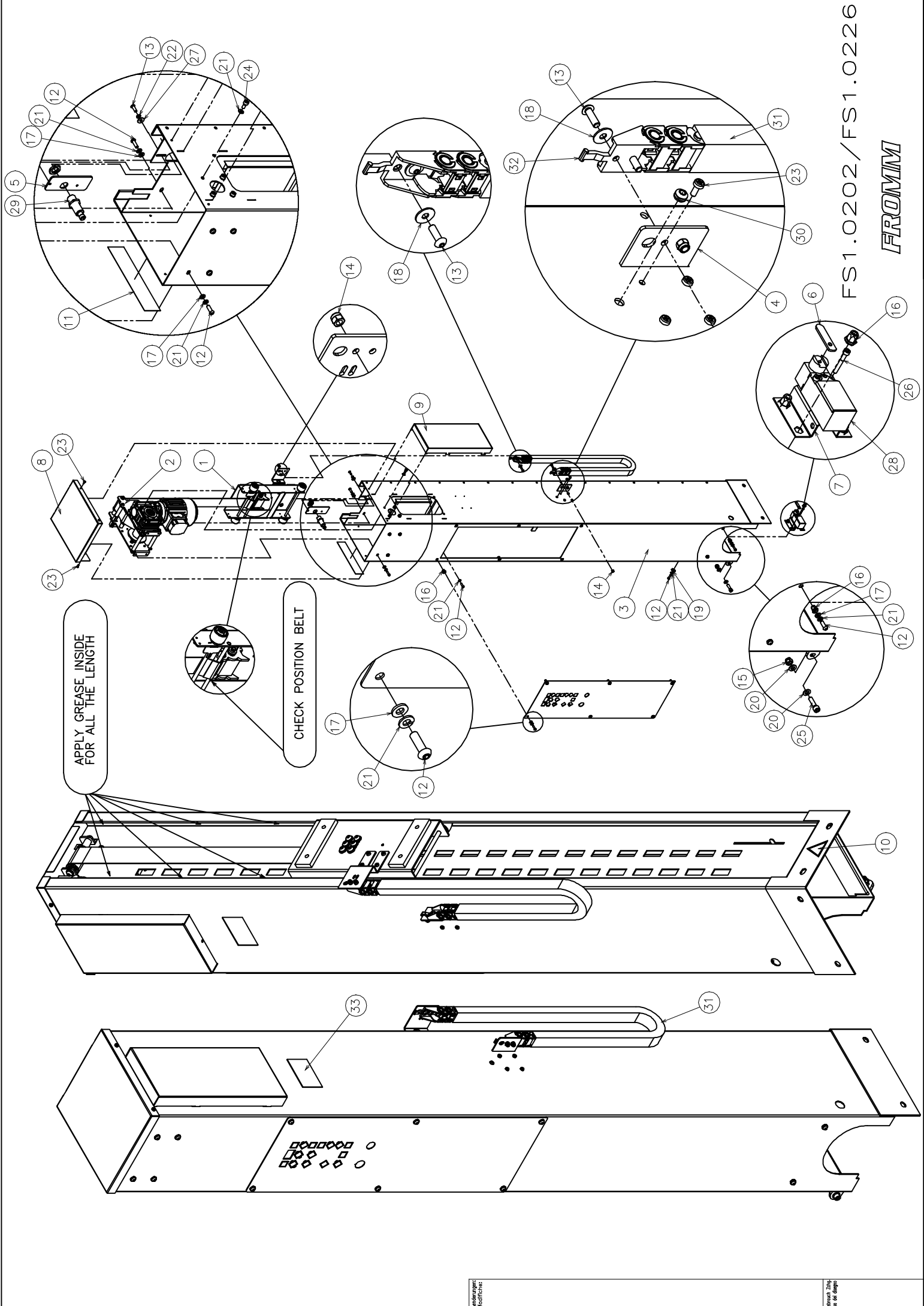

FS1.0202/FS1.0226

FROMM

APPLY GREASE INSIDE FOR ALL THE LENGTH

CHECK POSITION BELT

Mast FS1.0202GB/FS1.0226GB H.2100/2500mm

Part no.	RIF	Description	Specification English	Q.ty	Maintenance	Art. Group
FS1.0204G	1	Group	GROUP CARRIAGE FOR THE MAST YELLOW RAL 1021	1	E	4410
FS1.0205	2	Group	MOTOR/GEAR FOR THE BELT	1	E	4410
FS1.2015B	3	Column	PAINTED COLUMN BLUE RAL 5010 for MAST H.2100mm	1	A-C	4402
FS1.2236B	3	Column	PAINTED COLUMN BLUE RAL 5010 for MAST H.2500mm	1	A-C	4402
FS1.2060B	4	Bracket	BRACKET FOR CABLE CHAIN BLUE RAL 5010	1		4402
FS1.2063Z	5	Bracket	BRACKET PLATE FOR PROXIMITY	1		4402
FS1.2064Z	6	Bracket	BRACKET PLATE FOR MICROSWITCH	1		4402
FS1.2067Z	7	Bracket	BRACKET FOR MICROSWITCH	1		4402
FS1.2070B	8	Carter	TOP CARTER BLUE RAL 5010	1	A	4402
FS1.2071B	9	Carter	MOTOR CARTER BLUE RAL 5010	1	A	4400
FS3.2343	10	Label	CRUSHING DANGER LABEL	1	A-C	4405
FS4.1521	11	Sticker	RED STICKER PVC	1		4405
N1.1222	12	Screw	BUTTON HEAD SCREW ISO 7380 - M6 x 20 ZINCED	21	B	4200
N1.1225	13	Screw	BUTTON HEAD SCREW ISO 7380 - M5 x 16 ZINCED	6	B	4200
N1.5302	14	Nut	NUT DIN 985 M5 ZINCED	4		4200
N1.5305	15	Nut	NUT DIN 985 M14 ZINCED	2		4200
N1.5936	16	Rivet	RIVET HEXAGON HEAD M6 L=16	12		4200
N1.6114	17	Washer	PLAIN WASHER DIN 125A M6 6,4x12x1,6 ZINCED	13		4200
N1.6125	18	Washer	WASHER DIN 9021 M5 5,3X15X1,2 ZINCED	4		4200
N1.6131	19	Washer	PLAIN WASHER DIN 125 - 6,4 x 18 ZINCED	4		4200
N1.6164	20	Washer	PLAIN WASHER DIN 125A M8 8,4x16x1,6 ZN	4		4200
N1.6204	21	Washer	SPRING LOCK WASHER DIN 127 -B- M6	25		4200
N1.6217	22	Washer	SPRING LOCK WASHER DIN 127 -B- M5	1		4200
N1.7333	23	Screw	HEAD PIN SCREW M4x10 ZINCED UNI 8112	8		4200
N11.1136	24	Screw	CYLINDRICAL HEAD CAP SCREW M6x14 ZN DIN 912	4	B	4200
N11.1149	25	Bolt	CYLINDRICAL HEAD CAP BOLT M8x30 ZN DIN 912	2		4200
N11.1174	26	Screw	CYLINDRICAL HEAD CAP SCREW M4x30 ZN DIN 912	2		4200
N11.6104	27	Washer	PLAIN WASHER 15x5.3x1.2 ISO 4759/3 ZN	2		4200
N5.2358	28	Microswitch	MICROSWITCH FR531-A PIZZATO	1	E	4403
N5.2554	29	Proximity	PROXIMITY M18 PNP NO CONN. M12 AK1/AP-1H	1	E	4403
N5.3421	30	Rivet	RUBBER RIVET	1		4200
N5.3768	31	Cable chain	CABLE CHAIN W/SUPPORT 50 LINKS (MAST H.2100mm)	1	C	4400
N5.3771	31	Cable chain	CABLE CHAIN W/SUPPORT 60 LINKS (MAST H.2500mm)	1	C	4400
N5.3769	32	Support	SUPPORT FOR CABLE CHAIN	1	C	4400
FS4.1184	33	Label	LABEL REGISTER FS	1	A-C	4405

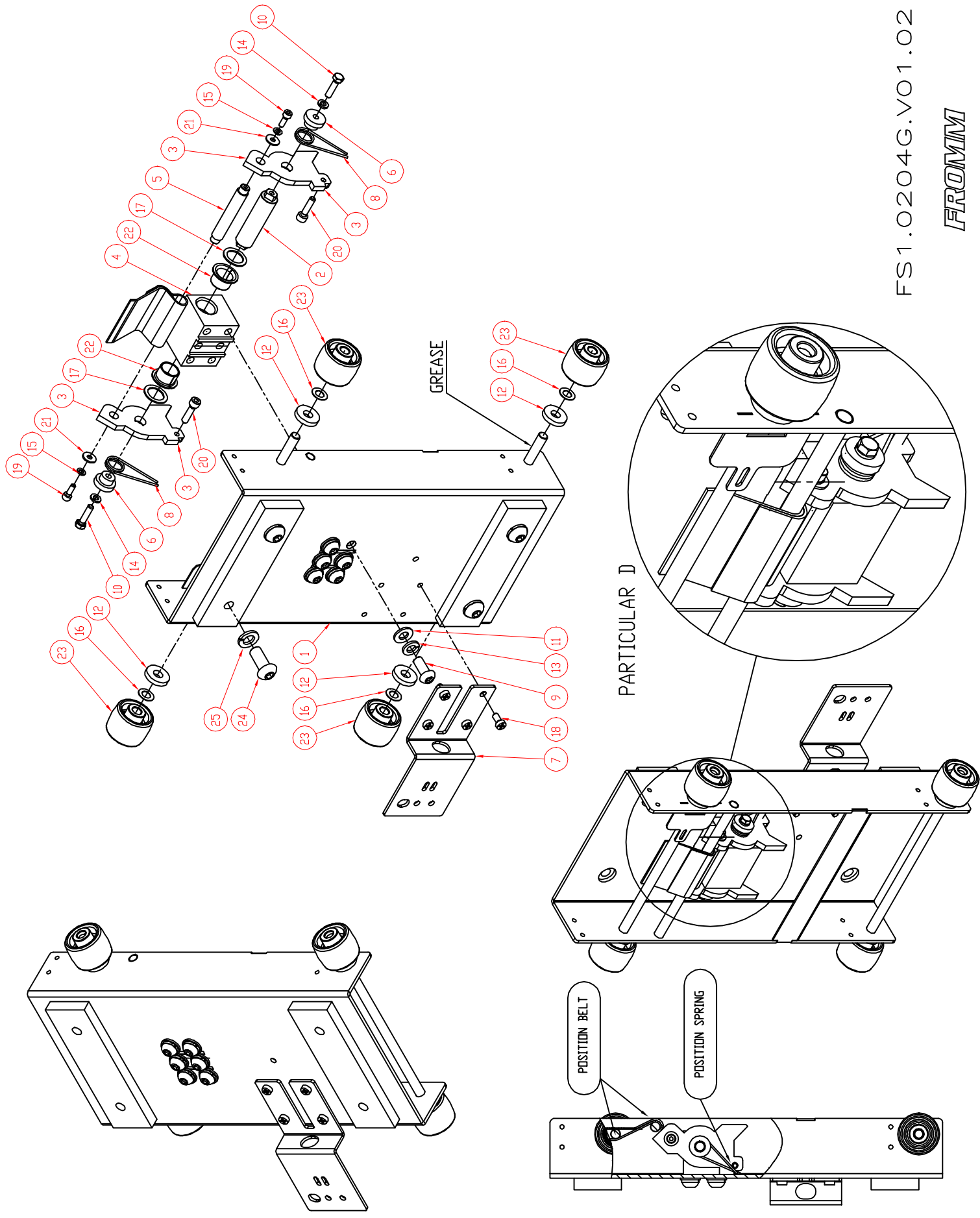

FS1.0204G.V01.02

FROMM

FS1.0204G Group carriage for the mast yellow ral 1021

Part no.	RIF	Description	Specification English	Q.ty	Maintenance	Art. group
FS1.2024G	1	Carriage	PAINTED CARRIAGE YELLOW RAL 1021	1	A-D	4402
FS1.2029	2	Pin	PIN	1		4402
FS1.2030Z	3	Plate	PLATE	2	E	4402
FS1.2031	4	Block	BLOCK	1		4402
FS1.2032	5	Pin	PIN	1		4402
FS1.2034	6	Distan. Piece	DISTANCE PIECE	2		4200
FS1.2037G	7	Bracket	BRACKET YELLOW RAL 1021	1		4402
FS1.2076	8	Spring	SPRING	2	C-D	4200
N1.1211	9	Bolt	BUTTON HEAD SCREW ISO 7380 - M8 x 20 ZINCED	6	B	4200
N1.1504	10	Screw	HEXAGON HEAD BOLT DIN 933 - M5 x 20 ZINCED	2	B	4200
N1.6117	11	Washer	WASHER UNI 6592 M8 (8.4x16x1.6) ISO7089	6		4200
N1.6138	12	Washer	WASHER DIN 7349 M8 8,4X21X4 ZINCED	4		4200
N1.6215	13	Washer	SPRING LOCK WASHER DIN 127 -B- M8 GALVANIZED	6		4200
N1.6217	14	Washer	SPRING LOCK WASHER DIN 127 -B- M5 GALVANIZED	2		4200
N1.6219	15	Washer	SPRING LOCK WASHER DIN 127 -B- M4 GALVANIZED	2		4200
N1.6315	16	Distan. Piece	DISTANCE PIECE DIN 988 DIAM. 8x14x0,5	4		4200
N1.6375	17	Washer	SPECIAL WASHER TYPE "PS" 15x21x1	2		4400
N1.7331	18	Screw	HEAD PIN SCREW DIN 7500-C M5X10 ZINCED	4		4200
N11.1116	19	Screw	CYLINDRICAL HEAD CAP SCREW M4x12 ZN DIN 912	2	B	4200
N11.1119	20	Screw	CYLINDRICAL HEAD CAP SCREW M5x20 ZN DIN 912	2	B	4200
N11.6104	21	Washer	PLAIN WASHER 15x5.3x1.2 ISO 4759/3 ZINCED	2		4200
N3.3142	22	Bush	BUSH 15X17X12	2	C	4400
N4.2154	23	Wheel	WHEEL	4	C-D	4401
N1.1228	24	Bolt	BUTTON HEAD SCREW UNI/ISO 7380 M10X25 GAL.	4	B	4200
N1.6216	25	Washer	SPRING LOCK WASHER DIN 127 -B M10 GALVANIZED	4		4200

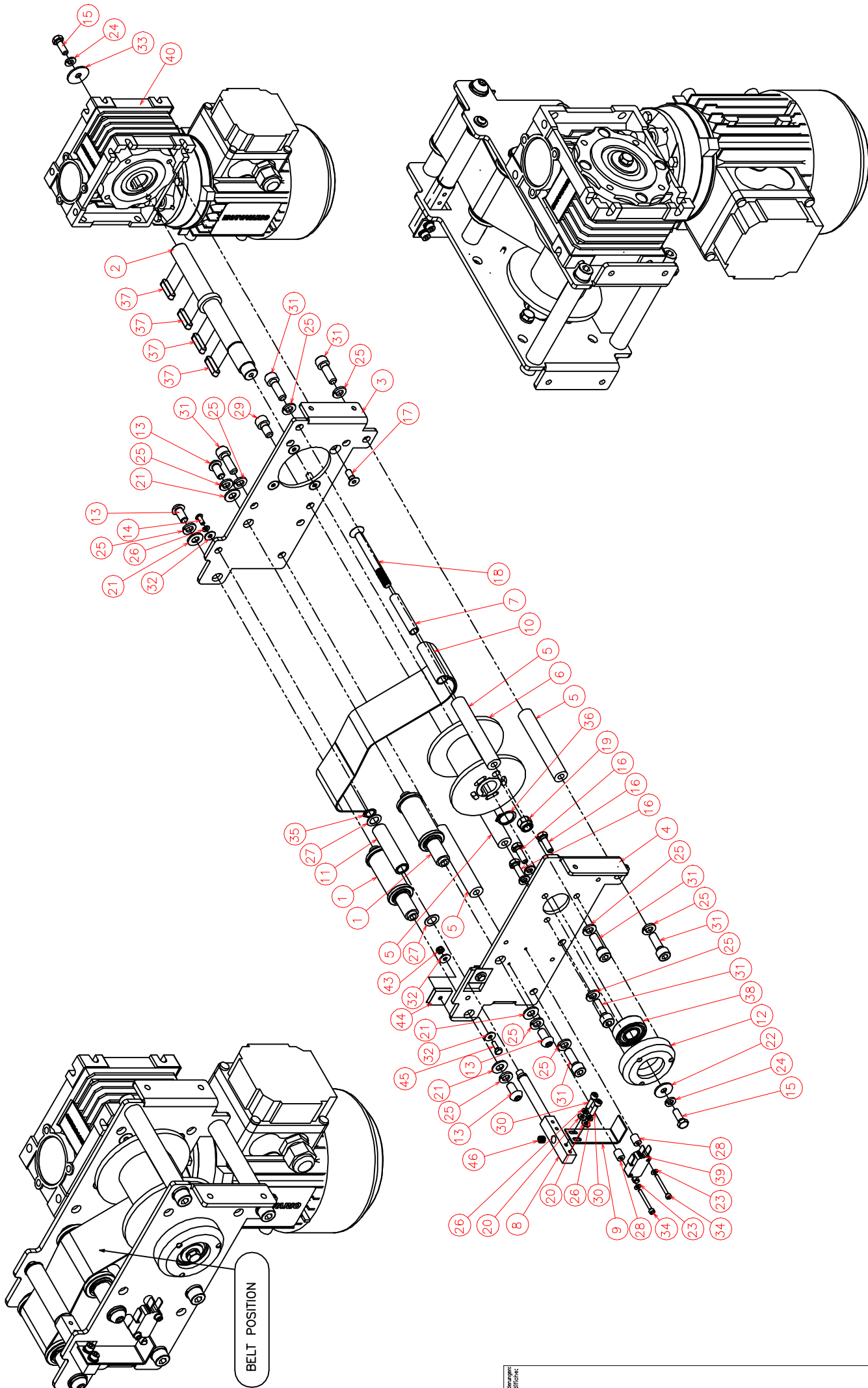

FS1.0205.V03.02

FROMM

Verdrahtung
Anschlüsse

Seitenansicht
des Motors

FS1.0205 Group Motor/gear for the belt

Part no.	RIF	Description	Specification English	Q.ty	Maintenance	Art. group
FS1.0206	1	Roll	ROLL FOR THE BELT	2	C	4410
FS1.2041	2	Shaft	SHAFT	1	C	4400
FS1.2043	3	Plate	PLATE	1		4402
FS1.2044	4	Plate	PLATE	1		4402
FS1.2045	5	Distan. piece	DISTANCE PIECE	4		4402
FS1.2048	6	Reel	REEL	1	E	4400
FS1.2054	7	Cylinder	CYLINDER	1		4402
FS1.2057	8	Block	BLOCK FOR THE SENSOR	1	C	4402
FS1.2058	9	Bracket	BRACKET FOR MICROSWITCH	1	E	4402
FS1.2065	10	Belt	BELT	1	C	4401
FS1.2068	11	Roller	CYLINDER	1	E	4402
FS3.1073	12	Flange	FLANGE	1		4402
N1.1221	13	Bolt	BUTTON HEAD BOLT ISO 7380 - M8 x 16 ZINCED	4	B	4200
N1.1230	14	Screw	BUTTON HEAD SCREW ISO 7380 - M4 x 10 ZINCED	1	B	4200
N1.1518	15	Bolt	HEXAGONAL HEAD CAP BOLT M6x18 ZN DIN 933	2	B	4200
N1.1565	16	Bolt	HEXAGONAL HEAD CAP BOLT M6x20 ZN DIN 933	3		4200
N1.2111	17	Bolt	SOCKET CTRS. HD BOLT DIN 7991-A- M6 x 12	4		4200
N1.2139	18	Bolt	SOCKET CTRS. HD BOLT DIN 7991-A- M8 x 80	1		4200
N1.5305	19	Nut	NUT DIN 985 M14 ZINCED	1		4200
N1.6115	20	Washer	PLAIN WASHER DIN 125A M4 ZINCED	2		4200
N1.6117	21	Washer	PLAIN WASHER DIN 125A M8 DIAM.8,4X16X1,6 ZN	4		4200
N1.6141	22	Washer	PLAIN WASHER 6x20x1,5 ZINCED	1		4200
N1.6190	23	Washer	WASHER M3 DIN125 Di=3,2 De=7 sp=0,5	2		4200
N1.6204	24	Washer	SPRING LOCK WASHER DIN 127 -B- M6 ZN	5		4200
N1.6215	25	Washer	SPRING LOCK WASHER DIN 127 -B- M8 ZN	11		4200
N1.6219	26	Washer	SPRING LOCK WASHER DIN 127 -B- M4 ZN	3		4200
N1.6364	27	Washer	WASHER DIN 988 10X16X0.5	2		4200
N1.6379	28	Distan. piece	DISTANCE PIECE d3,1xD8x10	2		4402
N11.1102	29	Bolt	CYLINDRICAL HEAD BOLT CL.8.8 DIN 912 M8x16 ZN	1		4200
N11.1117	30	Screw	CYLINDRICAL HEAD SCREW DIN 912 M4x16 ZN	2		4200
N11.1173	31	Screw	CYLINDRICAL HEAD CAP SCREW M8x25 ZN DIN 912	7	B	4200
N11.6106	32	Washer	PLAIN WASHER M4 4.3x12 ISO 7093 ZN	5		4200
N11.6105	33	Washer	PLAIN WASHER UNI 6593 ISO 7093 M6 6.4x24 ZN	1		4200
N12.1114	34	Screw	CYLINDRICAL HEAD SCREW DIN 912 M3x30 ZN	2		4200
N2.1101	35	Seeger	SEEGER TYPE A DIN 471 UNI 3653-7435 D.10	1	C	4400
N2.1120	36	Seeger	SEEGER TYPE H DIN 471 UNI 3653-7435 D.18	1	C	4400
N2.3307	37	Key	KEY 6x6x25 UNI 6604	4	C	4400
N3.1182	38	Ball bearing	BALL BEARING 6202.2RS1 15x35x11	1	C	4400
N5.2375	39	Microswitch	MICROSWITCH OMRON D3V-166-M1C5	1	E	4403

GROUP MOTORGear FS11x (VALID FROM SERIAL NUMBER MACHINE 03.00005)

N51.1128	40	Motor/Gear	MOTOR+GEAR	1	B-C-D-E	4401
N51.1130	41	Motor	MOTOR SIMOTOP MS632-4 POWER 0,18 KW	1	B-C-E	4403
N4.7654	42	Gear	GEAR SIZE 40 - RATIO 1/100 PAM63B14	1	B-C-D	4401

GROUP MOTORGear FS13x (VALID FROM SERIAL NUMBER MACHINE 02.00010)

N51.1128	40	Motor/Gear	MOTOR+GEAR	1	B-C-D-E	4401
N51.1130	41	Motor	MOTOR SIMOTOP MS632-4 POWER 0,18 KW	1	B-C-E	4403
N4.7654	42	Gear	GEAR SIZE 40 - RATIO 1/100 PAM63B14	1	B-C-D	4401

FS1.0205 Group Motor/gear for the belt

Part no.	RIF Description	Specification English	Q.ty	Maintenance	Art. group
N1.5307	43 Nut	NUT M4 DIN 985 SHORT GALVANIZED	2		4200
FS1.2099	44 Teflon	TEFLON	2	C	4402
N1.1556	45 Screw	HEXAGONAL HEAD CAP SCREW M4x12 ZN DIN 933	2		4200
N2.5159	46 Spring	SPRING 0.5X7X18 / 7.5	1	C	4200

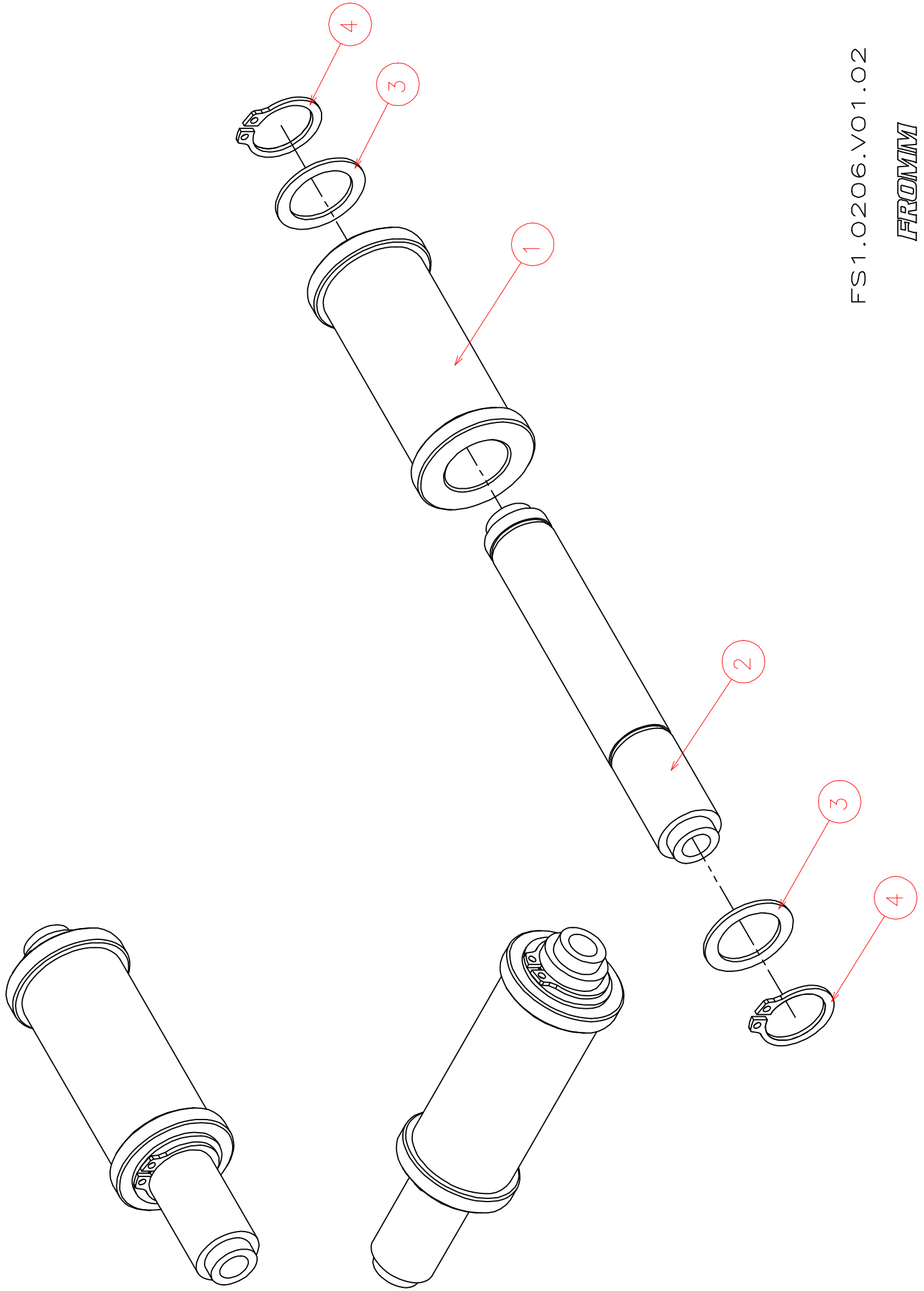

FS1.0206.V01.02

FROMM

FS1.0206 Roll for the belt

Part no.	RIF	Description	Specification English	Q.ty	Maintenance	Art. group
FS1.2013	1	Roll	ROLL	1	C	4402
FS1.2056	2	Pin	PIN	1	D	4402
N1.6375	3	Washer	SPECIAL WASHER TYPE "PS" 15x21x1	2		4400
N2.1103	4	Seeger	SEEGER TYPE A DIN 471 UNI 3653-7435 D.15	2		4200

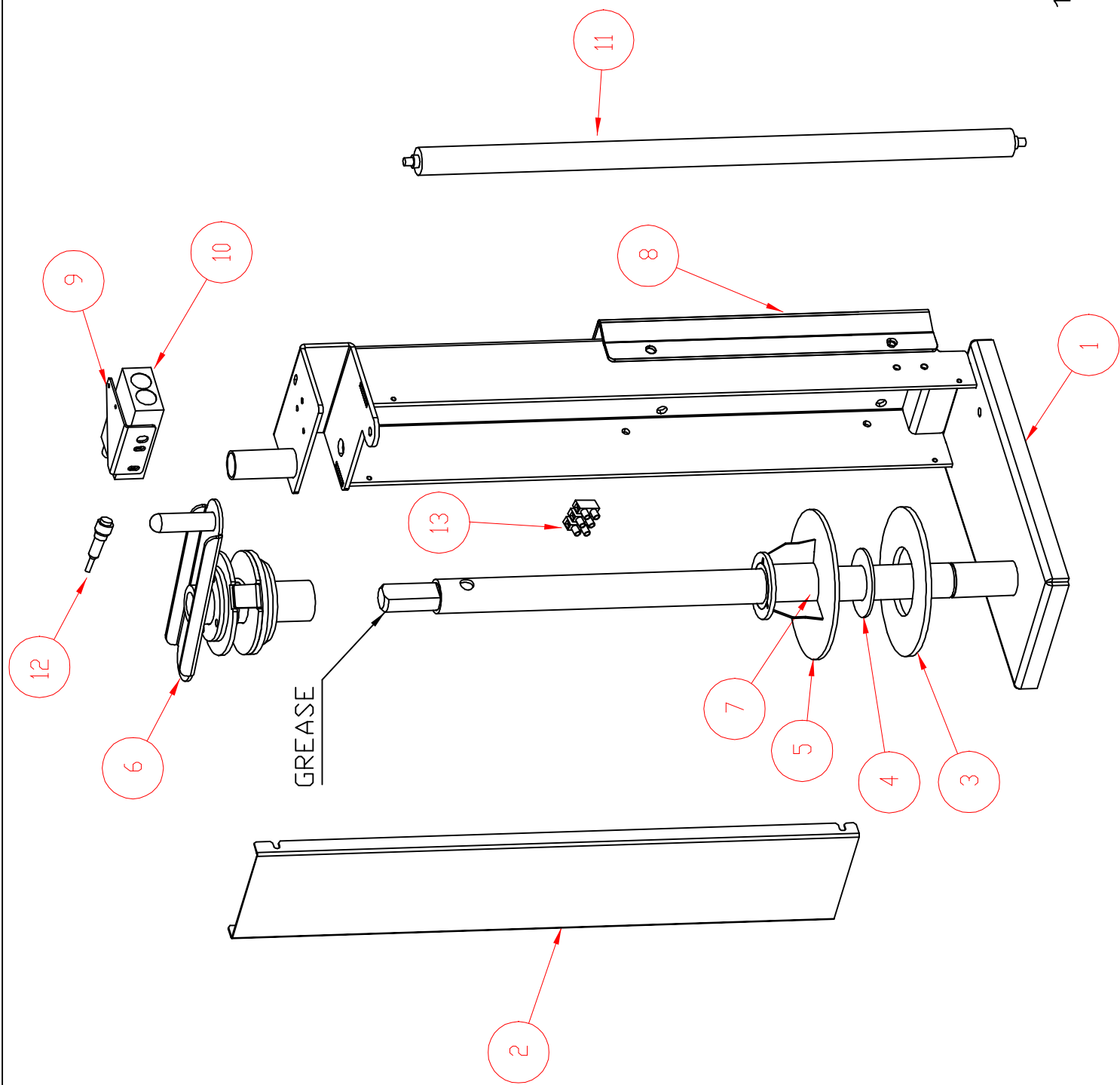

16.8440.V01

FROMM

16.8440 Carriage 0 FS1.0209G Version 01

Part no.	RIF	Description	Specification English	Q.ty	Maintenance	Art. group
FS1.2110	1	Frame	FRAME	1	A	4402
FS1.2111	2	Cover	COVER	1	A	4402
FS3.2034	3	Friction	FRICITION DISK 130x60x5	1	A-C	4401
FS1.2112	4	Washer	WASHER D.59,5xD.30,5xSP.2,5	1	A-C	4400
FS1.2113	5	Spool holder	SPOOL HOLDER	1	A	4402
FS1.2114	6	Handle	HANDLE	1	C-D	4402
FS1.2115	7	Bush	BUSH	1	A-C	4401
FS1.2116	8	Fix	FIXING CARRIAGE	1		4402
FS1.2117	9	Support	PHOTOCELL SUPPORT	1		4402
N5.2635	10	Photocell	PHOTOCELL RX8/00-1A	1	A-E	4403
N4.2210	11	Roll	ROLLS TYPE GL57 L=566MM	1	A	4402
FS3.2193	12	Cable	PHOTOCELL CABLE FS300	1	C-D	4403
N5.6701	13	Clamp	CLAMP 12 POLES	1	C-D	4403

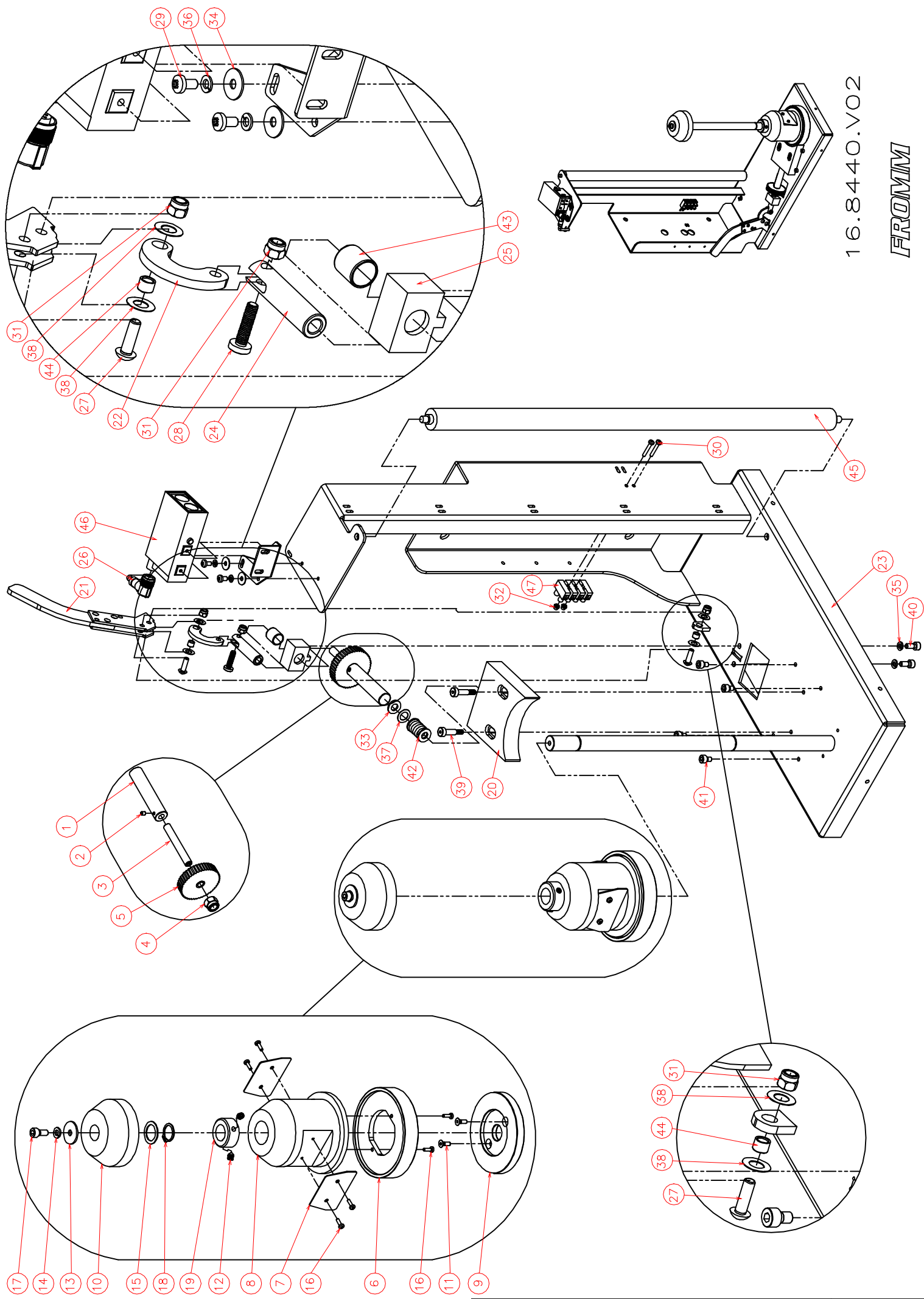

16.8440.V02

FROMM

17 14 13 10 15 18 19 12 8 7 16 6 16 11 9

31 38 44 38 27

Verwendete
Bauteile

Zeichnung: 2001
für die Montage

16.8440 Carriage 0 FS1.0214G Version 02

Part no.	RIF	Description	Specification English	Q.ty	Maintenance	Art. group
FS1.2175	1	Pin	PIN	1	A-C-D	4400
N1.3113	2	Bolt	BOLT M6x16 DIN 913 GALVANIZED	1	B	4400
N1.3149	3	Bolt	BOLT M8x60 DIN 913 GALVANIZED	1	C-D	4400
N1.5305	4	Nut	NUT M8 DIN 985 GALVANIZED	1		4200
N1.5945	5	Washer	SPECIAL WHEEL/PINION FIL. M8	1	A-E	4400
FS1.2174	6	Disk	DISK	1	A	4402
FS3.2039	7	Bracket	HARMONIC STEEL PLATE SPOOL HOLDER LOCKER	2	A-C	4402
FS3.2184	8	Holder	SPOOL HOLDER	1	A-C	4400
FS3.2211	9	Disk	DISK TO CENTRE THE SPOOL HOLDER FLANGE	1	A-C	4401
FS3.2231	10	Holder	SPOOL HOLDER CENTRAL	1	A-C	4400
N1.2180	11	Screw	SOCKET CTRS. HD BOLT DIN 7991-A- M4x12 ZN	2		4200
N1.3211	12	Bolt	BOLT M6x8 DIN 913 GALVANIZED	2	B	4200
N1.6175	13	Washer	WASHER D.6x20x1.5 ZINCED	1		4200
N1.6204	14	Washer	SPRING LOCK WASHER DIN 127 -B- M6	1		4200
N1.6325	15	Washer	WASHER TYPE "PS" 18x25x1 DIN 988	1		4200
N1.7336	16	Screw	PHILIPS HEAD SCREW 3.5x10 ZINCED UNI 9707	6		4200
N11.1136	17	Screw	CYLINDRICAL HEAD CAP SCREWS DIN 912 M6x14 ZN	1		4200
N2.1112	18	Seeger	SEEGER D.17 TYPE A DIN 471	1	C	4400
N7.2206	19	Metal ring	BLOCKING RING DIN 705 SHAPE C D. 18	1		4200
FS1.2155	20	Brake	BRAKE	1	A-C	4401
FS1.2160	21	Lever	LEVER	1		4402
FS1.2161	22	Bracket	BRACKET	1	C	4400
FS1.2165	23	Structure	WELDED STRUCTURE	1	A	4402
FS1.2168	24	Piston	PISTON	1	A-C-D	4400
FS1.2172	25	Block	BLOCK	1	A-C	4402
FS1.2178	26	Cable	CABLE FOR PHOTOCELL	1	C	4403
N1.1225	27	Screw	BUTTON HEAD SCREW M5x16 GALVANIZED ISO 7380	2	C	4400
N1.1904	28	Screw	PHILIPS HEAD SCREW M5x20 GALVANIZED DIN 7985	1	C	4400
N1.1911	29	Screw	PHILIPS HEAD SCREW M4x8 GALVANIZED DIN 7985	2		4200
N1.1916	30	Screw	PHILIPS HEAD SCREW 3x20 ZINCED DIN 7985A	2		4200
N1.5302	31	Nut	NUT M5 ZN DIN 985	3		4200
N1.5313	32	Nut	NUT M3 ZN DIN 985	2		4200
N1.6117	33	Washer	PLAIN WASHER M8 ZINCED DIN 435	1		4200
N1.6160	34	Washer	PLAIN WASHER M4 ZINCED DIN 435	2		4200
N1.6217	35	Washer	SPRING LOCK WASHER DIN 127 -B- M5	2		4200
N1.6219	36	Washer	SPRING LOCK WASHER DIN 127 -B- M4	2		4200
N1.6364	37	Washer	WASHER TYPE "PS" 16x10x0.5 DIN 988	1		4400
N1.6382	38	Washer	WASHER TYPE "PS" 7x13x0.3 DIN 988	4		4400
N1.7116	39	Screw	CYLINDRICAL HEAD CAP SCREWS M5 6x16 ZN	2		4200
N11.1101	40	Screw	CYLINDRICAL HEAD CAP SCREWS M5x12 ISO4762 ZN	2		4200
N11.1134	41	Screw	CYLINDRICAL HEAD CAP SCREWS M5x8 ISO4762 ZN	4		4200
N21.5122	42	Spring	SPRING	1	C	4400
N3.3119	43	Bush	GLYCODUR PG121415F	1	C-D	4400
N3.3161	44	Bush	BUSH 5x7x5 - MB0505DU	1	C-D	4400
N4.2210	45	Roll	ROLLS TYPE GL57 L=566MM	1	A	4402
N5.2635	46	Photocell	PHOTOCELL RX8/00-1A	1	A-E	4403
N5.6701	47	Clamp	CLAMP 12 POLES	1	C	4403

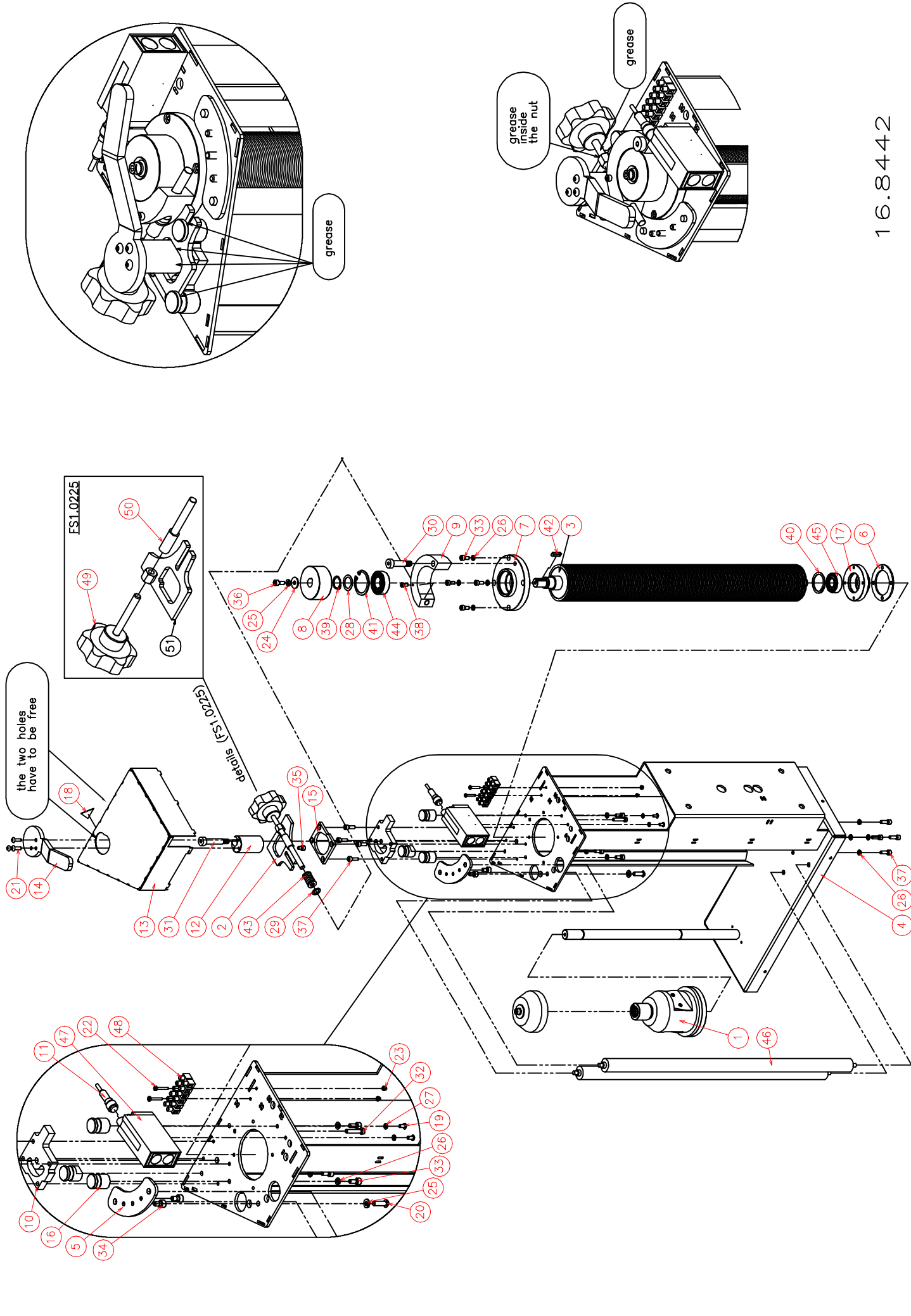

16.8442

FROMM

16.8442 Carriage 2 FS1.0222G

Part no.	RIF	Description	Specification English	Q.ty	Maintenance	Art. group
FS1.0220	1	Group	GROUP SPOOL-HOLDER	1	A-C	4410
FS1.0225	2	Group	GROUP SLIDE	1	A-C-E	4410
N4.1942	49	Handle	HNADLE VP/60 - M8x60	1	A-C-E	4400
FS1.2203	50	Pin	PIN	1	D	4400
FS1.2211	51	Plate	PLATE	1	A-C-E	4402
FS1.2170	3	Roll	RUBBER ROLL	1	A-C	4402
FS1.2190G	4	Structure	STRUCTURE YELLOW RAL1021 LIQUID PLAIN PAIN.	1	A-C	4402
FS1.2193	5	Plate	PLATE	1		4402
FS1.2194	6	Disk	DISK	1		4402
FS1.2198	7	Flange	FLANGE	1		4402
FS1.2199	8	Roll	FRICTION ROLL	1	A-C	4402
FS1.2202	9	Brake	CARRIAGE BRAKE	1	A-C-E	4401
FS1.2209	10	Plate	PLATE	1		4402
FS1.2216	11	Cable	PHOTOCELL CABLE	1	C	4403
FS1.2225	12	Eccentric	ECCENTRIC	1	C-D	4402
FS1.2226G	13	Carter	CARTER YELLOW RAL1021 LIQUID PLAIN PAIN.	1	A	4402
FS1.2228	14	Lever	LEVER	1	A-C-E	4402
FS1.2231	15	Plate	PLATE	1		4402
FS1.2232	16	Guide	GUIDE	3	C-D-E	4402
FS3.2209	17	Flange	FLANGE	1		4402
FS3.2341	18	Label	ANTI-CRUSHING LABEL	1	C	4405
N1.1213	19	Screw	BUTTON HEAD SCREW 4x8 ZINCED ISO 7380	2		4200
N1.1222	20	Screw	BUTTON HEAD SCREW ISO 7380 - M6 x 20	1		4200
N1.1225	21	Screw	BUTTON HEAD SCREW ISO 7380 - M5 x 16	3		4200
N1.1916	22	Screw	PHILIPS HEAD SCREW 3x20 ZINCED ISO 7045	2		4200
N1.5313	23	Nut	NUT M3 ZN DIN 985	2		4200
N1.6141	24	Washer	PLAIN WASHER D.6x20x1.5 ZINCED	1		4200
N1.6204	25	Washer	SPRING LOCK WASHER DIN 127 -B- M6	2		4200
N1.6217	26	Washer	SPRING LOCK WASHER DIN 127 -B- M5	11		4200
N1.6219	27	Washer	SPRING LOCK WASHER DIN 127 -B- M4	2		4200
N1.6327	28	Washer	WASHER TYPE "PS" 20x28x0.5 DIN 988	1		4200
N1.6364	29	Washer	WASHER TYPE "PS" 10x16x0.5 DIN 988	1		4200
N1.7101	30	Bolt	CYLINDRICAL HEAD BOLT 10x30 M8	1	B	4200
N1.7103	31	Bolt	CYLINDRICAL HEAD BOLT 10x40 M8	1	B	4200
N1.7338	32	Screw	HEAD PIN SCREW M5x25 ZINCED UNI 8112	1		4200
N11.1101	33	Bolt	CYLINDRICAL HEAD BOLT CL.8.8 DIN 912 M5x12 ZN	7		4200
N11.1121	34	Bolt	CYLINDRICAL HEAD BOLT CL.8.8 DIN 912 M6x10 ZN	2		4200
N11.1134	35	Screw	CYLINDRICAL HEAD CAP SCREWS DIN 912 M5x8 ZN	1		4200
N11.1136	36	Screw	CYLINDRICAL HEAD CAP SCREWS DIN 912 M6x14 ZN	1		4200
N11.1147	37	Screw	CYLINDRICAL HEAD CAP SCREWS DIN 912 M5x16 ZN	8		4200
N11.1162	38	Screw	CYLINDRICAL HEAD SCREW DIN 912 M4x10 GAL.	1		4200

16.8442 Carriage 2 FS1.0222G

Part no.	RIF Description	Specification English	Q.ty	Maintenance	Art. group
N2.1108	39 Seeger	SEEGER D.20 TYPE A DIN 471	1		4200
N2.1206	40 Seeger	SEEGER FOR HOLES D.35 TYPE J	1		4200
N2.1222	41 Seeger	SEEGER D.42 TYPE "J" UNI 3654/7437	1		4200
N2.3305	42 Key	KEY 5x5x20 DIN 6885	1		4200
N21.5122	43 Spring	SPRING Dh=16 Dd=8 Lo=25 ISO 10243	1	C	4400
N3.1151	44 Ball bearing	BALL BEARING 6004 2RS 20x42x12	1	A-D	4400
N3.1182	45 Ball bearings	BALL BEARING 15x35x11 6202.2RS	1	A-D	4400
N4.2210	46 Roll	ROLLS TYPE GL57 L=566MM	2	A	4402
N5.2635	47 Photocell	PHOTOCELL RX8/00-1A	1	A-E	4403
N5.6701	48 Clamp	CLAMP 12 POLES	1	C	4403

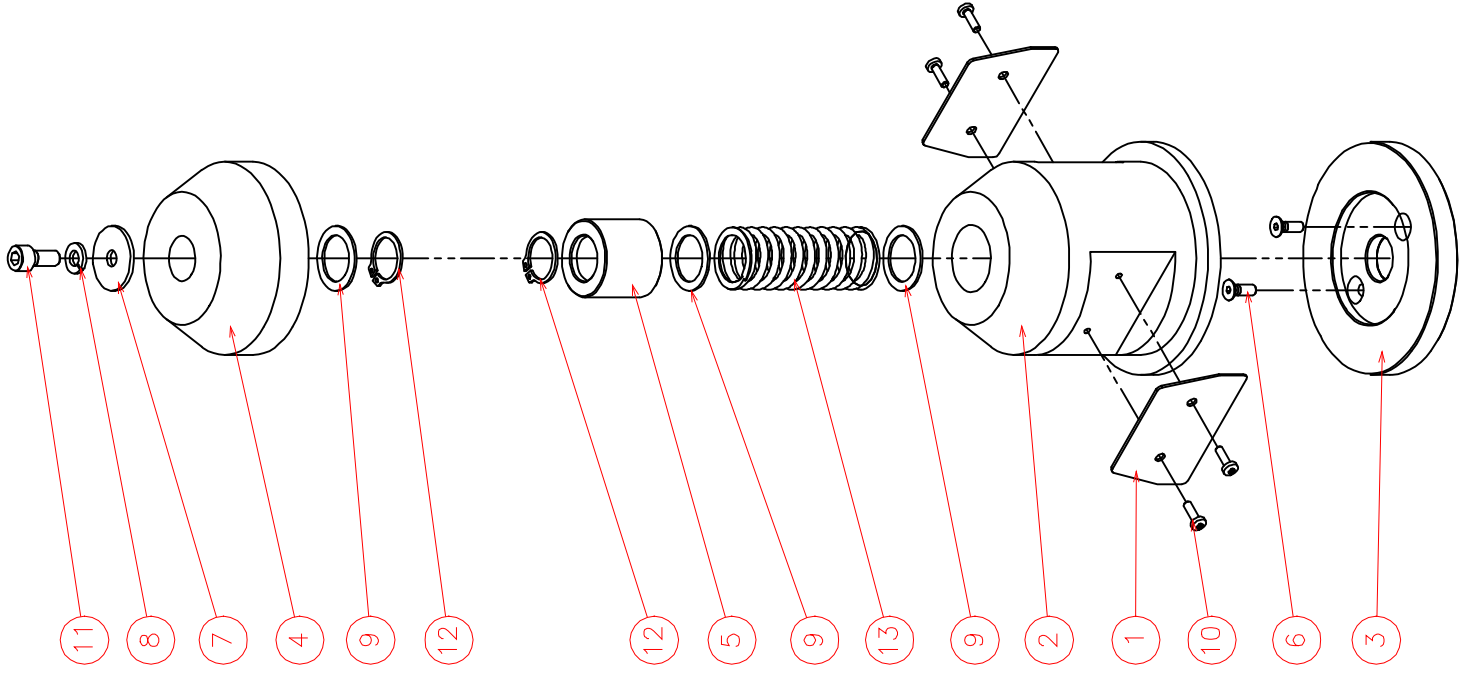

FS1.0220

FROMM

FS1.0220 Group Spool-Holder

Part no.	RIF	Description	Specification English	Q.ty	Maintenance	Art. group
FS3.2039	1	Bracket	HARMONIC STEEL PLATE SPOOL HOLDER LOCKER	2	A-C	4402
FS3.2184	2	Holder	SPOOL HOLDER	1	A-C	4400
FS3.2211	3	Disk	DISK TO CENTRE THE SPOOL HOLDER FLANGE	1	A-C	4401
FS3.2231	4	Holder	SPOOL HOLDER CENTRAL	1	C	4400
FS3.2385	5	Block	BLOCK FOR THE SPRING	1		4402
N1.2180	6	Screw	SOCKET CTRS. HD BOLT DIN 7991-A- M4x12 ZN	2		4200
N1.6175	7	Washer	WASHER D.6x20x1.5 ZINCED	1		4200
N1.6204	8	Washer	SPRING LOCK WASHER DIN 127 -B- M6	1		4200
N1.6325	9	Washer	WASHER TYPE "PS" 18x25x1 DIN 988	3		4200
N1.7336	10	Screw	PHILIPS HEAD SCREW 3.5x10 ZINCED UNI 9707	4		4200
N11.1136	11	Screw	CYLINDRICAL HEAD CAP SCREWS DIN 912 M6x14 ZN	1	B	4200
N2.1112	12	Seeger	SEEGER D.17 TYPE A DIN 471	2	B	4400
N21.5120	13	Spring	SPRING D.INT.24.1 L=67.5	1	B-C	4400