



Specifications

MODELS	RX6/0*-1 RX8/0*-1 RXS/0*-1 RXL/0*-1	RXC/0*-1 RXP/0*-1	RXX/0*-1 RXR/0*-1	RX6/0*-3 RX8/0*-3 RXS/0*-3 RXL/0*-3	RXC/0*-3 RXP/0*-3	RXE/0*-3 RXR/0*-3
	DC			AC-DC		
Differential travel	2...10%Sn		10%Sn	2...10%Sn		10%Sn
Repeat accuracy	5%					
Operating voltage	10-30Vdc			20-253Vac / 20-60Vdc		
Ripple	≤10%			-		
No-load supply current	25mA 40mA (RXS-RXL)	35mA 25mA		25mA 30mA (RXS-RXL)	15mA 25mA	
Load current	100mA			3A-250Vac / 3A-30Vdc (750VA / 90W)		
Leakage current	<10µA			-		
Voltage drop	1,2V max.			-		
Output type	static (DECOUT®)			relay		
Switching frequency	500Hz	250Hz		25Hz		
Supply electrical protections	polarity reversal, transient			transient (AC), over voltages (DC)		
Output electrical protections	short circuit (with hold)			-		
Temperature range	-25...+70 °C (without freeze)					
Temperature drift	±10% Sr					
Interference to external light	≥5000lux	≥10000lux		≥5000lux	≥10000lux	
Protection degree	IEC IP 65					
LED indicators	red (output state), red (alignment), green (stability)					
Emitter LED indicators	green (check), red (dist.x2)			green (supply), red (dist.x2)		
Housing material	polycarbonate (glass fiber reinforced)					
Lenses material	PMMA					

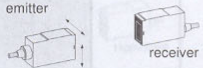

Alignment

The following instructions are referred to NO modality. Please refer to the following operation mode table:

1) - Through beam models RXX-RXR and RXE-RXR (sensing distance Sn =16-32m)

	Adjustment	State
1	Using the supplied mounting bracket, place emitter and receiver in face to face within the sensing distance (select x1, 16 m or x2, 32m on emitter) by eye and fix them tentatively.	
2	Shift the emitter upward, downward and sideways to find the point where the alignment LED (red) on the receiver goes on.	
3	Shift the receiver upward, downward and sideways to find the point where the stability LED (green) goes on. Fix emitter and receiver firmly and proceed to sensitivity adjustment.	

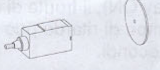
2) - Retro-reflective RXC (Sn=12m) and polarized models RXP (Sn=6m)

	Adjustment	State
1	Place the sensor and the reflector in face to face within the sensing distance by eye measure and fix them tentatively.	
2	Shift the sensor upward, downward and sideways to find the point where the alignment LED (red) and the stability LED (green) go on. Fix the sensor firmly and proceed to sensitivity adjustment.	

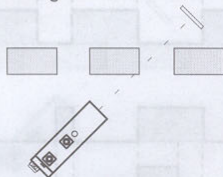

When the detected target is glossy or has a high reflection factor please use the polarized retro-reflective models (RXP). In the case of using the retro-reflective models (RXC), tilt the sensor optical axis to avoid the high reflection factor.



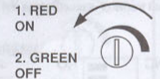
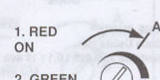

Reflectors table

Models	RL100D	RL104	RL106	RL110	RL111G	RL112G	RL113G	RL116
Distance % RXC	50%	45%	55%	100%	50%	45%	95%	90%
Distance % RXP	46%	42%	53%	100%	39%	32%	95%	85%

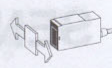
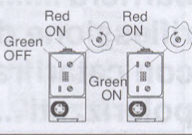

Sensitivity adjustment (through beam, retro-reflective, polarized models)

	Adjustment description	trimmer position
1	Without the target, the alignment LED (red) and the stability LED (green) are in on-state. Rotate the sensitivity adjustment trimmer counterclockwise until the stability LED (green) goes off. Next, rotate the sensitivity adjustment trimmer clockwise until the stability LED (green) goes on. This point (position A) gives the best sensitivity and allow to detect the presence or absence of target with the equal precision and good safety margins. If the target is detectable without problems it is possible rotate the trimmer clockwise over A position to obtain further safety margins.	 
2	Place the target along the optical axis and by moving check that the alignment LED (red) and the stability LED (green) go off. Next, fix the plastic cover with the fixing screw verifying the right gasket position to maintain the IP65 protection degree.	

(3) - Diffuse reflection models RX6 (Sn=1m), RX8 (Sn=2m)

	Adjustment	State
1	Keep the optical axis perpendicular to the target direction of movement. Fix the sensor definitively at a distance ≤ Sn.	
2	With the target, the alignment LED (red) and the stability LED (green) are in on-state. Rotate the sensitivity adjustment trimmer counterclockwise until the stability LED (green) goes off. Next, rotate the sensitivity adjustment trimmer clockwise until the stability LED (green) goes on. This point (position A) allow to work in optimal conditions.	
3	Remove the target from the optical axis and check that the alignment LED (red) and the stability LED (green) go off. Next, fix the plastic cover with the fixing screw verifying the right gasket position to maintain the IP65 protection degree.	

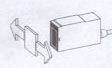
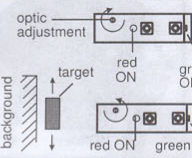
(4) - Background suppression models RXS (Sn=0,05-0,3m) and RXL (Sn=0,25-0,7m)

	Adjustment	State
1	Keep the optical axis perpendicular to the target direction of movement. Fix the sensor definitively at a distance ≤ Sn.	
2	Rotate the optical adjustment screw till the maximum clockwise position. Consider the worst operating conditions: darkest target placed as close as possible to the background. Place the target in front to the sensor; turn the optical adjustment screw counterclockwise till the alignment LED (red) and the stability LED (green) go on.	
3	Remove the target from the optical axis and check that the alignment LED (red) and the stability LED (green) go off. Next, fix the plastic cover with the fixing screw verifying the right gasket position to maintain the IP65 protection degree.	

Timing functions are available for all models (see timing chart).

Dimensions

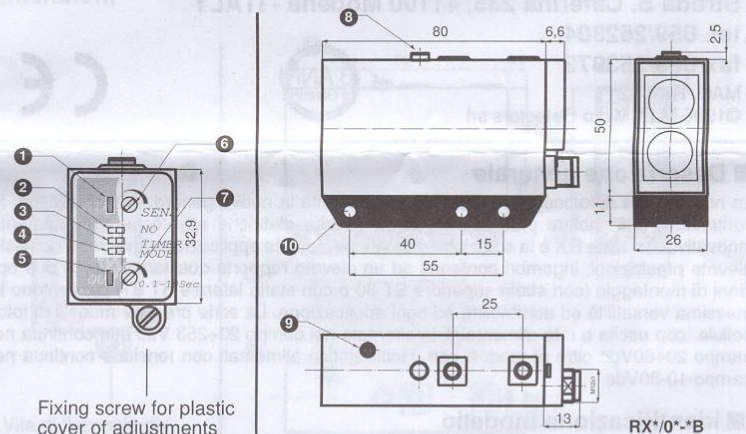

1	Green Led: stability (RX6, RX8, RXC, RXP, RXS, RXL, RXR) - check off (RXX), supply voltage (RXE)
2	NO/NC selection switch (RX6, RX8, RXC, RXP, RXS, RXL, RXR) - Distance x1/x2 (RXX, RXE)
3	Switch selecting timer function Delay on (models with timer function only)
4	Switch selecting timer function Delay off (models with timer function only)
5	Red Led: output state (RX6, RX8, RXC, RXP, RXS, RXL, RXR) - Distance x2 (RXX, RXE)
6	Sensitivity adjustment trimmer (not available for RXX, RXE, RXS and RXL models)
7	Trimmer for timer function adjustment 0,1-10s (not available for RXX and RXE)
8	Alignment red Led (not available for RXX and RXE)
9	Screw for optic adjustment (available only for background suppression models RXS and RXL)
10	Plastic slide for mounting with ST81 bracket (not available for option A models)

Plug connectors

Use preferably the following types of DIELL connectors:

CD12M/OB-*A1** - M12 axial plug connectors with tang, 4 poles, CEI 2022 II, 2, 5, 7 and metres - (**=020 for 2m, 050 for 5m, 070 for 7m and 100 for 10m)
CD12M/OB-*C1** - M12 right angle plug connectors with tang, 4 poles, CEI 2022 II, 2, 5 and 10 metres.

N.B. - It's very important to lock the connector nut to maintain IP65 protection degree of the sensor.

Accessories

Use preferably **ST 82** screwdriver supplied with the sensors to adjust the trimmers or remove protection screws.

ST80 bracket - Supplied for sensors without plastic slide (option A models).

ST81 bracket - Supplied for sensors with plastic slide (option B models).

RX Series

PHOTOELECTRIC SENSORS

- through beam 16 - 32m
- diffuse reflection 1 - 2m
- retro-reflective 12m
- polarized retro-reflective 6m
- background suppression .. 0,05-0,3 / 0,25-0,7m

OPERATING INSTRUCTIONS

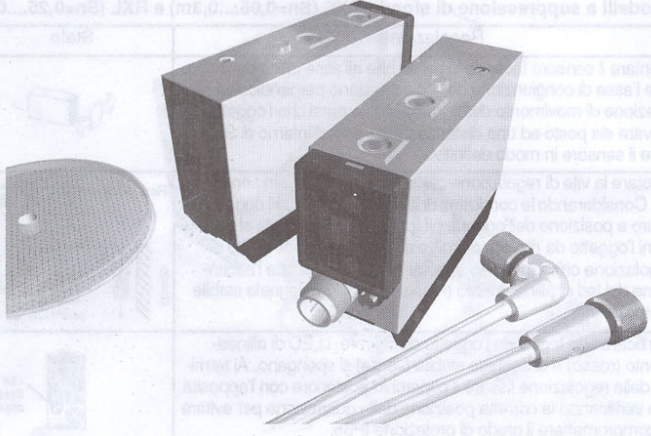

M.D. Micro Detectors S.r.l.
 Strada S. Caterina 235, 41100 Modena - ITALY
 tel. 059/252304
 fax 059/253973
 MAN. RX-002/UK
 ©1996 M.D. Micro Detectors srl



Wiring diagram

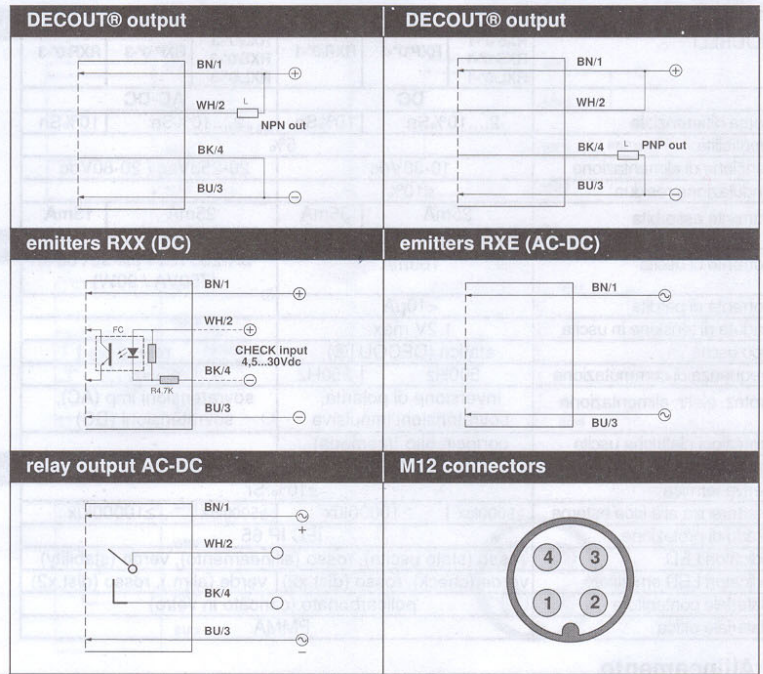

1. Make sure that the supply voltage is correctly settled with maximum ripple specified in the catalogue.
2. For DC supply a class 2 source is required.
3. In case of noise interference induced by the power lines higher than the admitted one, separate the wiring of the sensor (DC types) from the power and high voltage lines or place the sensor cable in an earthed metal channel. Otherwise the sensor may malfunction due to electric noise.

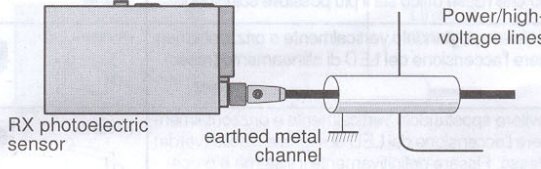

4. The output state requires 100ms to become ready after the power has been applied (see "Time delay before availability").

Timing chart

In the T models (with timer function) it's possible to obtain a delay of the turn-on instant (delay ON), turn-off instant (delay OFF) or to select ONE SHOT mode. The delay time can be adjusted from 0,1 to 10 seconds through the special adjustment trimmer.

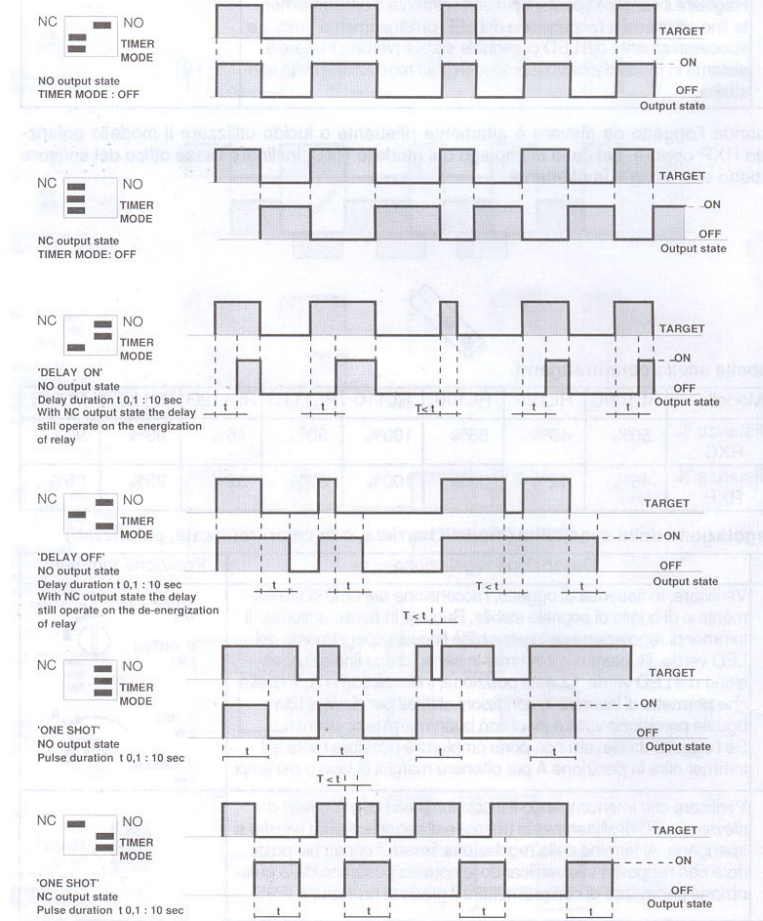

General description

The new series of photoelectric switches DIELL RX represents an innovative generation of sensors with plastic rectangular housing and with electrical and optical features extremely advanced. The RX series is the best solution for all applications requiring high performances, reduced overall dimensions and high relation quality/price; the two mounting options (with superior bracket and with lateral bracket) allow maximum versatility for any applications. This series is provided with models of photoelectric sensors with relay output and which can be supplied in AC from 20 to 253 Vac and in DC from 20 to 60 Vdc, moreover the models with static output which are supplied in DC from 10 to 30 Vdc.

Ordering system

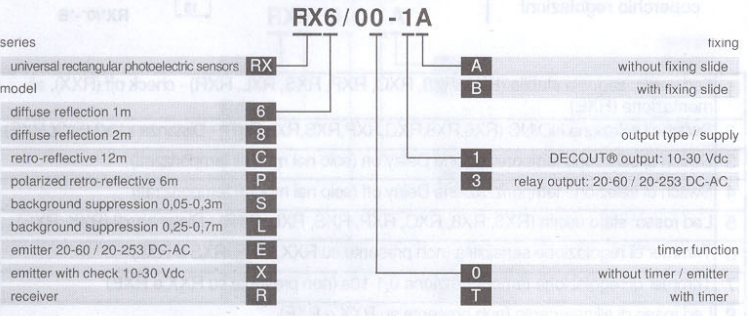

Installation

A double installation is possible:
 - with ST 80 suitable bracket (option A models)
 - with ST 81 side bracket (option B models)

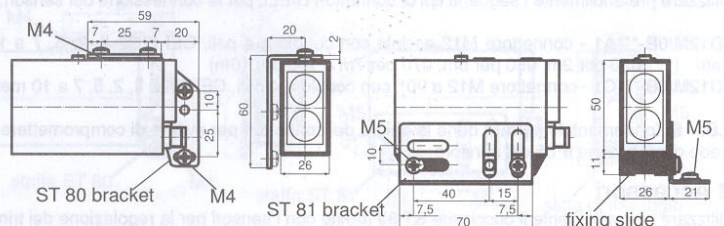

1. Do not use the sensor where it may be exposed to dust, water, steam etc. which could affect detection.
2. The sensor head should not be exposed to organic solvents.
3. Do not allow a strong light such as sun light to radiate directly on the sensor.