

Instructions for use

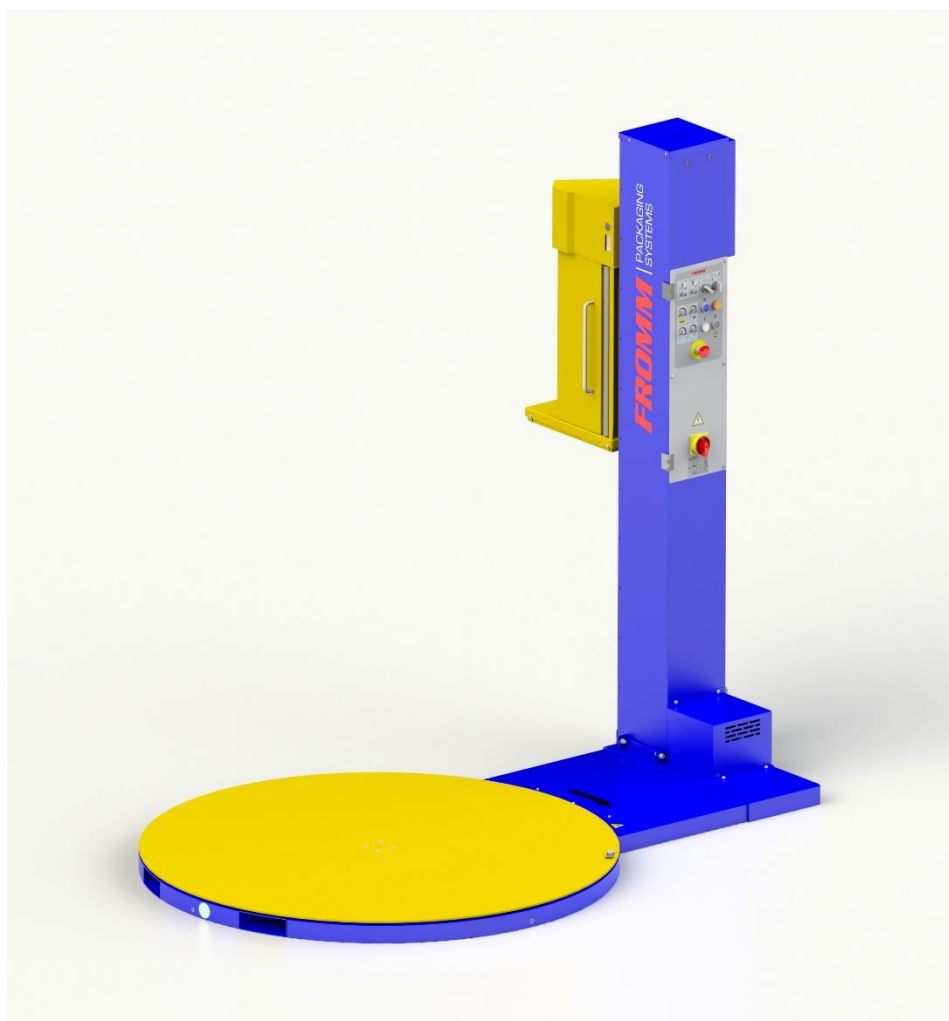

SEMI-AUTOMATIC WRAPPER Series FS360

FS360.V01.EN02 from SERIAL NUMBER 01.00961



IMPORTANT!

**Read the instructions carefully before installing and before using this machine for the first time, so as to avoid causing damage to yourself and to your machine.
Store for further consultation.**

INDEX

CHAP.1	CONTENTS AND CONSULTATION METHOD	4
1.1.	PURPOSE OF THE MANUAL.....	4
1.1.1.	IMPORTANCE OF THE MANUAL	4
1.1.2.	STORAGE, UPDATES, ADDITIONS AND REPLACEMENT	4
1.2.	MEANING OF THE SYMBOLS	5
1.3.	DEFINITIONS	8
CHAP.2	GENERAL INFORMATION AND CHARACTERISTICS	11
2.1.	TECHNICAL FEATURES.....	11
2.1.1.	PURPOSE - AIM - CONSTRUCTIVE PARTS.....	11
2.1.2.	PERFORMANCE	13
2.1.3.	TECHNICAL AND CONSTRUCTIVE DATA OF SUPPLY	13
2.2.	PROCESSED PRODUCTS - HANDLED OR GENERATED.....	13
2.3.	EMISSION OF AIRBORNE NOISE.....	14
2.4.	SERVICE CONDITIONS.....	15
2.5.	ELECTRICAL EQUIPMENT POWER SUPPLY	16
2.6.	NORMAL, IMPROPER, INCORRECT / FORBIDDEN / REASONABLY PREDICTABLE INCORRECT USE	18
CHAP.3	CONSISTENCY OF SUPPLY	24
3.1.	MACHINE IDENTIFICATION	24
3.2.	CERTIFICATION.....	24
3.3.	WARRANTY CONDITIONS	25
3.4.	DECLARATION OF CONFORMITY.....	26
CHAP.4	SAFETY INSTRUCTIONS	27
4.1.	INTRODUCTION.....	27
4.2.	OBLIGATIONS AND DUTIES	28
4.2.1.	PLANT MANAGEMENT OBLIGATIONS.....	28
4.2.2.	PERSONNEL MAIN REQUIREMENTS	28
4.3.	ENVIRONMENTS, WORK AND TRANSITING PLACES.....	30
4.4.	GENERAL MACHINE PROTECTION REGULATIONS	31
4.5.	MOVING STRUCTURES	32
4.6.	LIFTING MEANS.....	32
4.7.	PERSONAL PROTECTIVE EQUIPMENT AND FIRST AID.....	32
4.8.	INDICATIONS ON RESIDUAL RISKS PRESENT	33
4.9.	PLATES	42
4.10.	DESCRIPTION OF THE SAFETY FUNCTIONS.....	44
CHAP.5	TRANSPORT, INSTALLATION AND HANDLING	58
5.1.	STORAGE, TRANSPORT AND HANDLING	58
5.1.1.	STORAGE	58
5.1.2.	SIZE, WEIGHT AND HANDLING OF THE INDIVIDUAL PARTS.....	59
5.1.3.	REMOVING THE PACKAGE - OPENING INSTRUCTIONS.....	64
5.2.	PRELIMINARY PREPARATION AND ADJUSTMENT OPERATIONS	66
5.2.1.	FILM LOADING.....	66
5.2.2.	CARRIAGE BRAKING SYSTEM.....	68
5.3.	POWER SUPPLIES.....	69
5.3.1.	ELECTRIC	69
CHAP.6	USING THE MACHINE.....	71
6.1.	DESCRIPTION OF ACTUATORS, SIGNS AND ALARMS	71
6.1.1.	COMMAND AND SIGNALLING ACTUATORS	71
6.1.2.	START-UP FUNCTIONS	75
6.1.3.	SETTING OF PRODUCTION / PROGRAMMING PARAMETERS	76
6.1.3.1.	LIST OF ALARMS.....	76
6.2.	PROCESSING CYCLE	78
6.3.	CYCLE STOP	79
6.4.	SWITCH-OFF.....	80
CHAP.7	MAINTENANCE.....	81
7.1.	ROUTINE MAINTENANCE.....	82
7.1.1.	INTERVENTIONS EXECUTABLE BY THE OPERATORS.....	83
7.1.2.	INTERVENTIONS EXECUTABLE BY MAINTENANCE TECHNICIANS ONLY.....	84
7.2.	EXTRAORDINARY MAINTENANCE	87
7.2.1.	OPERATIONS THAT CAN ONLY BE PERFORMED BY MANUFACTURER TECHNICIANS	87
7.3.	CLEANING.....	88
CHAP.8	DEMOLITION AND DISPOSAL	91
8.1.	DEMOLITION.....	91
8.2.	DISPOSAL	92
CHAP.9	IDENTIFICATION DATA.....	93
9.1.	MANUFACTURER	93

9.2. MACHINE TYPE 93
9.3. DOCUMENT 93

CHAP.1 CONTENTS AND CONSULTATION METHOD

1.1. PURPOSE OF THE MANUAL

1.1.1. IMPORTANCE OF THE MANUAL

This manual is to be considered **an integral part of the machine**:

1. This manual refers solely to the type of pallet semi-automatic wrapper supplied
2. it must be kept throughout the machine life span
3. it must accompany the machine if transferred



In accordance with current standards, the company department managers where this machine is installed must carefully read this document and have the parts of pertinence, read by the operators and maintenance technicians in charge.

The time required to do so will be greatly rewarded by the machine correct operation and its safe use.

Text, drawings and diagrams contained in this operating manual are of a reserved technical nature and belong to FROMM and can not be reproduced in any way, either in part or in whole.



The user must carefully read this manual before intervening on the machine.

This manual is an essential and integrating part of the machine. It contains important information the knowledge of which is essential for correct and safe intervention.

The machine must only be used for the purpose it is expressly intended, programmed and commercialised for.

Any use of the machine other than that indicated in chapter 2 is to be considered improper and, therefore, the manufacturer shall not be liable.

The manufacturer cannot be considered liable for any fault caused by the unreasonable, improper and/or wrong use.

Contact the distributor FROMM if in doubt.

1.1.2. STORAGE, UPDATES, ADDITIONS AND REPLACEMENT



1. This operating manual must be stored in the immediate proximity of the machine.
2. Consult the manual, without damaging all or part of its content.
3. Do not remove the pages from the manual.
4. Do not write on the manual pages. Appropriate tables are provided for making notes.

1.2. MEANING OF THE SYMBOLS

The meaning of the symbols and definitions used in this document is clearly specified below.



DANGER

It indicates the presence of a danger for those working on the machine or near it: the signalled activity must, therefore, be carried out respecting the current accident-prevention standards and indications in this manual.



PRECAUTION

It indicates a warning on useful information and/or further recommendations and/or solutions concerning the operation in progress.



ATTENTION

It indicates an operation to be carefully performed to avoid damaging the machine.



OPERATOR

Qualified and authorised person in charge of running the machine with protections active and load and/or unload with material being processed.



MECHANICAL TECHNICIAN

Qualified and authorised technician able to install and perform routine and/or extraordinary maintenance of mechanical nature only.



ELECTRICAL TECHNICIAN

Qualified and authorised technician able to install and perform routine and/or extraordinary maintenance of electrical nature only.









AUTHORISED SERVICE CENTRE



Qualified and authorised technician able to install and perform routine and/or extraordinary maintenance of electrical and mechanical nature.

SAFETY PICTOGRAMS

Pictograms depicted inside a triangle denote the presence of DANGER. Pictograms depicted inside a circle refer to OBLIGATIONS/PROHIBITIONS. Example of some pictograms.

Symbol	Name
	Dangerous electrical voltage
	High temperature
	Crushing of upper limbs
	Hitting of head
	Generic danger

Symbol	Name
	Slipping
	Tripping on obstacles
	Cutting parts
	No access to unauthorised persons
	Do not remove the safety devices
	Prohibition to manually clean, oil, grease, repair or adjust moving parts
	Prohibition to work before having disconnected voltage
	No smoking
	it is forbidden to use naked flames or incandescent parts
	Do not drill holes in the structural parts
	Obligatory protective gloves
	Obligatory safety footwear
	Eye protection
	Obligatory hard hat
	Obligatory hearing protection
	Obligatory body protection

Symbol	Name
	Obligatory mouth and nose protection with mask (category II)
	Obligatory face protection

1.3. DEFINITIONS

DANGER ZONE

Any zone within and/or around machinery in which a person is subject to a risk to his health or safety (Annex I, art. 1.1.1 Directive 2006/42/EC).

EXPOSED PERSON

Any person wholly or partially in a danger zone (Annex I, art. 1.1.1 Directive 2006/42/EC).

OPERATOR IN CHARGE OF PRODUCTION AND OF RUNNING THE MACHINE

Person in charge of running the machine according to the destination of use, informed of the residual risks of the functions required for use, cleaning, adjustment, etc. with the sole use of the hands or special tools made available by the manufacturer. The operator does not have a toolbox at hand.

INTEGRATOR

Person in charge of integrating the partly completed machine with equipment, components and other partly completed machines or machines intended for specific applications

MAINTENANCE TECHNICIAN

Person in charge of maintaining the machine according to the destination of use, informed of the residual risks and authorised to carry out transport, handling, installing, adjusting, servicing, cleaning, repair, dismantling, disposal interventions, etc., also with the use of tools normally available to maintenance technicians and taken from the available tool box.

ROUTINE MAINTENANCE

Set of operations, set forth by the manufacturer and detailed in the instructions booklet, whose purpose is to limit over time the normal wear and tear of the machine and prevent the occurrence of faults or anomalies (e.g. cleaning, adjustment, lubrication operations, etc.).

EXTRAORDINARY MAINTENANCE

Set of repair or replacement operations that allow the machine to continue operating in normal conditions of use. The installed components must be identical to the previous ones, or equivalent in terms of performance, size etc., according to the specifications provided by the manufacturer.

SUBSTANTIAL CHANGE

Set of operations implemented on a machine to adapt its productivity to new requirements or to allow it to operate after replacing a part with a non-equivalent one, therefore requiring adaptations or procedures that involve a change to the methods of use or changes in the performance set forth by the manufacturer or introduction of additional risks.

SERVICE CENTRE

The technical service centre is a supplier of repair, maintenance, installation and spare parts and accessories sales services for products, equipment and systems that are authorised by the manufacturer. The service centre is required to use original spare parts/accessories and has special equipment or product technical specifications, supplied by the manufacturer.

OPERATOR QUALIFICATION

Minimum level of competences the operator must have to perform the described operation.

NUMBER OF OPERATORS

Suitable number of operators to perform the described operation in an optimal manner. This figure is based on a careful analysis carried out by the manufacturer, so the use of a different number of operators might prevent the attainment of the required result or endanger the persons involved.

MAN-MACHINE INTERACTION

Any situation where an operator interacts with the machine in any of the operational phases in at any moment in the machine life span.

MACHINE - MACHINERY

The machine object of this operating manual.

PARTLY COMPLETED MACHINE

Assembly which is almost machinery but which cannot in itself perform a specific application. Partly completed machinery is only intended to be incorporated into or assembled with other machinery or other partly completed machinery or equipment, thereby forming machinery to which the Directive applies.

MACHINE STATE:

The machine state includes operation mode, e.g. automatic start, jog control, stop, etc., the condition of the safety devices present on the machine such as included protectors, excluded protectors, pressed emergency stop, type of isolation of the energy sources, etc.

FIXED GUARD

Guard kept in position (closed) or permanent (by sealing, etc.) or by means of fixing elements (screws, nuts, etc.) making its removal/opening impossible without the use of tools.

MOVABLE GUARD

Normally mechanically connected guard (e.g. by means of hinges or guides) to machine scaffolding or to a near-by fixed element and that can be opened without the aid of tools.

ADJUSTABLE GUARD

Fixed or movable guard that can be adjusted as only element or incorporates one or more adjustable parts. Adjustment remains permanent during a particular operation.

INTERLOCKED GUARD

Guard associated to an interlock device so that:

- the machine dangerous functions "enslaved" to the guard, cannot be performed until the guard is closed
- an order to stop is given, if guard is opened during performing of the machine dangerous functions
- guard closure allows executing the machine dangerous functions "enslaved" to the guard, but does not control its start-up.

INTERLOCKED GUARD WITH GUARD LOCKING

Guard associated to an interlock device and to a guard locking device so that:

- the machine dangerous functions "enslaved" to the guard, cannot be performed until the guard is closed and locked
- the guard remains closed and locked until risk of injuries deriving from the machine dangerous functions as ended
- closure and locking of guard allow executing the machine dangerous functions "enslaved" to the guard, but do not control its start-up.

PROTECTIVE DEVICE

Device (other than a guard) which reduces the risk, on its own or associated to a guard.

INTENDED USE

Use of the machine in compliance with the information provided in the operating instructions.

REASONABLY FORESEEABLE MISUSE

Use of the machine in a manner different from that stated in the operating instructions, but which may result from easily foreseeable human behaviour.

SAFETY COMPONENTS/DEVICE

It is a component used to assure a safety function and which fault or bad operation, jeopardises the health and/or safety of the exposed persons (e.g. lifting tool; fixed, movable, adjustable guard, etc., electric, electronic, optic, pneumatic, hydraulic device, that services a protection device, etc.).

RESIDUAL RISK

Danger that could not be eliminated or sufficiently reduced through design, against which the protections are not (or not fully) efficient. The manual contains these dangers and instructions and warnings on how to overcome it.

MANUFACTURER

The company: FROMM SLOVAKIA a.s. - Priemyselna 5885 - 90101 Malacky Slovakia.

CUSTOMER - EMPLOYER - USER

The company, including its managing director, where the machine in this operating manual, is used.

CHAP.2 GENERAL INFORMATION AND CHARACTERISTICS

2.1. TECHNICAL FEATURES

2.1.1. PURPOSE - AIM - CONSTRUCTIVE PARTS

Pallet wrapper FS360 is a machine designed and manufactured to wrap pallets using stretch film with a thickness up to 35 micron.

CYCLE AND OPERATION MODE OF MACHINE

Machine FS360 is suitable for the wrapping of palletized goods using film to protect or stabilize them. Wrapping modes vary depending on the setting most suitable to obtain the best protection and stabilization results and depend on the type of goods on the pallet.

SAFETY MEASURES

The machine is equipped with all the fixed and movable guards and protective devices necessary to guarantee personnel safety: operator and authorised service centre. In this case, during automatic cycle processing, the work area and the machine movements must be segregated with interlocked fixed and movable guards.

For tooling, loading/unloading, etc... operations it is not necessary, and therefore not possible, to suspend the protective devices to command movements of the machine with hold-to-run devices (enhanced safety conditions) with electrically sensitive (safety barrier) protective devices temporarily suspended in manual operating conditions.

FURTHER SPECIFICATIONS

The machine is stationary, i.e. is designed to be placed on stable ground that can withstand the weight of the machine and the pallet.

The machine is intended **solely for professional operators** and not for consumers.

MACHINE FUNCTIONS

The automatic functions, programming and operational sequence, are managed by a programmable logic controller and by electromechanical components; the machine main functions are displayed on control panel.

MACHINE UNITS

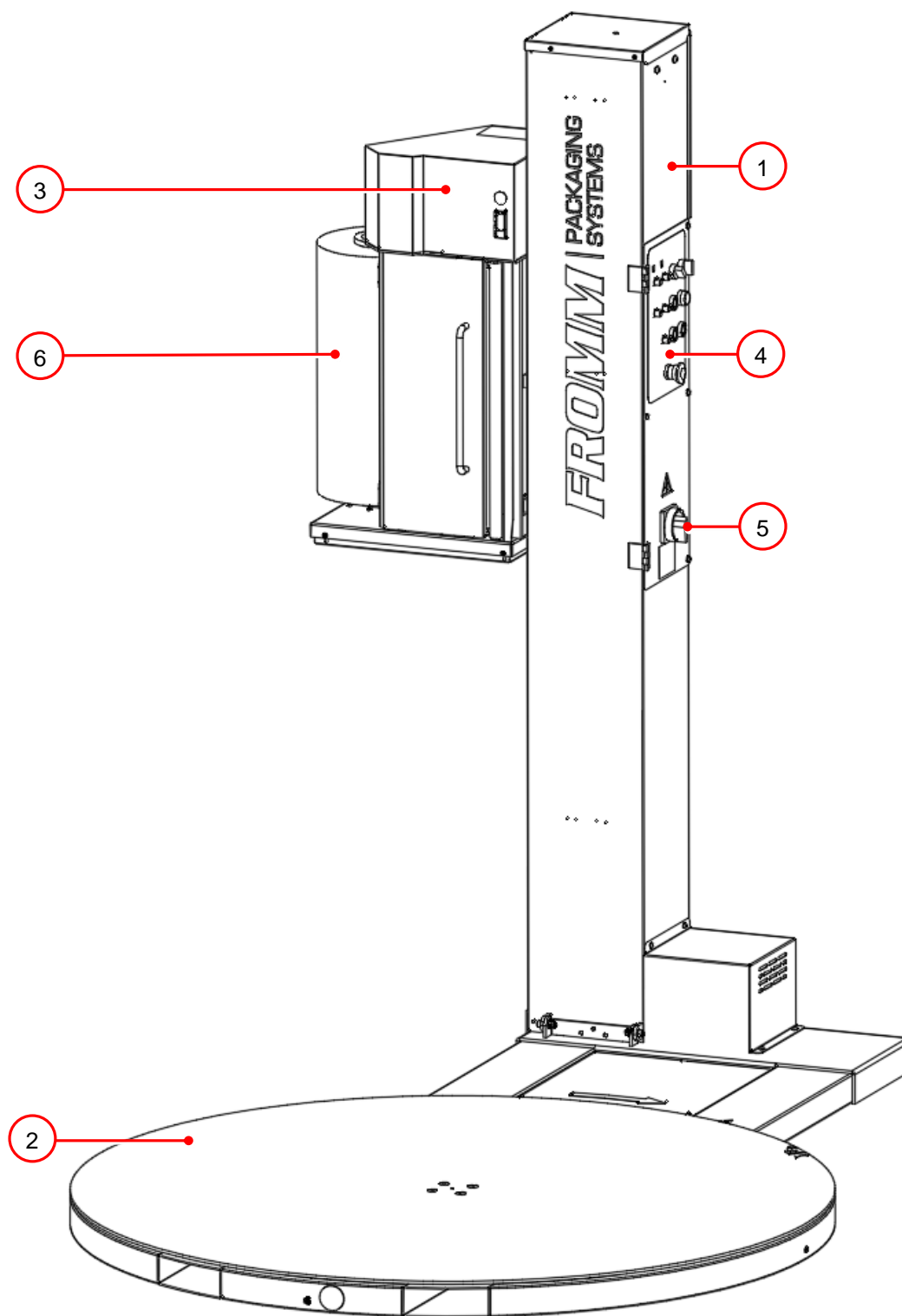

REF.	DESCRIPTION
1	Column
2	Table
3	Carriage
4	Operator panel
5	Main switch
6	Film reel

ELECTRICAL EQUIPMENT

The machine's electrical equipment consists of:

1. no. 1 section contained within the machine column featuring all the electrical components, similar to an electrical panel. The column is equipped with a side closure that can be opened to access electrical components. The column contains the electrical components of the command and control circuit, and direct start-up operation equipment of electrical motors. The electrical power supply isolator is found in bottom outer area of the operator panel.
2. a control panel located on the side of the column, out of the danger zone. The control panel contains a display showing some settings as well as the controls and adjustments to manage the machine's movements and logic. In addition, the panel contains control devices such as the START/STOP device, etc...
3. multiple sections with motors, devices and components distributed and wired onboard the machine (top part of the column, bottom part of the column, carriage containing the stretch unit, rotary table).

2.1.2. PERFORMANCE

The machine object of this operating manual, due to how it is conceived, designed and built:

1. If used in compliance with the safety requisites specified in **Chapter 4**
2. If used in compliance with the mode specifications under **chapter 6**
3. If regularly subjected to maintenance and cleaned as indicated in **chapter 7**

2.1.3. TECHNICAL AND CONSTRUCTIVE DATA OF SUPPLY

The main data characterising the machine are:

1. Film technical data

- | | |
|-------------------|------------|
| a. Film height | 500 mm |
| b. Film Type | stretch |
| c. Film thickness | up to 35µm |

2. Film reel characteristics

- | | |
|-------------------|------------------|
| a. Inner diameter | 76 mm |
| b. Outer diameter | 250 mm (maximum) |



Do not use films with a thickness other than what specified without first contacting the manufacturer.

2.2. PROCESSED PRODUCTS - HANDLED OR GENERATED

The products treated by the machine, object of this manual, **must consist of stretch film.**

2.3. EMISSION OF AIRBORNE NOISE

INFORMATION ON AIRBORNE NOISE EMISSION	FEATURES
A-weighted sound pressure levels emission at workstations	
Near the control panel	< 70 dB (A) ± 3 dB (A) of uncertainty

The values shown are emission levels and do not necessarily represent safe levels of exposure while on the job. Although emission levels and exposure levels are correlated, the correlation may not be used in a manner reliable in establishing whether further precautions are necessary or not. The factors influencing the level of current exposure of the operator include the characteristics of the work place, other sources of noise, etc., as well as the number of machines and other processes in the vicinity. The exposure level may also vary from country to country. In any case, this information does allow the machine user to better assess the degree of risk and danger.



The above-mentioned values are **those effectively measured on the machine in question.**



Sound data is measured using the methods defined in the harmonised standards and the most appropriate measuring code for the machine: EN 415-9:2009

2.4. SERVICE CONDITIONS

SERVICE CONDITION	LIMITS FOR THE USER
Method of installation	Indoor
Conditions of the support ground	Horizontal and smooth: errors in evenness and gradient within a 2% slope
Support surface features	Reinforced cement flooring or conform to the health and safety at work standards, in accordance with the applicable legislation
Load-bearing capacity of the floor	1500 kg / m²
Compression resistance classes of the ground for fastening the guards or protective devices	EN 206-1, latest edition, chart 7: class from C20/25 to C50/60
Minimum spaces around the machine:	<ul style="list-style-type: none"> • Reference CHAP.4
Maximum ambient air temperature	+40°C
Minimum ambient air temperature	+5°C
Work ambient temperature	+5 °C < T < +40 C
Transport and storage temperature	between -5°C and +50°C
Maximum altitude above sea level	1000m
Minimum requested lighting	500 lux
65% relative humidity at +25°C	
Relative humidity must not exceed 50% at the temperature of +40°C	
Equipment for machine installed indoors	
Machine unsuitable for use in contaminated atmospheres, e.g. dust, acid, corrosive gas, salt and similar	
Machine unsuitable for operating in environments with potentially explosive atmospheres classified as area 0 or area 1 or area 2 or area 20 or area 21 or area 22	
Machine inadequate to operate in environments with ionising and non-ionising radiations: e.g. microwaves, UV rays, laser, X-rays and similar	
Inadequate electrical equipment for machines or to operate in environments with vibrations and impacts: on the contrary, assemble it away from the appliance, provide anti-vibrating supports	
Pollution degrees for electrical equipment equal to 3 (THREE)	
Installation environment equal to two (2)	
As compliant with Standard EN 61000-6-1, it can be used in residential, commercial or light industry environments	
Intended for industrial process machinery direct/exclusive service	
Particular and additional provisions the machine is unsuitable for	<ol style="list-style-type: none"> 1. outdoor use 2. treatment of potentially explosive material 3. use in potentially explosive and/or flammable atmospheres 4. use with specific risks in processing certain materials 5. use in a mine 6. use in chillers 7. use at high temperature 8. use in corrosive environments 9. use in strong magnetic fields 10. use in conditions of radioactivity 11. use for loads, the nature of which may lead to a situation of risk (e.g. molten metal, acids/bases, particularly fragile loads, explosives) 12. use on ships and earthquake effect 13. use in contact with food substances 14. use in public areas 15. use of ground support for aeroplanes.

2.5. ELECTRICAL EQUIPMENT POWER SUPPLY

The main technical features for the machine in question, are reported below.

TECHNICAL FEATURE TYPE	MANUFACTURER WARRANTIES	LIMITS FOR THE USER
AC POWER SUPPLY		
Nature of current	1 phase + N + PE	
Full load value of current	See wiring diagram $\pm 10\%$	
Current nominal value	See wiring diagram $\pm 10\%$	
Use nominal voltage	Ue = AC 230 V	$\pm 10\%$
Frequency	50/60 Hz	$\pm 1\%$ continuously and $\pm 2\%$ for a short period
Presumed short circuit current in installation point	See wiring diagram	
Recommend power supply cable position		protected with sheath or duct
Power supply cable		H05 RNF 300/500
Phase conductors section used		1.5 mm ²
Neutral conductors' section used		1.5 mm ²
Section of the equipotential protective conductor used		1.5 mm ²
Harmonic distortion due to the sum of harmonics from second to fifth		must not exceed 10% of the effective total voltage value among active conductors
harmonic distortion due to the sum of harmonics from sixth to thirtieth		must not exceed 2% of the effective total voltage value among active conductors
Inverse phase component and zero phase component of the three-phase power supply voltage		Must not exceed 2% of the voltage direct phase component
Electric energy power supply interruption		Must not be interrupted or voltage must not drop to zero for more than 3 ms. More than 1 second must pass between two consecutive interruptions
Voltage dips		Any voltage dips must not exceed 20% of peak voltage and for more than one cycle. More than 1 second must pass between two consecutive voltage dips
NOMINAL VOLTAGE OF AUXILIARY CIRCUITS		
Voltage values	AC - DC 24V	
LIMITS OF OPERATION		
Short circuit interruption power of the protective device against over-currents	6kA	
Nominal jog voltage of power circuits	Uimp = 2500 V	
Nominal jog voltage of control circuits	Uimp = 500 V	
Nominal coincidence factor	1	
RECOMMENDED OVER-CURRENT PROTECTIVE DEVICE		
Nominal insulation voltage		Ui = > 300V
Nominal current		In = > 10 A
TYPE OF EARTHING OF THE POWER SUPPLY SYSTEMS		
MASS AND NEUTRAL		TN
EQUIPMENT'S PROTECTION RATING		
Electrical equipment's protection rating	machine onboard components minimum IP 32 casings minimum IP 32 control actuators minimum IP 32 motors minimum IP 32	
PROTECTION AGAINST DIRECT AND INDIRECT CONTACTS		
Protection against direct contacts	Protection through active parts isolation; Protection through barriers or casings (IP2X - IPXXB for all components)	
Protection against indirect contacts	Protection through use of protection circuit; Protection through automatic black-out	Considering a presumed short circuit current in the installation point of 6 symmetrical kA, provide a protective device for the power supply conductors with adequate breaking power
APPLIANCE INTERNAL DIVISION THROUGH BARRIER OR DIAPHRAGMS		
Segregation	no segregation (shape no. 1)	

TECHNICAL FEATURE TYPE	MANUFACTURER WARRANTIES	LIMITS FOR THE USER
VOLTAGE DROP FROM POWER SUPPLY INPUT POINT		
In normal operation conditions	Below 5% of nominal voltage	

2.6. NORMAL, IMPROPER, INCORRECT / FORBIDDEN / REASONABLY PREDICTABLE INCORRECT USE

The machine is designed to be handled:



by an operator trained and informed on residual risks, who deals with the command and control of the machine for its use and loading/unloading operations and, in general, of its running/production. He/she must be trained on the set-up of the machine push button panels and on all management and safety commands. He/she must also be informed and trained on handling the pieces, on the work methods and limits. The operator must work only with the safety devices enabled. He/she must also be instructed about how to handle and manage the processed pieces. The operator also performs **tooling** tasks for which no tools are required, or rather, operations that can be executed manually or with the tools made available by the machine manufacturer and is trained and informed on the residual risks but with the skills, on safety matters, of a prepared maintenance technician. He/she must have the instructions for the placement, the list of the equipment, of the positioning devices and piece locking. He/she must also be trained and especially informed on the tooling activities to be performed manually and on preparation of time schedules.

The operator's tasks and normal work areas are:

1. arrange the machine according to the production requirements and perform the switch-on procedure
2. set the production parameters on the operator panel
3. load the film reel
4. wrap the goods on the pallet using a stretch film.
5. check for and remove any film residues when dangerous mobile parts are still and powered off.
6. he is responsible for the work process and has the task of controlling the machine, by means of control actuators on the control panel
7. performance of checks (such as reading data on the control panel or instruments); these are easy to carry out in safe conditions and are clearly described in the use instruction manual
8. operate the machine, i.e. stopping and starting the machine in normal conditions, and stopping it in emergency conditions.



By 1 mechanical technician and one electrical technician, both trained and informed on the residual risks, but having the safety skills of maintenance technicians to whom machine maintenance is entrusted. He/she must perform all maintenance works, including those within the machine's dangerous areas with movable guards open, with movements not powered and safely stopped.



He/she must be a mechanical, electrical expert, etc. and must be able to evaluate assigned work and recognise potential hazards based of his/her own background, knowledge and professional experience. The personnel must be **skilled rather than simply aware**, i.e. they must be high school or university graduates with specific know-how concerning the machine and its equipment and the relative standards and legislation, and must also have specific technical knowledge and training.

The maintenance technician can also access the E.P. with powered equipment. He/she must also be trained and especially instructed on activities to be performed with tools.



authorised service centre mechanical and electrical technicians, both trained and informed on the residual risks, but having the safety skills of maintenance technicians to whom machine maintenance is entrusted. He/she must perform all maintenance works, including those within the machine's dangerous areas with movable guards open, with movements not powered and safely stopped. The **authorised service centre** personnel can also access the E.P. with powered equipment.

NORMAL USE



In conditions of **NORMAL** and reasonably foreseeable USE, the machine may only be used:

1. to process products, according to operation logic defined in chapter 6 and in this chapter. Using the machine for different processing operations to those in this manual is considered improper and strictly forbidden
2. with use of the described products (and materials) having the dimensions in this chapter.

IMPROPER USE



The machine must not be used **IN AN IMPROPER MANNER**. In particular:

1. it cannot be operated with different parameters to those set out in the technical features table in this chapter and with products and/or materials having different features to those previously indicated
2. every machine use different to that indicated in this manual, is to be considered improper. The manufacturer will, therefore, decline every liability
3. the user is responsible for the damages due to non-compliance with the working conditions agreed during order confirmation and technical specification.

INCORRECT/FORBIDDEN/REASONABLY PREDICTABLE INCORRECT USE



The machine must not be used in an **INCORRECT / PROHIBITED / REASONABLY FORESEEABLE INCORRECT MANNER**. In particular:

1. it is forbidden to use flammable, corrosive or toxic substances for cleaning
2. it is forbidden to smoke or use naked flames appliances and handle incandescent materials, unless adequate safety measures are taken
3. it is forbidden to activate or adjust control and locking devices such as knobs or similar, during machine operation and if not authorised
4. it is forbidden to hand objects or weights to the machine
5. it is forbidden to use open, incorrectly fixed or removed protection guards
6. the use without the user having adopted all provisions to eliminate the residual risks indicated in this operating manual, is forbidden
7. the use in different operations to those indicated in this operating manual is forbidden (see chapter 6)
8. it is forbidden to allow untrained personnel to use the machine
9. it is forbidden to use the machine in critical stability conditions, meaning:
 - positioned on non-horizontal, not smooth grounds and having inadequate capacity to that provided in this manual
 - outdoors or on sites without doors and windows
10. **It is forbidden to perform any repair or adjustment on moving parts**
11. do not perform any intervention while the machine is in operation, perform them only after stopping it and placing it in safety conditions.
12. do not tamper with, elude, remove or bypass the safety devices installed on the machine
13. do not modify the machine's manufacturing and functional characteristics in any way
14. do not use the machine if scheduled maintenance operations have not been regularly performed
15. do not keep using the machine if you encounter an anomaly
16. do not clean or wash the machine with aggressive products to avoid damaging the components
17. do not use the machine with purposes and modes not envisaged by the Manufacturer
18. do not use the machine as a support surface for work activities (e.g. as a workbench).

GENERAL INFORMATION



This manual lists and describes improper and forbidden uses that the authorised personnel must avoid:

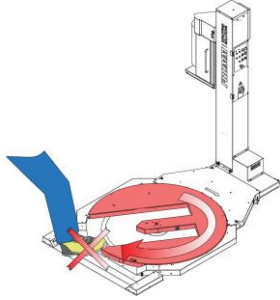
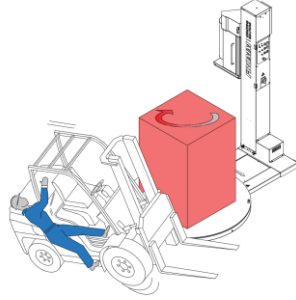
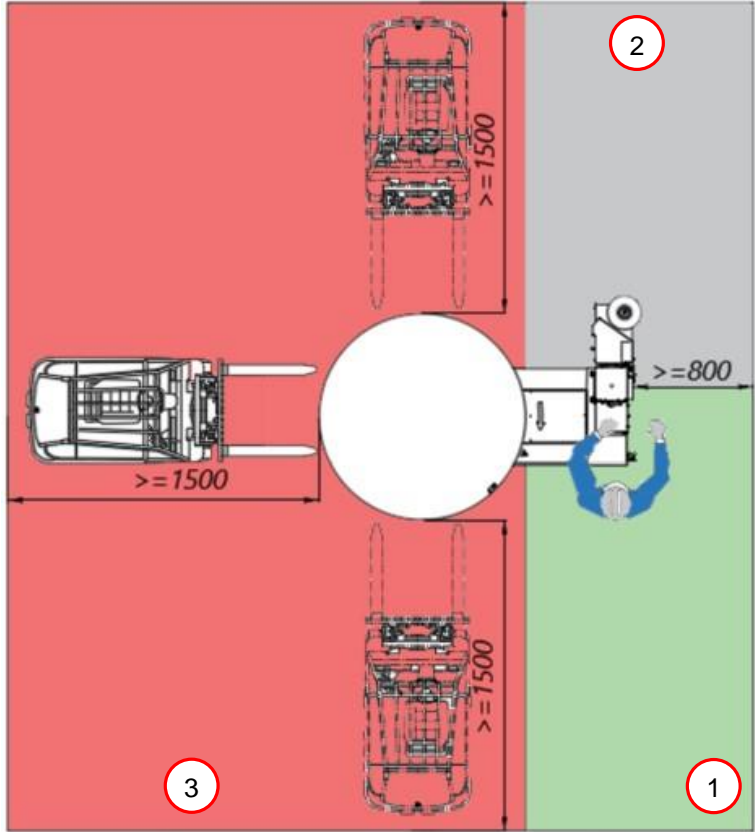

<p>HITTING AND SLIPPING: Do not climb on the machine while in operation.</p>	
<p>HITTING AND SLIPPING: Do not approach the machine elements when in operation.</p>	
<p>CRUSHING OF UPPER LIMBS: Do not put your arms into the moving elements.</p>	
<p>CRUSHING OF THE BODY: Do not stand in the machine's operating area.</p>	

<p>CRUSHING OF UPPER/LOWER LIMBS: Do not put your arms into the moving elements.</p>	
<p>HITTING: Do not approach the machine elements with the lifting device when in operation.</p>	
<p>FALLING OR OBJECT PROJECTIONS: When using the machine, set parameters (Table Speed in particular) compatible with the stability of the goods to be wrapped.</p>	

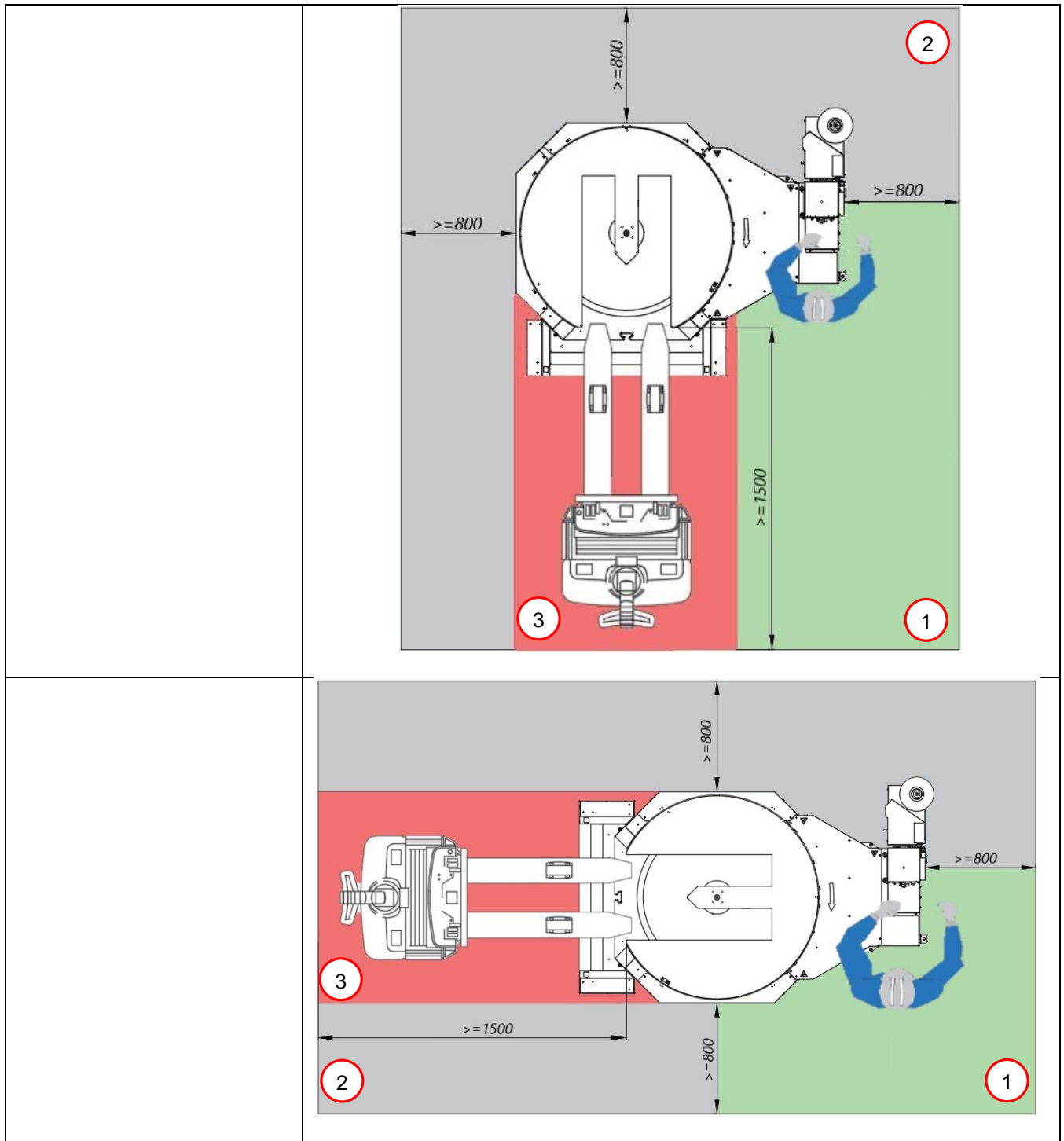

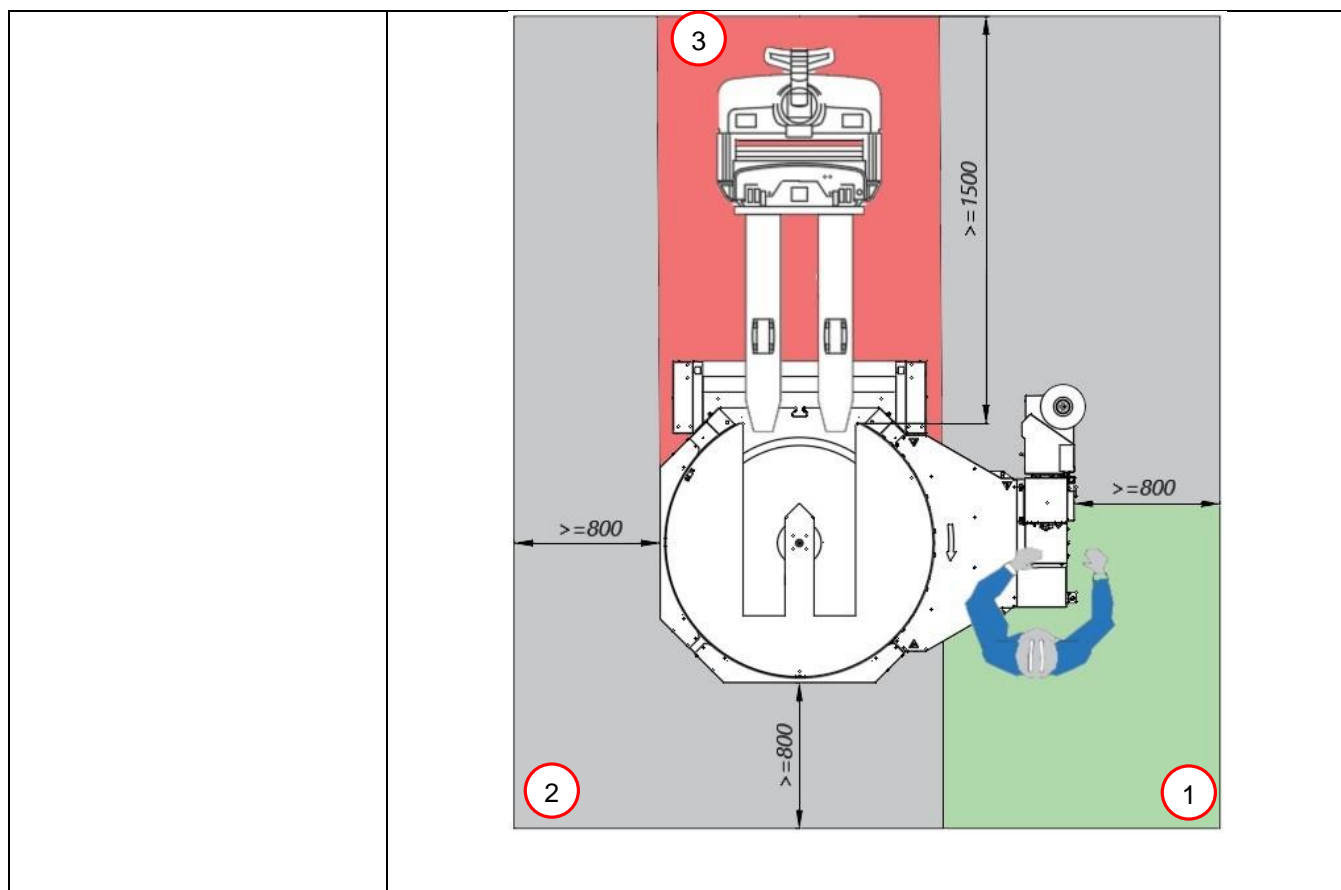

- 1 Operator Area
- 2 Perimeter Area
- 3 Loading / Unloading Area



The manufacturer cannot be considered liable for any fault caused by the unreasonable, improper and/or wrong use.

The user is any case responsible for any damage resulting from failure to comply with the specified terms of use. Contact the manufacturer's technical department if in doubt.

The user is responsible for supplying the operators with personal protective means and informing the users on the admitted uses.

CHAP.3 CONSISTENCY OF SUPPLY

3.1. MACHINE IDENTIFICATION

An identification label with the following information is installed on the rear part of the machine. Should the label be damaged, contact the manufacturer immediately.

FROMM SLOVAKIA a.s. Priemyselna 5885,90101 Malacky Slovakia Tel. +421347723824 - +42134 7723845 Fax +42134772 3851		
MACHINE DESIGNATION	PALLET WRAPPING MACHINE	
MODEL	FS360	
SERIAL NUMBER	
MACHINE MASS kg	
POWER SUPPLY	230 V 50/60 Hz	
SHORT CIRCUIT CURRENT	6 kA rms A.R. 230V	
WIRING DIAGRAM NUMBER	
POWER USED	1 kW	
PROTECTION FUSE	10 Amp	
YEAR OF MANUFACTURE	

3.2. CERTIFICATION

Directive 2006/42/EC specifies the minimum conditions with which the machine can be placed on the EU market.

The above Directive describes all machines that can be sold and commissioned, only if they do not jeopardise the health and safety of persons, domestic animals and goods.

The machine is not in the category of machines on the list in the Directive's attachment IV. Before placing on the market, FROMM carried out all tests and checks provided by the standards of reference, including risk analysis, to verify the punctual respect with the essential health and safety requirements provided by the Directive, to certify machine conformity with the same. The construction technical file collecting all essential project data and machine safety features, is processed in compliance with attachment VII of Directive 2006/42/EC, **kept at FROMM ITALIANA SRL** and available for the supervising bodies' verification, if reasonably requested, as provided by the relative legal dispositions in force.

Having, by means of the above analysis, verified that the machine is designed and built in compliance with the dispositions of Directive 2006/42/EC and that the same machine can be safely used in the service conditions under this manual, FROMM places the machine on the market provided and accompanied by:

1. CE Marking
2. CE Declaration of conformity
3. Use instructions manual (User manual).

3.3. WARRANTY CONDITIONS

FROMM HOLDING A.G. undertakes to repair or replace free of charge any part that may result defective within twelve months from the date of sale within the limitations described below. In order to take advantage of the warranty in case of a defect, the user must promptly report the problem and communicate the machine's serial number. FROMM HOLDING A.G. shall decide whether to replace the defective part or require it to be sent back for checks and/or repairs as it deems fit. By replacing or repairing the defective part, FROMM HOLDING A.G. fully fulfils its warranty obligations and is released from all responsibility and obligation concerning transport, travel and board expenses for technicians and assemblers. FROMM HOLDING A.G. shall not be liable for any loss deriving from non-production or for damages to people or things caused by a breakdown or forced suspension of the machine under warranty.

THE FOLLOWING ARE NOT UNDER WARRANTY: - Transport damages - Damages caused by erroneous installation - Improper use of the machine or negligence - Tampering or repairs performed by unauthorised personnel - Lack of maintenance - Parts subject to normal wear. For purchased components and parts, FROMM HOLDING A.G. applies the same warranty terms obtained from the suppliers of said components and/or parts. FROMM HOLDING A.G. does not guarantee the compliance of the machines with applicable regulations outside of the European Union. Bringing the machine into compliance with the regulations of the Nation where it is installed will be the responsibility of the user, who will also be responsible for any modification made releasing FROMM HOLDING A.G. from any obligation and/or responsibility regarding any claim made by third parties due to the non-observance of the regulations in question.

3.4. DECLARATION OF CONFORMITY

2006/42/EC (Annex II part A)

The undersigned, representing the manufacturer

<i>Manufacturer</i>	FROMM SLOVAKIA a.s.
<i>Address</i>	Priemyselna 5885 - 90101 Malacky Slovakia

as employed the person authorised to draft and keep the technical dossier

<i>Name</i>	FROMM ITALIANA s.r.l.
<i>Address</i>	Viale del Lavoro, 21 37013 Caprino Veronese (VR) ITALIA

The Manufacturer declares that the machine

<i>Generic/trade name</i>	PALLET WRAPPING MACHINE
<i>Function</i>	PALLET WRAPPING
<i>Model</i>	FS360
<i>Serial number</i>	SEE LABEL ON THE MACHINE
<i>Year of manufacture</i>

conforms to all the provisions of the following community directives (and all applicable amendments)

2006/42/EC - Machinery Directive

2014/30/EU - Electromagnetic Compatibility Directive

Pursuant to the Electromagnetic Compatibility Directive, the following harmonised standards have been applied:
EN 61000-6-2:2005 Electromagnetic compatibility (EMC) — Part 6-2: Generic standards - Immunity for industrial environments

EN 61000-6-4:2007+A1:2011 Electromagnetic compatibility (EMC) — Part 6-4: Generic standards - Emission for industrial environments.

EN 415-6: 2013 Safety of packaging machines: Part 6 Pallet wrapping machines.

FROMM Holding AG
Hinterbergstrasse 26
CH - 6330 Cham Switzerland

01/04/2020
R.Fromm President



CHAP.4 SAFETY INSTRUCTIONS

4.1. INTRODUCTION



ALWAYS RESPECT THE SAFETY PROVISIONS.

FAILURE TO APPLY THE SAFETY STANDARDS AND PROCEDURES CAN BE DANGEROUS, WITH THE RISK OF INJURY TO PERSONNEL AND DAMAGE TO THE MACHINE.

The safety instructions in this operating manual are generic and do not extend to all the situations that may arise, even if based on experience.

These instructions integrate and do not replace the constant application of the basic safety rules by the machine customer, known to those working in the specific field.

We recommend respecting the safety and prevention standards already used where the machine will be used.



The residual risks on the machine, despite the correct application of the design and safety standards, are highlighted in chapter 4; the modes to be applied by the customer to reduce and/or eliminate the highlighted residual risks are also indicated.

Chapter 4 shows the type of plates present on the machine and those that must be applied on it or near it.

The machine supplied by our company must be integrated and used (operation and maintenance), by the Customer and/or the end user, in compliance with:

1. all personal behaviour and installation in the environment rules established by the applicable laws and/or standards; particularly with regard to fixed system upstream of the supplied machine and its connection/operation
2. all further operating instructions and warnings part of the technical/graphic documentation annexed to the machine itself.

The machine must be **installed, protected, used, serviced, and dismantled** (following decommissioning) in such a way as to avoid hazards (as far as is reasonably possible) for persons, property or animals. Action must also be taken to ensure the necessary maintenance work is carried out.

4.2. OBLIGATIONS AND DUTIES

4.2.1. PLANT MANAGEMENT OBLIGATIONS

Within their tasks and competences, the plant managers supervising the working activity, must:

1. implement the foreseen safety measures
2. inform the operators on the specific risks to which they are exposed and on the essential prevention standards
3. dispose and expect that the individual operators observe the safety standards and use the PPE made available to them
4. have more than one operator work on said product, simultaneously.

Following machine commissioning at your plant, it is also specified that the same is subject to that provided/prescribed by Directive 2009/104/EC and subsequent modifications.

4.2.2. PERSONNEL MAIN REQUIREMENTS

The personnel who interact with the supplied machine must:

1. have read and understood all the safety prescriptions given in the Operating Manual
2. be in normal psycho-physical conditions
3. have been previously informed and trained on:
 - 3.1. the dangers of injuries or other damages that may derive from direct or indirect contacts
 - 3.2. the dangers of non-electrical nature that may derive from any present electrical material
 - 3.3. the dangers of injuries or other damages due to the residual risks reported in this operating manual
4. have (or acquire by means of adequate training and educating), the following requirements:
 - 4.1. general and technical culture of sufficient level to understand this Operating manual to use and correctly understand any attached electrical diagram and all technical drawings
 - 4.2. knowledge of the main technological, accident-prevention and hygiene, health and safety standards
 - 4.3. overall knowledge of the machine and of the electrical equipment that may be present
 - 4.4. know how to behave in an emergency
 - 4.5. know where to find and how to correctly use the PPE, if the manufacturer indications prescribe it or if the collective protections are insufficient
5. immediately report safety and protective devices and means deficiencies and any other arisen danger conditions to the employer and immediately make every effort within their competences and possibilities, to eliminate or reduce said deficiencies or dangers
6. do not remove or modify the safety and protective devices and means without authorisation
7. do not perform operations or manoeuvres, of own initiative, that are not of competence and might jeopardise own and others safety
8. do not wear rings, wrist watches, jewellery, torn clothing, scarves, ties or any other loose clothing or accessory that might be source of risk; tighten sleeves properly around the wrists and always keep hair tied back
9. are of adult age
10. are physically and psychically suitable to perform particularly difficult technical work
11. have been adequately trained on using and servicing the machine
12. have been judged suitable to perform the entrusted task by the employer
13. are able to understand and interpret the operator manual and safety prescriptions
14. know the emergency procedures and their implementing
15. has the ability of activating the specific type of equipment
16. are familiar with the specific rules of the case
17. have understood the operational procedures defined by the machine manufacturer
18. take care of one's own health and safety and that of others present in the workplace, on whom the effects of his actions or omissions fall, in compliance with his training, instructions and means supplied by the employer
19. contribute, together with the employer, managers and supervisors to fulfil the obligations provided to safeguard health and safety at the workplace
20. observe the regulations and instructions issued by the employer, managers and supervisors for the purposes of collective and individual protection

21. correctly use work equipment, safety and protective devices made available to them
22. participate in training programs organised by the employer
23. undergo health inspections provided by the present legislative decree or, in any case, ordered by the company physician.



Personnel in charge of **installation, connection, maintenance, re-installation and reuse, troubleshooting, cleaning and disinfecting, demolishing and dismantling, except where otherwise specified**, must be **experienced**, trained on safety and informed on the residual risks (see chapter 4), having the safety competences of maintenance technicians.



All specific skills and tasks as well as the dangerous areas, in which the operator and maintenance technician are supposed to perform the functions of this manual, are respectively given in Chapter 6 (for the operator), and in chapter 7 (for the maintenance technician).



Such expert personnel must be capable of assessing the work assigned to them, and recognising any possible hazards on the basis of their training, knowledge, and professional experience and their knowledge of the machines in question, the relative equipment and the applicable standards and legislation; they must also be in possession of an adequate professional qualification concerning the machines in question. Must be trained on safety and informed of the residual risks under chapter 4.



The personnel must be **skilled rather than simply aware**, i.e. they must be high school or university graduates with specific know-how concerning the machine and its equipment and the relative standards and legislation, and must also have specific technical knowledge and training.

In addition **to performing all maintenance work**, these persons must also be able to support the operator in certain cases for tooling procedures. The maintenance technician can also access the E.P. with powered equipment.

The presence of other persons except the operator, in the areas around the machine during processing, is not admitted **for safety purposes**.

The only exception to this rule is the presence of maintenance technicians expressly authorised by the person in charge of production.

The person responsible for adjusting/tuning, using and servicing the machine must immediately suspend activities and inform the employer or department foreman or person in charge if any defects or operating anomalies are noted.

If the user does not have any expert or skilled personnel, the activities in question must be outsourced to a suitable qualified external company such as, for example, the supplier.

4.3. ENVIRONMENTS, WORK AND TRANSITING PLACES

The work environment meets the requirements of Directive 89/654/EEC. There must not be any foreign objects in the work area. The lighting devices must be checked from time to time and kept in efficient working order.

In compliance with Directive 89/391/EEC concerning the implementation of measures aimed at improving the health and safety of workers during working hours, **the employer** must take steps to eliminate or reduce the residual risks as envisaged by the terms of this manual.

FLOORS AND PASSAGES AROUND THE MACHINE

The floors in the work environments and passageways around the machine, must not have any holes or dangerous protrusions and must be in good condition to ensure safe movement and transit of people and means of transport. There must not be material on the floors and in the passageways that could obstruct normal circulation. Any fixed or mobile obstacles that present a danger to workers or vehicles and which, for technical reasons, cannot be removed from the transit areas must be clearly marked.

The employer must make sure the area around the machine is sufficiently ventilated and equipped with vents and safety devices.

DEFENCE AGAINST FIRES

Suitable measures must be taken in all companies or for specific processes, to prevent fires and protect the safety of workers in the event of fire.

In companies or specific processes where specific fire dangers exist:

1. it is forbidden to smoke
2. it is forbidden to use naked flames and to use incandescent materials unless suitable safety measures are taken
3. extinguishing devices must be made available in relation to the particular conditions in which they can be used, including portable emergency extinguishers
4. this equipment must be kept in efficient working order and be checked at least once every six months by experienced personnel
5. the easy and quick departure of workers from dangerous places must be assured, if required
6. water must not be used to put out fires when the material one would come into contact with, may react, significantly increasing temperature or emitting flammable or harmful gases. Unless using nebulised water, like water other conductive substances must not be used near powered conductors, machines and electrical appliances.

The above prohibitions must be made known to personnel using signs.

NOISE

The machine in this operating manual produces an airborne noise indicated in chapter 2, in the main work and control areas of the machine.

Even though the machine itself is not particularly noisy, there are certain factors that may increase the possible risks: the duration of exposure to the noise, the characteristics of the buildings, the noise level from other machines nearby, etc.

Therefore, the employer must adopt the following provisions:

1. Limit the time of exposure providing work shifts
2. provide operators with PPE (earmuffs) and train them on their correct use
3. subject the workers to periodical medical check-ups.

LIGHTING

The room in which the machine is installed must be sufficiently well lit for carrying out a visual inspection of the machine and the pictograms on it. In the case of installations that are all or partly underground, suitable lighting must be provided such as a portable light that conforms to the applicable regulations in force. The light must not be so bright as to cause glare or, in any case, cause visual irritation for the safety manager or maintenance technician.

CLIMATIC CONDITIONS

Similarly to that reported for noise and lighting, also check the work environments climate is “bearable”.

The machine, the object of this operating manual, is suitable for operation in the climatic conditions defined in chapter 2, where its technical specifications are indicated.

GENERAL CONDITIONS OF THE ENVIRONMENT WHERE THE MACHINE IS USED

1. The work environment meets the requirements of Directive 89/654/EEC.
2. The lighting devices must be checked from time to time and kept in efficient working order.
3. There must not be any foreign objects in the work area.
4. The tubes and cables must be protected and must not constitute an obstacle.
5. The environmental and working conditions must not constitute an obstacle to access to any of the controls like the emergency stop button.

4.4. GENERAL MACHINE PROTECTION REGULATIONS

TEMPORARY REMOVAL OF SAFETY PROTECTIONS AND DEVICES

The machines safety devices and protections must not be removed if not for work purposes.

When they do need to be removed, **it is important to immediately adopt suitable measures to highlight and minimise the consequential hazards.**

The safety protection or device must be immediately put back into place once the reasons for their temporary removal have ceased.

PROHIBITION TO CLEAN, OIL OR GREASE MOVING PARTS

Unless required for specific technical needs, in which case suitable means must be used to avoid every danger, it is forbidden to manually clean, oil or grease the machine moving parts and elements.

The workers must be informed by means of clearly visible signs.

PROHIBITION TO REPAIR OR ADJUST MOVING PARTS

It is forbidden to perform any repair or adjustment on moving parts.

Adequate precautions must be taken to protect the worker's safety, if these operations must be carried out during movement.

The workers must be informed by means of clearly visible signs.

4.5. MOVING STRUCTURES



Always ensure the movement area is clear of personnel or objects that might be a danger, before moving the structures.



Do not move any structure if lighting and/or visibility is scarce, until a senior member has ascertained freedom of movement within the work area; always visually ascertain the work area is free, do not give it for granted.

Electrically and mechanically lock all mobile parts of a structure or equipment that must be transported.

4.6. LIFTING MEANS



Ensure the hooking and lifting pins of a lifting mean used to handle the machine, are correctly arranged. Take the necessary precautions to prevent dangerous overloads due to acceleration, deceleration or impacts.



Ensure a load is properly tightened and correctly balanced in the lifting device, before lifting it.

**DO NOT LIFT LOADS ABOVE PERSONS;
LOWER THE LOAD OR CLEAR THE AREA
FOR MOVEMENT FROM PERSONS.**

Ensure the slings used for lifting are in good conditions and suitable for the type of work to be carried out.

Ensure the cranes safety workload is greater than the weight to be lifted.

4.7. PERSONAL PROTECTIVE EQUIPMENT AND FIRST AID

Use PPE in compliance with Directive 2009/104/EC and subsequent amendments and updates.

4.8. INDICATIONS ON RESIDUAL RISKS PRESENT

GENERAL INFORMATION



This manual **lists and describes the residual risks** that could not be eliminated during the design phase and which persist on the machine.



Suitable instructions are given **for each risk**, and the user must observe them in order to avoid any danger for the machine operator and maintenance technicians.



The presence of other persons except the operator is not admitted in the areas around the machine during processing **for safety purposes**.



After considering the possible risks relating to machine use and maintenance, all the necessary solutions have been adopted **to eliminate such risks and restrict the level of danger for exposed persons**.

However, the following possible residual risks remain on the machine, that can be eliminated or reduced with the indicated precautions.



In compliance with Directive 89/391/EEC and subsequent amendments and updates, on implementing the measures aimed at improving the health and safety of workers during work, **the employer** must eliminate or reduce the residue risks indicated in this manual.



The employer must train personnel on accident risks, safety devices and general accident-prevention rules provided by the community directives and legislation of country where machine is installed.

This requirement is the responsibility of the user, as well as to ensure the given instructions are adequately acknowledged.



The employer is responsible for training operators and maintenance technicians by means of training course and eventual collaboration with the machine manufacturer, so the same are adequately trained on risks in general and on the residual risks indicated herein.



Therefore, **use, maintenance and cleaning** must be entrusted to trained and competent personnel.

It is the responsibility of the employer to ensure that the instructions are respected.

The presence of other persons except the operator, in the areas around the machine **during processing**, is not admitted **for safety purposes**.

The only exception to this rule is the presence of maintenance technicians expressly authorised by the person in charge of production.

When necessary, **the user is also responsible for:**

1. arranging a training course, even in collaboration with the machine manufacturer, to ensure **the operators and maintenance technicians** are adequately trained on the general risks and residual risks specified in this manual
2. **using personal protective equipment** in compliance with the indications of Directive 2009/104/EC and subsequent amendments and updates.

USING THE MACHINE



The machine must be used exclusively for the purpose for which it is expressly designed, as indicated in chapter 2.



Only personnel having attended specific use and safety course and after having carefully read this manual, can use the machine.

In addition to being adequately instructed and trained to work with caution and to pay attention to the notices located on the machine, the machine operator **must always pay the utmost attention during normal machine use, and must comply with the prescribed methods of use.**

PPE to be used:

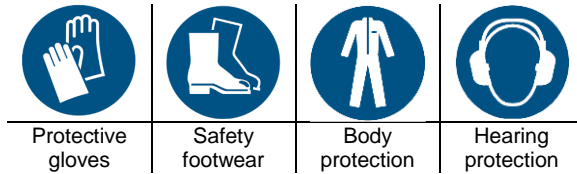

RESIDUAL RISK FOR INTERVENTIONS REQUIRING MANUAL OPERATIONS



Even if the indications in this manual are respected, manual operations on the machine, or in its moving parts, loading/unloading of products or handling of parts in general, are manual operations entailing a residual risk **mainly due to impacts, crushing, dragging, streaking or abrasion.**



There is the further residual risk during **maintenance, cleaning and manual operations that may cause the falling of parts or components** of impact, abrasion, cut, sting and friction due also to the need of performing manual interventions on the machine.



These operations require significant attention by the workers; the person in charge of operations must adequately inform personnel on these residual risks.



Therefore, whenever manual operations are carried out, in addition to being trained and **complying with the use methods provided for**, the maintenance technician **must use protective devices for the head (if there is a danger of elements falling from a height), hands, feet, as well as adequate work clothes, such as: cut-resistant gloves, non-slip, steel-toe footwear, resistant and suitable for the particular nature of the risk.**

PPE to be used:



RESIDUAL RISK DUE TO THE OPENING OF INTERLOCKED MOVABLE GUARDS, REMOVAL OF FIXED GUARDS, INTERVENTIONS ON BROKEN/WORN PARTS



The operator must never attempt opening a mobile guard or removing a fixed guard, during processing.



A residual risk during **tooling, maintenance, cleaning** and **during all further manual operations** entailing introducing hands or other body parts in the machine danger zones, remain with the movable guards opened, particularly due to:



- a. **impacts with the machine constructive parts or with the key activating the interlock safety micro switches assembled inside the mobile guards,**
- b. **friction and/or abrasion with machine rough parts,**
- c. **slipping or falling.**

These operations require significant attention by the workers; the person in charge of operations must adequately inform personnel on these residual risks.

In addition, maintenance technicians **must also be trained on carrying out manual operations with open guards or temporarily excluded safety devices**, instructed on the consequent risks and authorised by a responsible person.

If the safety devices must be temporarily suspended during routine and extraordinary maintenance, **measures that highlight and reduce the resulting danger to a minimum, must be taken immediately.**

The safety protection or device must be immediately put back into place once the reasons for their temporary removal have ceased.

PPE to be used:



Eye protection



Protective gloves



Safety footwear



Body protection

RESIDUAL RISK DUE TO THE PRESENCE OF CUTTING ELEMENTS



A residual risk both for the operator and for the maintenance technician **due to possible contact with film cutting elements**, because of the presence of blades.



The operator and maintenance technician must operate with caution, respecting the indications on the affixed labels and in this manual and use the provided PPE



Therefore, **in addition to complying with the intended methods for use**, both the operator and the maintenance technician must comply with the allowed and prohibited uses stated in chapter2 and in the suitable signs affixed on the machine, wear **appropriate protective garments to prevent contact with parts entailing a cutting hazard and if performing short jobs during which protections cannot be used.**

PPE to be used:



Protective gloves

RESIDUAL RISK DUE TO ACCUMULATED GRAVITATIONAL ENERGY



Residual risk when the kinematic chain is removed because of the **gravitational energy remaining in the goods movement system.**



Before disassembling the elements of the kinematic chain, halt the movement system.

PPE to be used:

Eye protection	Protective gloves	Safety footwear	Body protection

RESIDUAL RISK DUE TO NOISE



As per the run experimental tests, the machine produces **A-weighted equivalent continuous sound pressure level of (see chapter 2).**



In addition to being adequately trained and informed, during machine operation and maintenance interventions, the operator and maintenance technician **must always use appropriate hearing protection, like earmuffs or plugs or similar personal hearing protections**, to avoid dangers to the ears due to piercing or persistent noises.



PPE to be used:



Hearing protection

RESIDUAL RISK



there is a residual risk of slipping,



therefore all operators must use non-slip footwear that is resistant and suitable to the nature of the risk.



PPE to be used:

Safety footwear

RESIDUAL RISK DUE TO HITTING, TRIPPING AND/OR FALLING



Residual risk due to **hitting or tripping and falling** caused by the presence of horizontal structures at the level of the surface of reference (walking surface) near the access to the machine's internal area, during the access to the machine's internal area, with mobile guards open.



Said risk can also be present in case **material used to wrap the pallets or pallets themselves are found on the walking surface.**



Operators must, therefore, carefully operate and access the internal part of the machine with the mobile guards open with the maximum attention avoiding contact with said parts.

Therefore the operator and maintenance technician **must always make use of appropriate feet protection devices, such as non-slip footwear, resistant and suitable for the particular nature of the risk.**



PPE to be used:



Protective gloves



Safety footwear



Body protection



Hard hat

RESIDUAL RISK DUE TO HITTING THE HEAD



Residual risk due to the **possibility of hitting the head** caused by the presence of horizontal structures at a height below 2100 mm.



The operator must, therefore, carefully operate and access the internal parts of the machine with the maximum attention avoiding contact with said parts.

Furthermore, in said circumstances, **he must always use appropriate head protective equipment (helmet).**



PPE to be used:



Hard hat

RESIDUAL RISK DUE TO CRUSHING DURING PALLET HANDLING



Residual risk for both the operator and maintenance technician **due to the possible crushing of fingers and upper limbs** during the manual and motorised handling of pallets in the loading/unloading area.



Before approaching the machine, wait for all parts to stop.



Therefore, both the operator and the maintenance technician, **besides following the required operating procedures** must observe the permitted usage and prohibitions provided both in chapter 2 and in the designated signs hung on the machine and wear **protective clothing to limit the effects of crushing**.

PPE to be used:



Protective gloves



Safety footwear



Body protection

RESIDUAL RISK DUE TO FAULTY PLANT LIGHTING



As specified in chapter no. 2, plant lighting in working areas **must not be lower than 500 lux**.



A residual risk arises for the operator and maintenance technician - who would be forced to work with insufficient lighting - if the plant lights were to fail during normal work or cleaning, and during maintenance operations.



If so, **immediately interrupt processing and warn the plant maintenance service, in order to replace faulty lamp(s)**.



Any intervention can only be performed once adequate lighting has been restored.

PPE to be used:



Eye protection



Protective gloves



Safety footwear



Body protection



Hard hat

RESIDUAL RISK DUE THE SUBSTANCES USED IN THE MACHINE, PRODUCTS HANDLED AND ELECTRICAL EQUIPMENT CATCHING FIRE



To avoid dangers deriving from a fire:
 a. of the substances used in the machine
 b. against the residual risk due to a fire developing.



the employer must not only provide adequate training and information for the machine operator and maintenance technician, **but must also guarantee permanent fire prevention/fighting systems close to the machine command station.** These systems must be suitable for the type of material which may catch fire.



PPE to be used:



Eye protection



Protective gloves



Safety footwear



Body protection

RESIDUAL RISK DUE TO THE NATURE OF THE CLEANING, LUBRICATION PRODUCTS USED



Residual risk **caused by the nature and chemical composition of the cleaning and lubrication products used** during cleaning operations.



PPE to be used:



Eye protection



Protective gloves



Safety footwear



Body protection



RESIDUAL RISKS DUE TO DANGER OF ELECTROCUTION



By opening the main isolation device of the electric power supply, a residual risk is present for the electrical maintenance technician, in the drive DC intermediate circuits when the fixed protections guaranteeing a protection rating of IP 2X are open, **due to the presence of voltage higher than 60V for more than 5 seconds after black-out.**



The maintenance technicians must, therefore, carefully operate respecting the indications on the labels found near said components and **wait at least 5 minutes** after black-out, **opening the main isolation device of the electric power supply**, before intervening in the drive DC intermediate circuits.

Said persons must also follow the maintenance technicians own safety standards.

PPE to be used:



Eye protection



Protective gloves



Safety footwear



Body protection

RESIDUAL RISK DUE TO DANGER OF ELECTROCUTION



If required and necessary to intervene inside powered electrical panels, junction boxes and electrical components and/or with protections removed, to carry out checks, maintenance and operation tests, there is a residual risk for the electrical maintenance technician.



The maintenance technicians must, therefore, carefully operate respecting the indications on the labels found near said components.

It is compulsory for specialised and authorised “electrical technicians” only to access inside said areas, scrupulously respecting all safety standards concerning electrical plant design.

Not only must personnel carrying out said interventions be trained on electrical risks, but:

- must have an in-depth knowledge of all other safety problems relating to the machine in question
- must be specifically authorised by the Employer, to intervene on powered electrical equipment.

With regards the regulations for interventions on electrical equipment that is disconnected, live, or near live equipment, please refer to (for example):

- IEC 11-27 - Work on electrical systems
- IEC EN 50110 parts 1 and 2 - Working of electrical systems.

PPE to be used:



RESIDUAL RISKS DUE TO SAFETY FUNCTIONS AND COMMAND/CONTROL SYSTEMS



In addition, some safety functions and the command/control systems **comply with Safety Category 1 of Standard: EN ISO 13849-1: application of safety principles and tested components.**

This requirement means that a failure may lead to losing the safety function.



Therefore there is a residual risk due to a failed stop/incorrect selection of movements according to that intended.



Before entering dangerous areas, opening guards, etc... every operator **must verify and ascertain that said mobile elements are still.**



In addition, before starting the machine functioning cycle, every operator **must verify and ascertain the absence of faults as, if they are not detected and verified, they may lead to losing the safety function.**

PPE to be used:



RESIDUAL RISK DUE TO HOT SURFACES



Residual risk **due to possible burns in correspondence of** every AC or brushless motor, transformer, etc... and following the opening of mobile guards due to the presence of parts **with a temperature above the burning level (45°C)** so as to perform adjustment, tooling operations, etc...



Personnel must operate with caution, respecting the indications on the affixed labels and in this manual and use the provided PPE. In addition, wait at least 60 minutes after power supply energy interruption before accessing elements for their replacement or for any other intervention.

Every operator, **as well as observing the instructions**, must also observe the admitted and forbidden uses included both in paragraph 2 and in signs attached to the machine and wear **protective clothing to avoid contact with hot elements and for short jobs where protective equipment cannot be used.**

PPE to be used:



Protective gloves



Safety footwear



Body protection



Eye protection







4.9. PLATES



The plates and signs must always be clearly visible and never be removed.
 The plates and signs are a safety instrument and must not be considered superficial.
 The user must immediately replace all worn and illegible safety and/or warning plates.

LIST AND MEANING OF PLATES ON THE MACHINE

All provision, danger, signal, etc. signs must be found near to the danger/access door and in the user instructions manual.

					
Eye protection	Protective gloves	Safety footwear	Body protection	Hearing protection	Hard hat

Affixed in proximity of the main pulpit or of the M.G. accessing the machine working area.



Affixed on the machine to indicate the direction of rotation of the table



ACCESS IS FORBIDDEN TO UNAUTHORISED PERSONS

Affixed in correspondence of the access areas to the machine



**IT IS FORBIDDEN TO USE NAKED FLAMES OR INCANDESCENT PARTS
 SMOKING IS FORBIDDEN**

Affixed in the areas of access to the machine



RESIDUAL RISK DUE TO CRUSHING OF THE HANDS.

Affixed in correspondence of the machine elements moving via maintained action controls and not segregated.



RISK OF SLIPPING AND FALLING

Affixed near slippery surfaces

STICKERS FOR ELECTRICAL EQUIPMENT



4.10. DESCRIPTION OF THE SAFETY FUNCTIONS



The safety devices and protections must not be removed if not for work purposes by the authorised service centre.

When they do need to be removed, it is important to immediately adopt suitable measures to highlight and minimise the consequential hazards.

The safety protection or device must be immediately put back into place once the reasons for their temporary removal have ceased.

Guards and safety devices on the machine

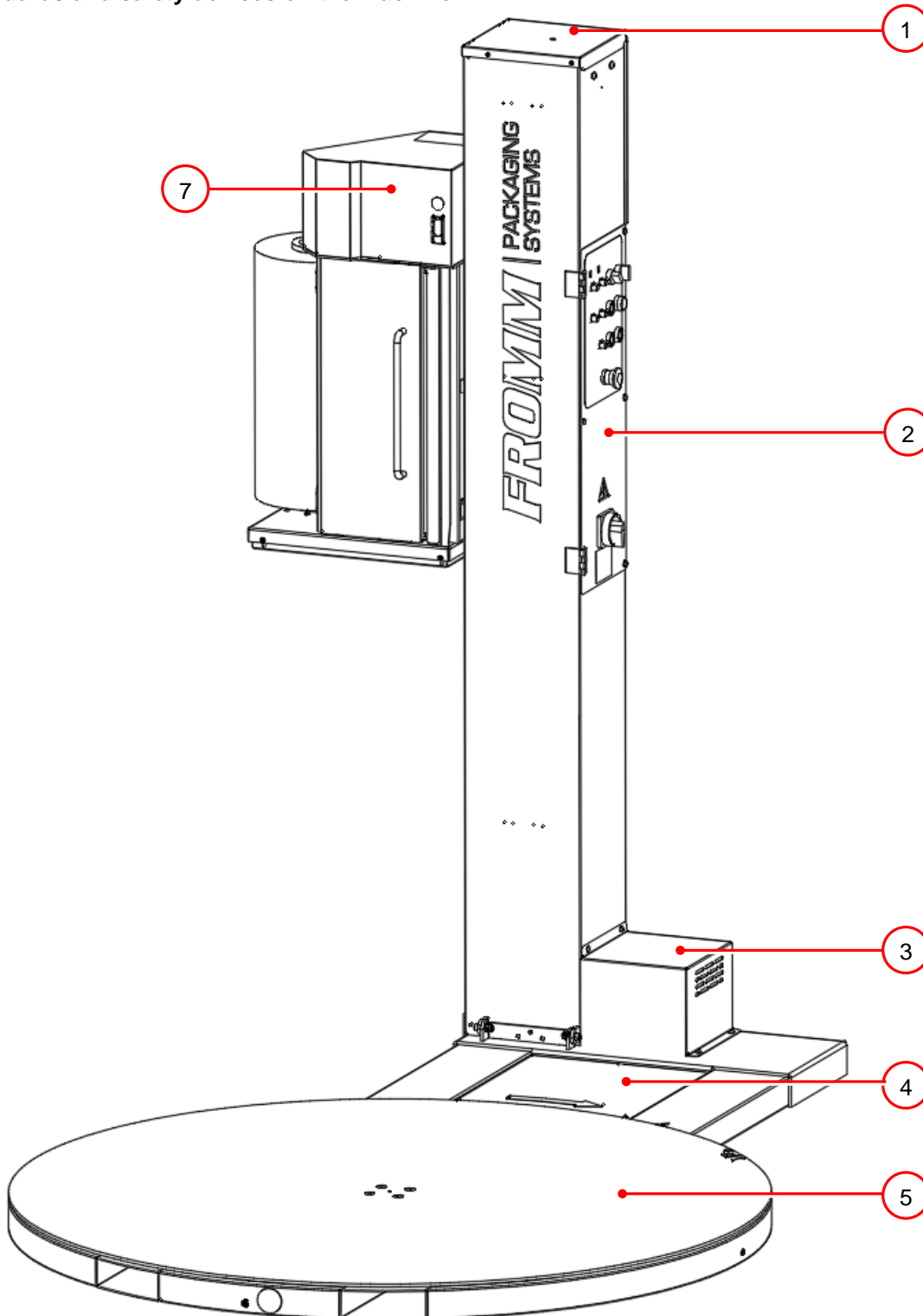

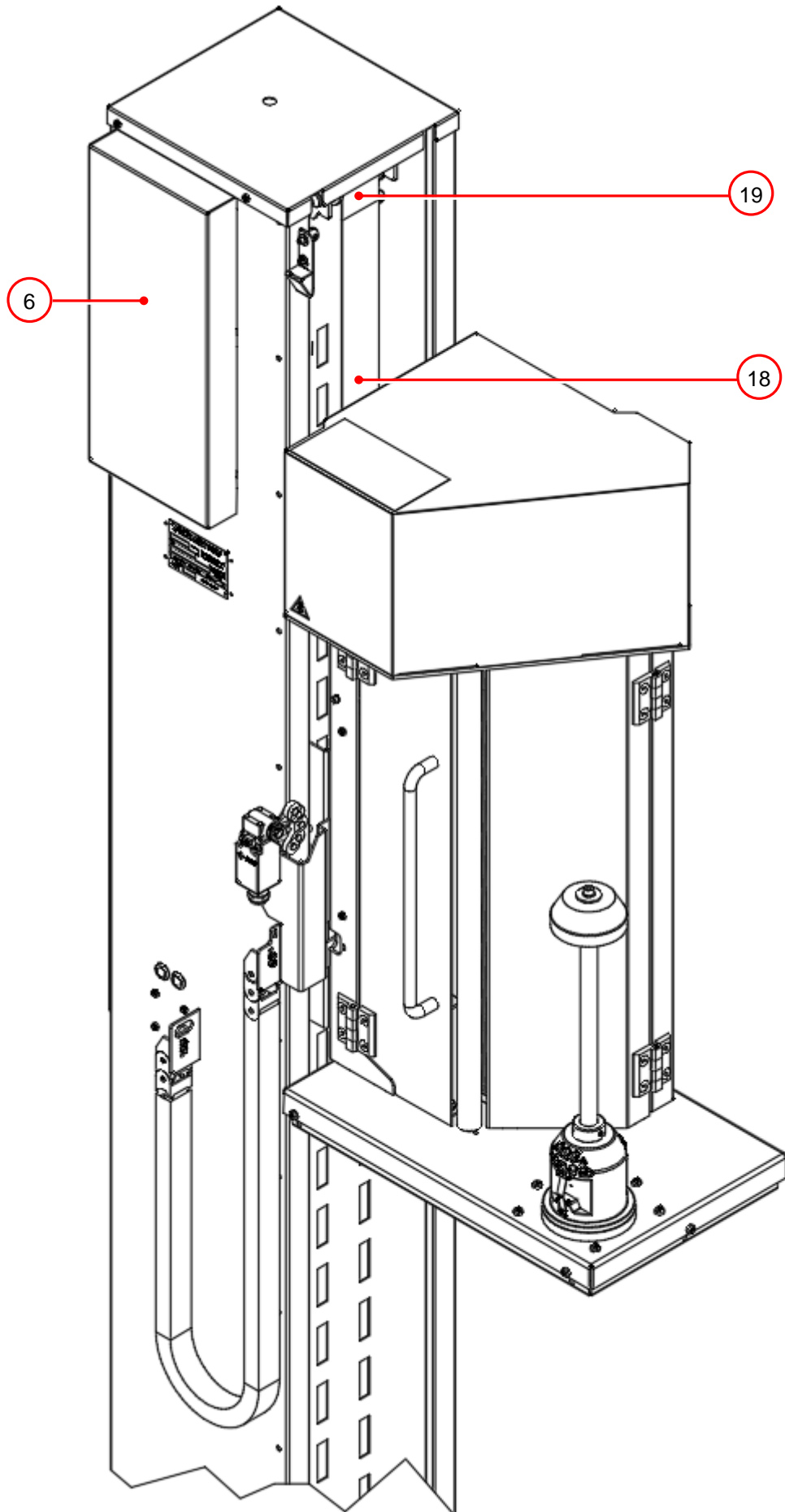

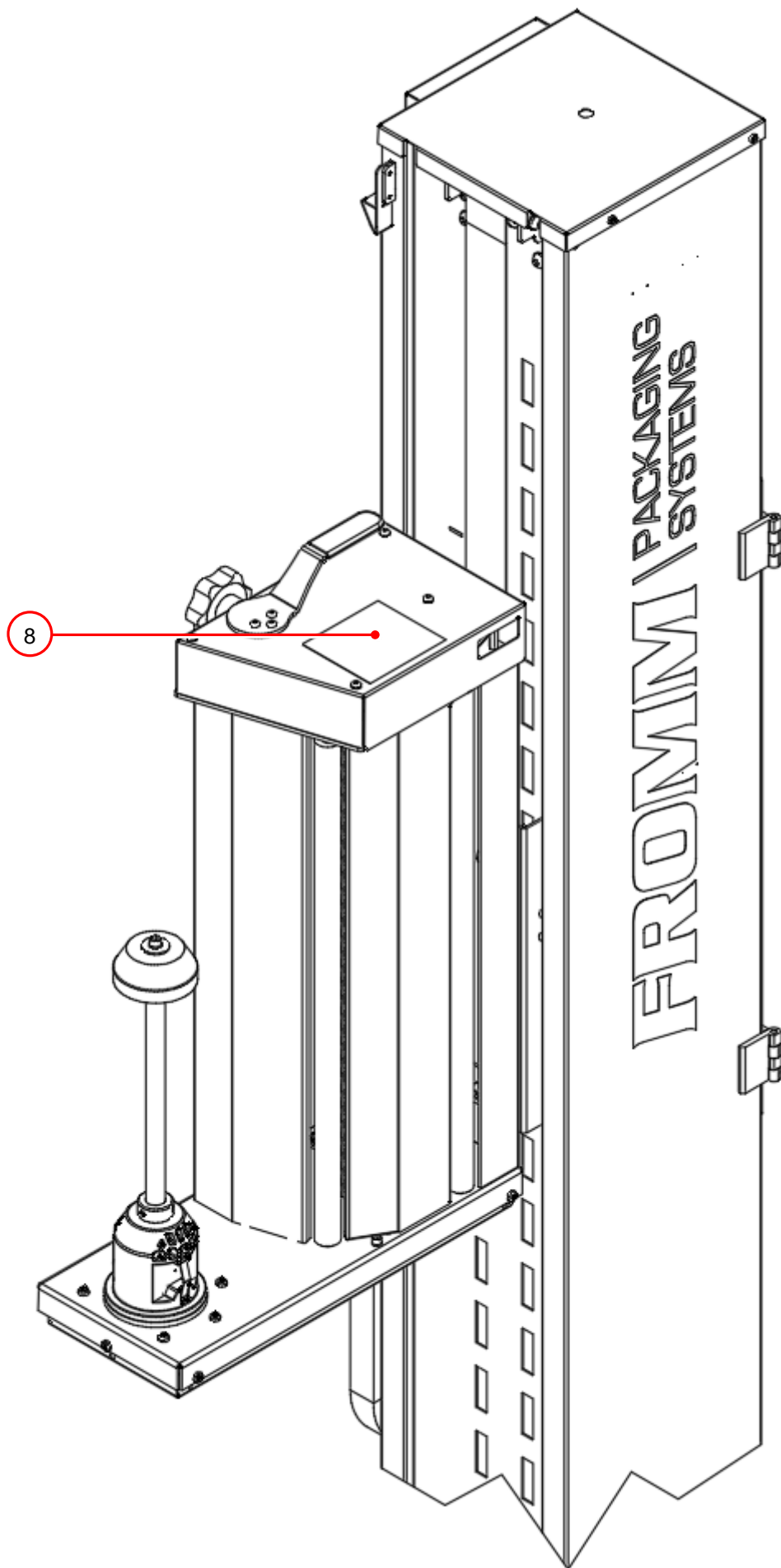

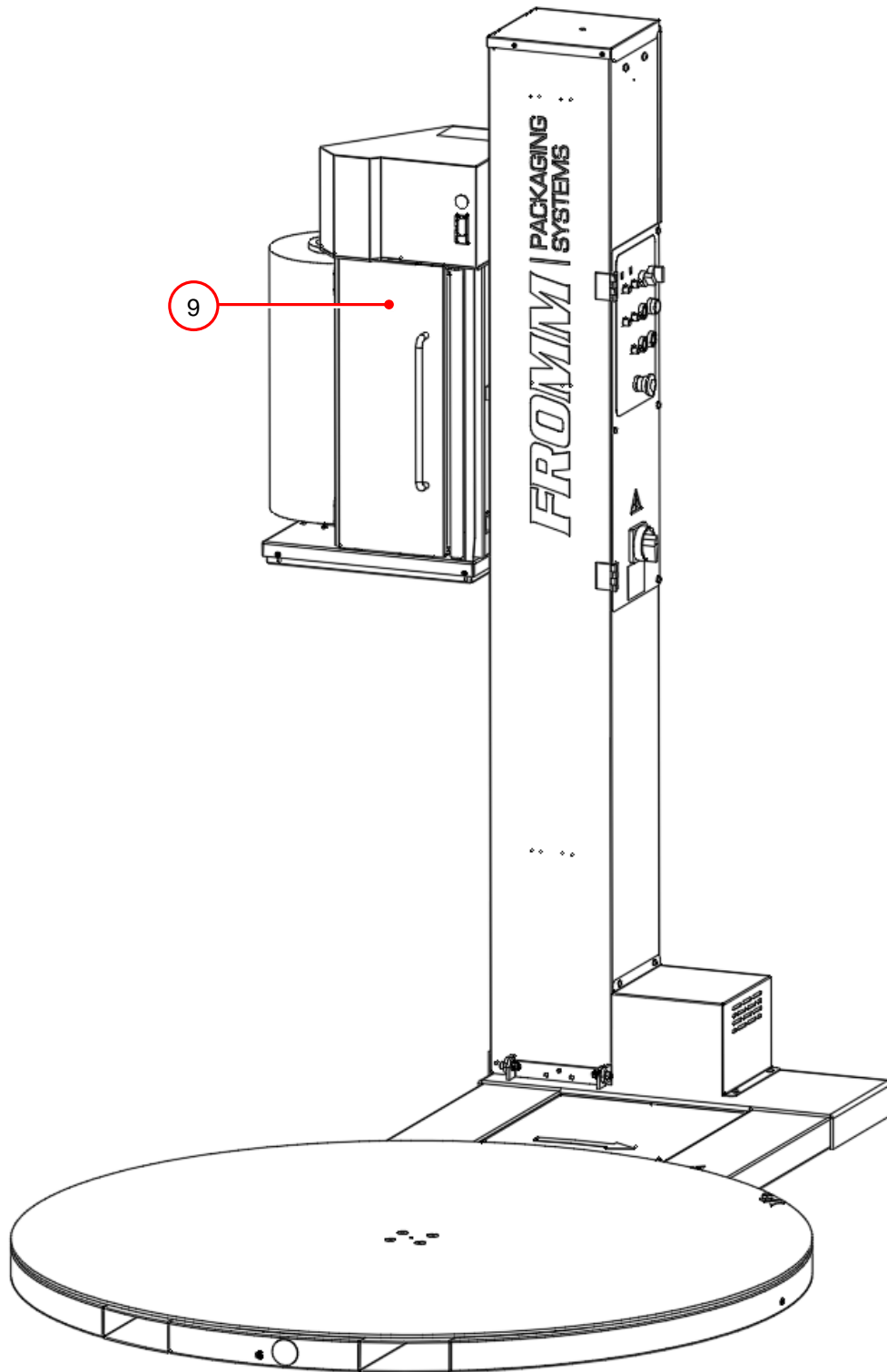

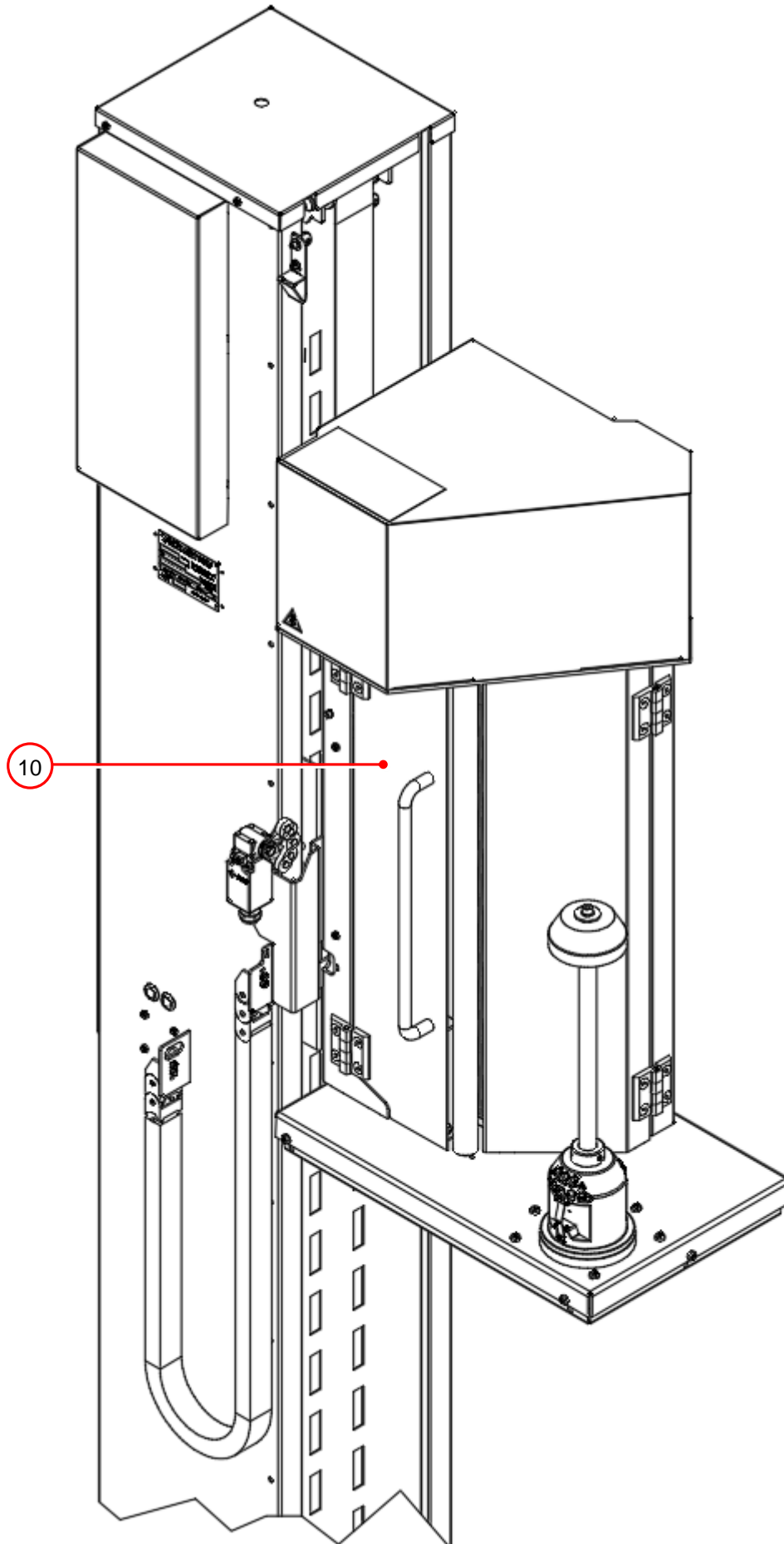

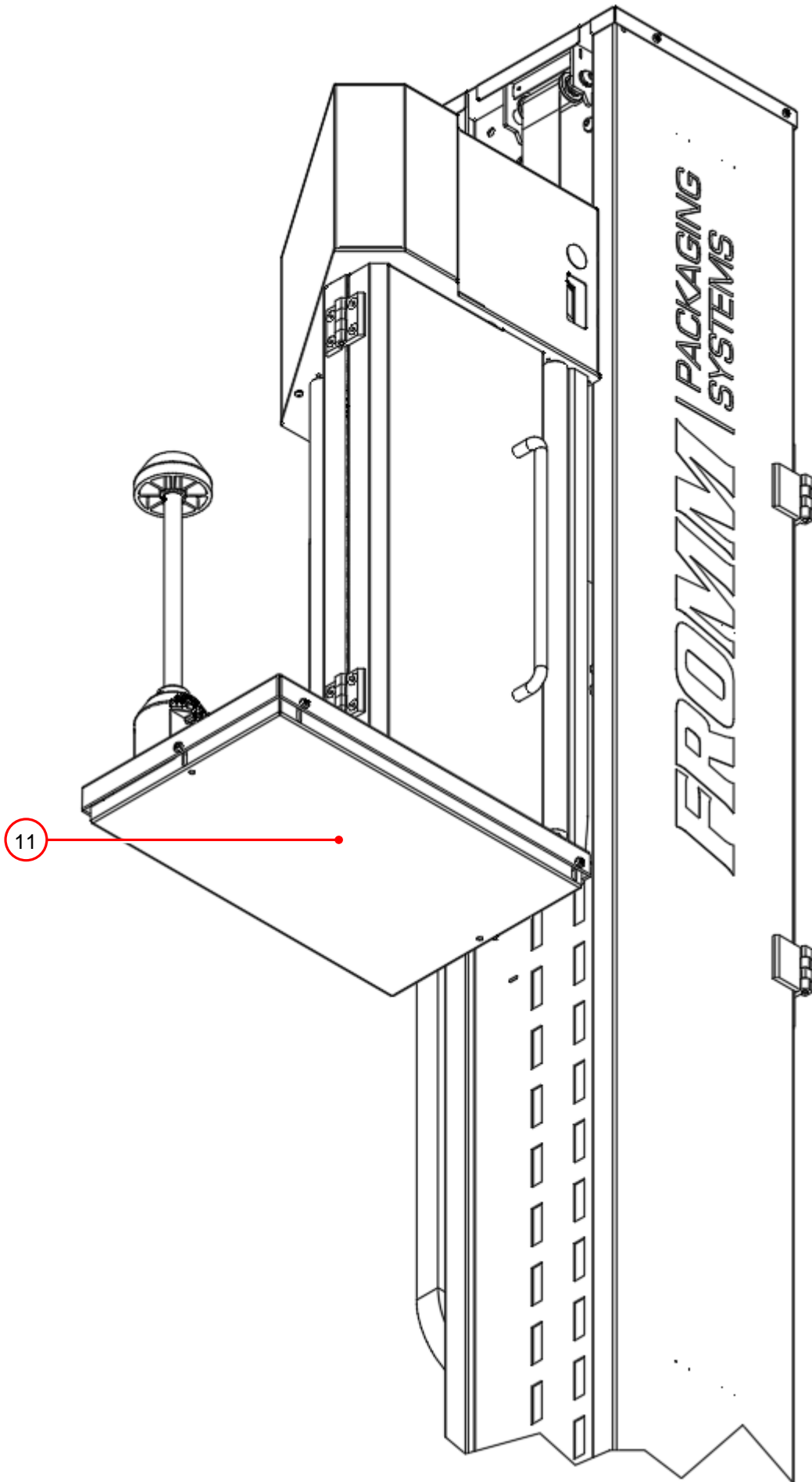

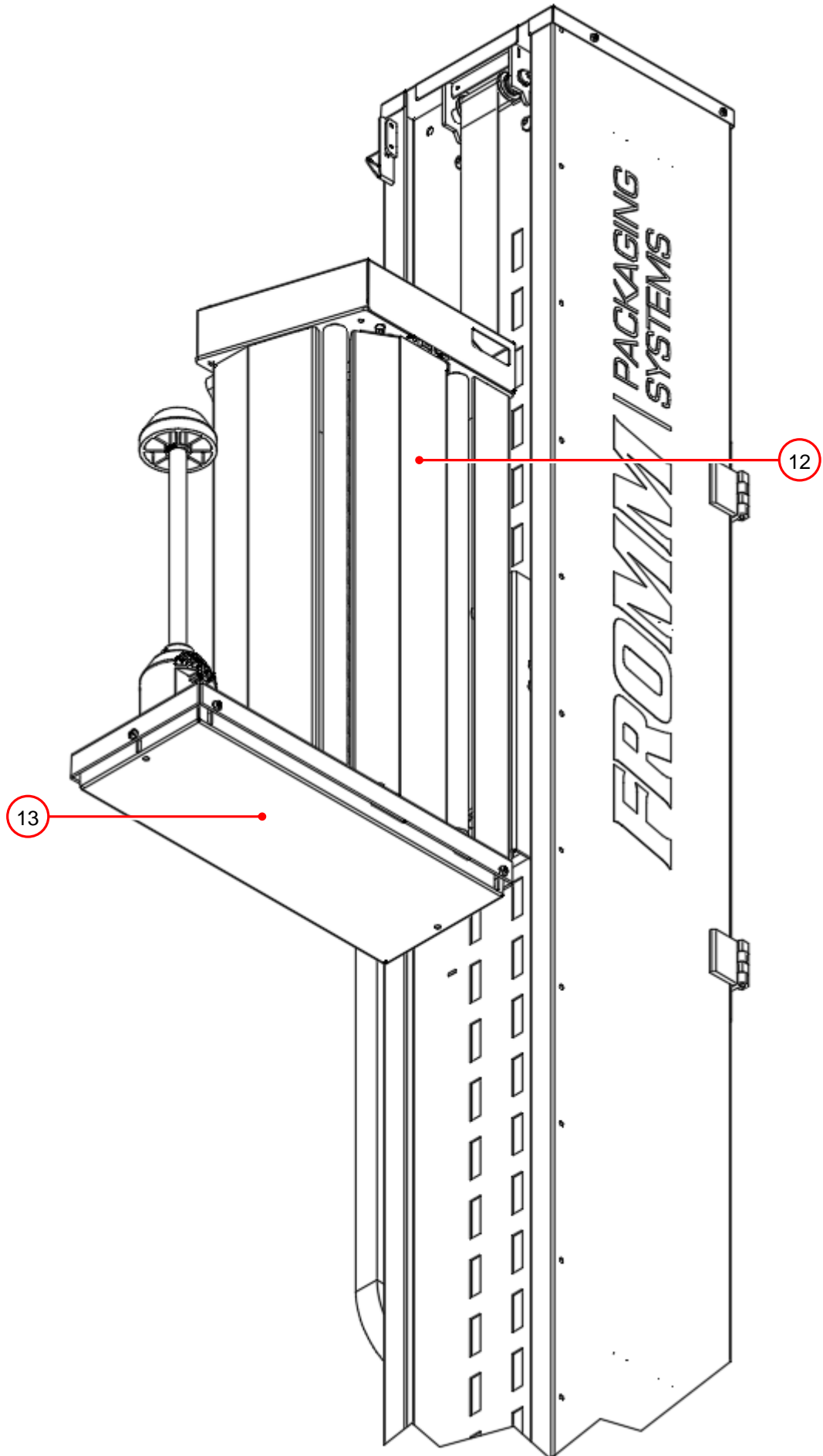

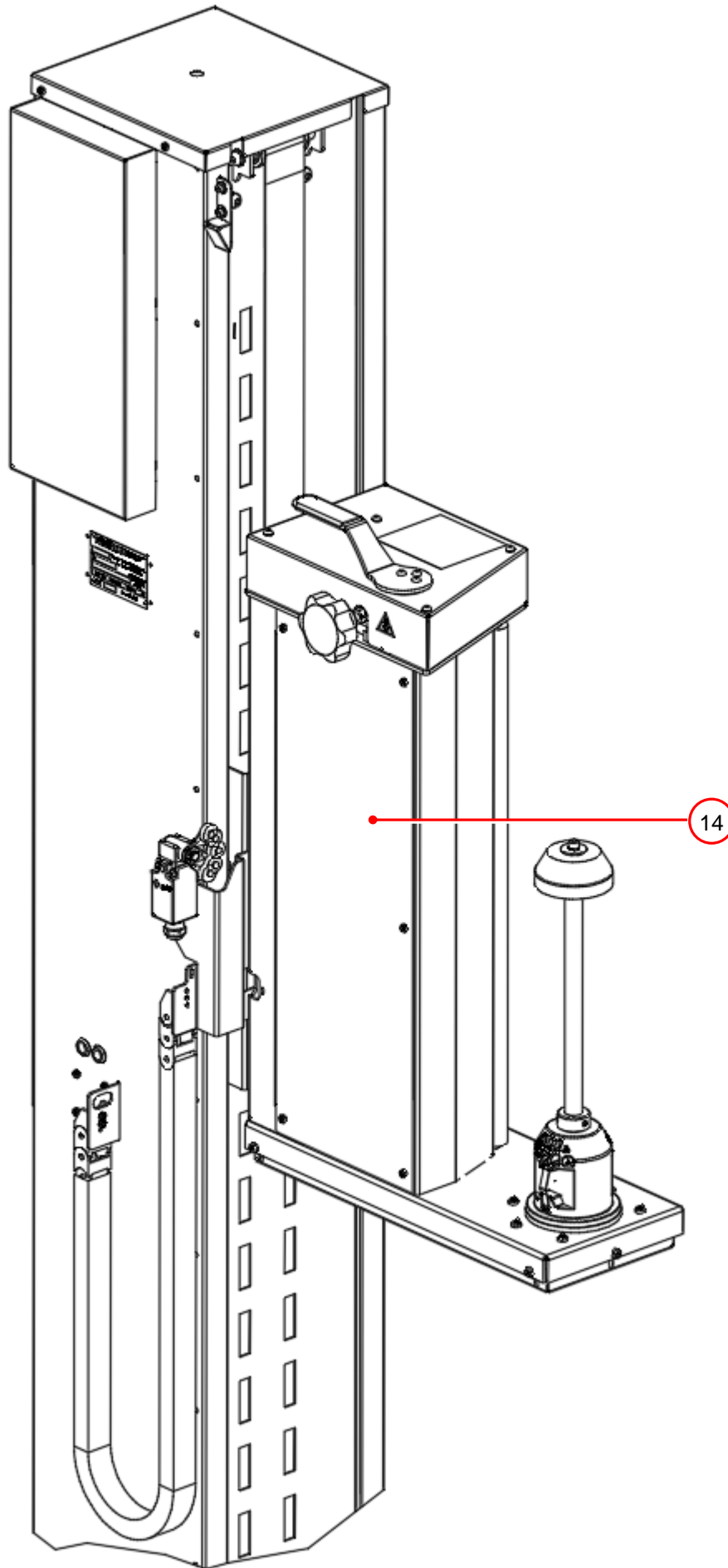

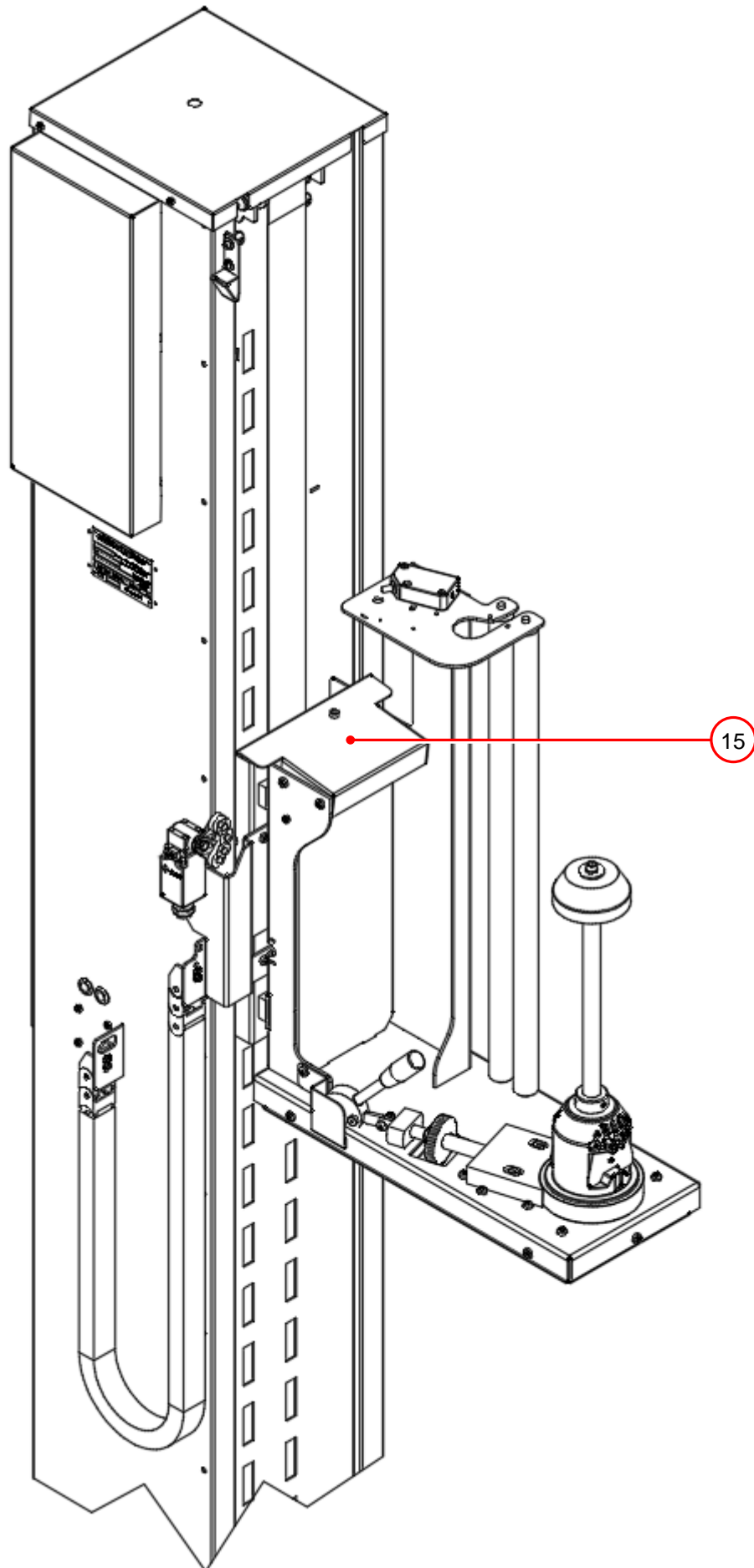

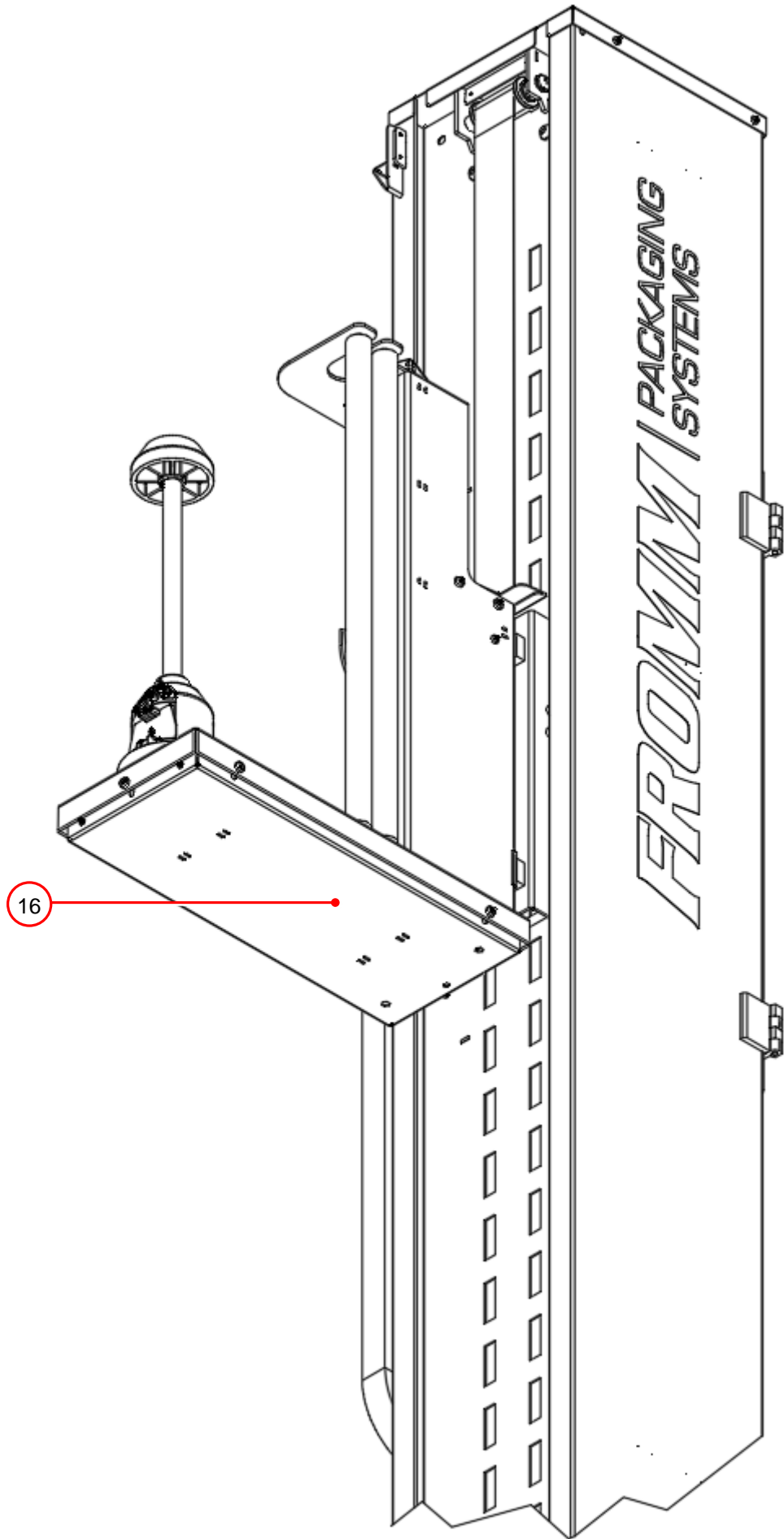

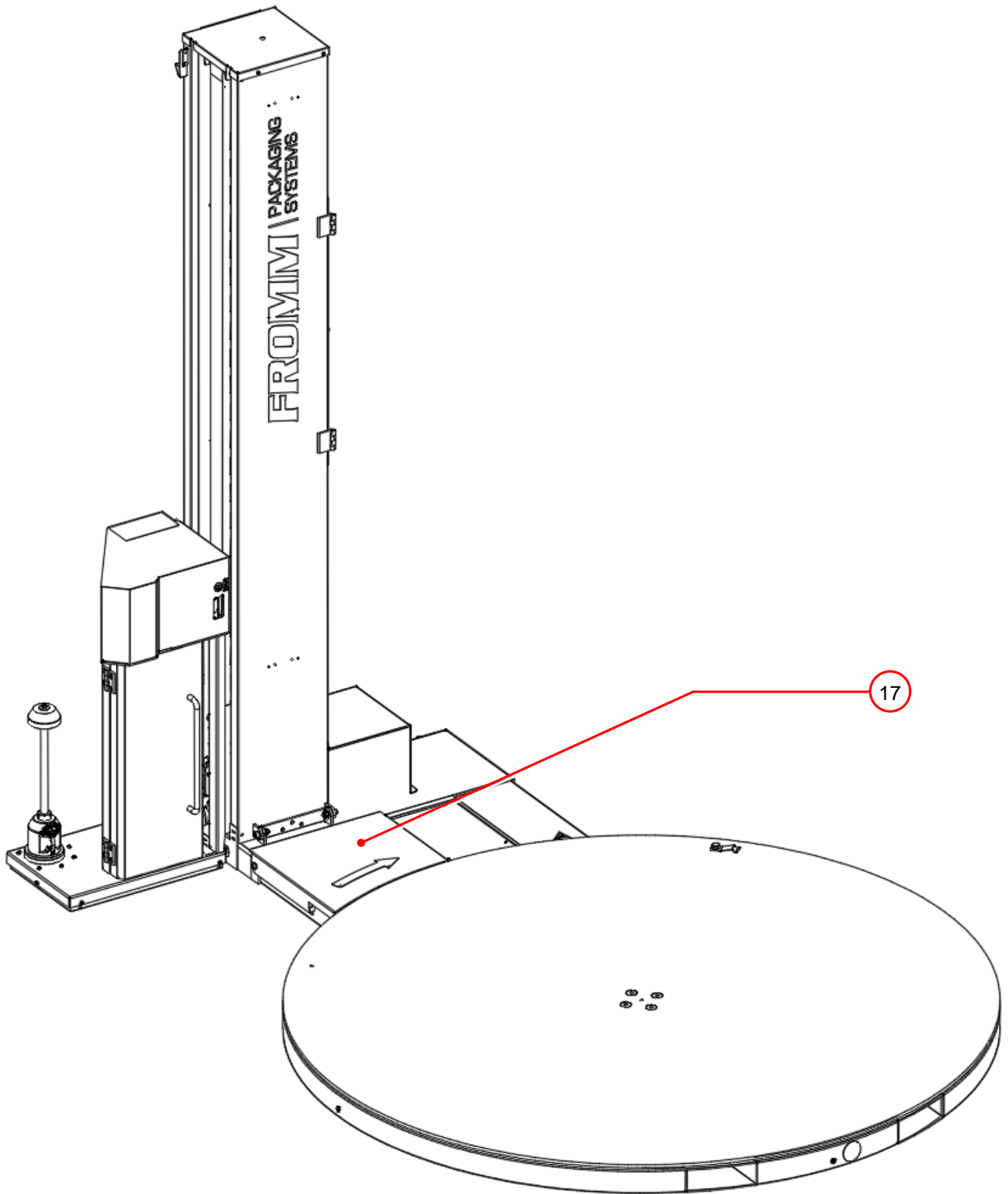

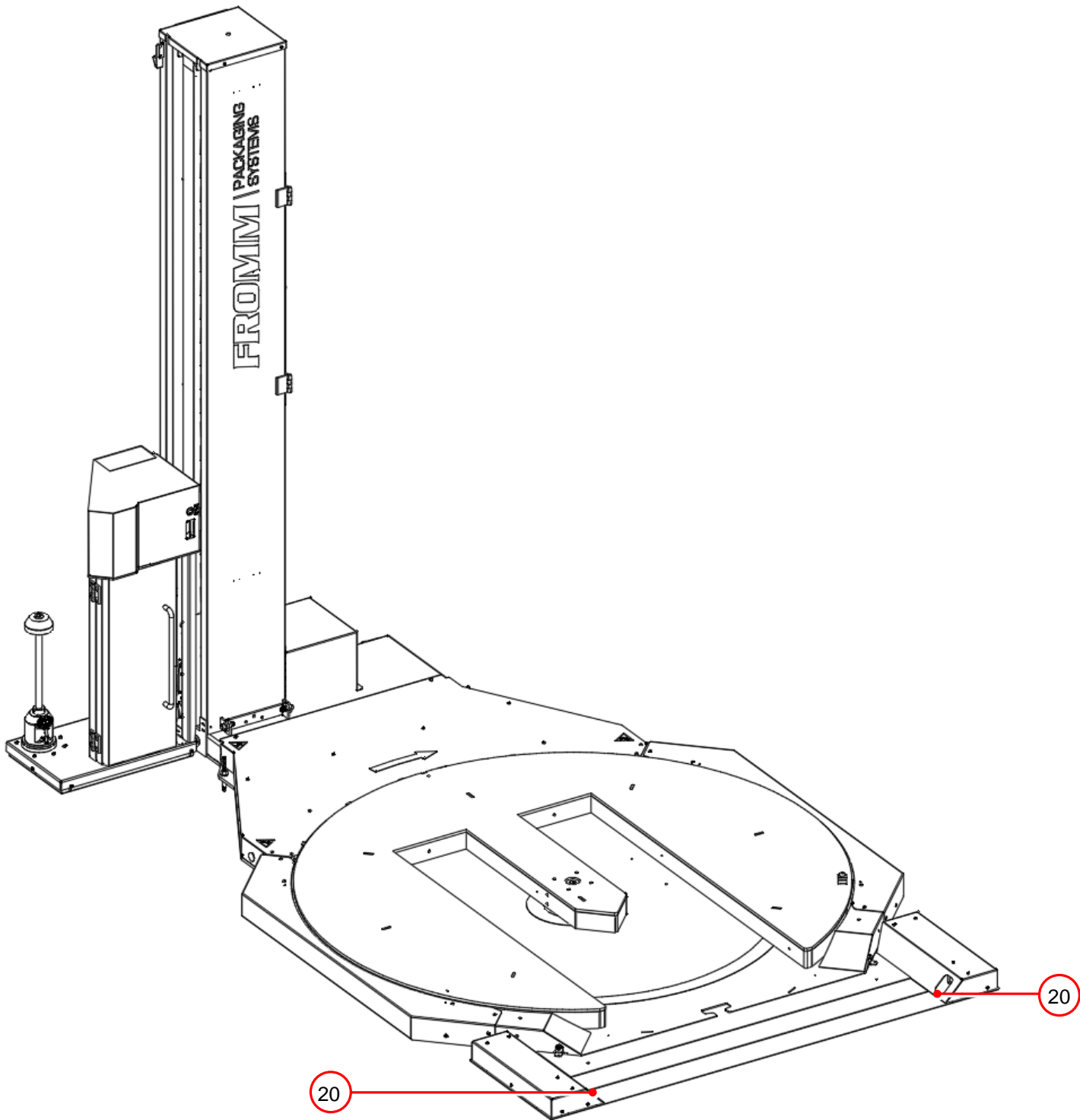

Ref.	PROTECTIVE DEVICES/GUARDS - POSITION	TYPE OF PROTECTED DANGER
1	Fixed guard	➤ Fixed guard: column upper casing, sheet metal, fixed to the machine column by screws, it segregates the dangerous internal mechanical devices.
2	Fixed guard	➤ Fixed guard: operator panel door, sheet metal, fixed to the machine column by screws, it segregates the internal electrical devices.
3	Fixed guard	➤ Fixed guard: table reducer casing, sheet metal, fixed to the table structure by screws. It segregates the dangerous internal mechanical devices.
4	Fixed guard	➤ Fixed guard: table chain casing, sheet metal, fixed to the table structure by screws. It segregates the dangerous internal mechanical devices.
5	Fixed guard	➤ Fixed guard: rotary table disc, sheet metal, fixed to the table ring with screws. It segregates the dangerous internal mechanical devices.
6	Fixed guard	➤ Fixed guard: carriage gearmotor casing, sheet metal, fixed to the column with screws. It segregates the dangerous internal mechanical devices.
7	Fixed guard	➤ Fixed guard: carriage C3 upper casing, sheet metal, fixed to the machine column by screws, it segregates the dangerous internal mechanical devices.
8	Fixed guard	➤ Fixed guard: carriage C2/C4 upper casing, sheet metal, fixed to the machine structure by screws, it segregates the dangerous internal mechanical devices.
9	Mobile guard	➤ Mobile guard: carriage C3 front door, sheet metal, fixed to a side of the carriage structure by hinges and kept closed by magnets on the other side, it segregates the dangerous internal mechanical devices. Performance level according to EN ISO 13849-1: Safety PL “C” category 1.
10	Mobile guard	➤ Mobile guard: carriage C3 rear door, sheet metal, fixed to a side of the carriage structure by hinges and kept closed by magnets on the other side, it segregates the dangerous internal mechanical devices. Performance level according to EN ISO 13849-1: Safety PL “C” category 1.
11	Fixed guard	➤ Fixed guard: carriage C3 toe board, sheet metal, free to move on guides to detect the presence of obstacles.
12	Mobile guard	➤ Mobile guard: carriage C2/C4 front door, sheet metal, fixed to a side of the carriage structure by a pin and kept closed by magnets on the other side, it segregates the dangerous internal mechanical devices. Performance level according to EN ISO 13849-1: Safety PL “C” category 1.
13	Fixed guard	➤ Fixed guard: carriage C2/C4 toe board, sheet metal, free to move on guides to detect the presence of obstacles.
14	Fixed guard	➤ Fixed guard: carriage C2/C4 rear panel, sheet metal, fixed to the machine structure by screws, it segregates the dangerous internal mechanical devices.
15	Fixed guard	➤ Fixed guard: carriage C1 hand protector, sheet metal, fixed to a side of the carriage by a pin and kept lifted on the opposite side by a spring.
16	Fixed guard	➤ Fixed guard: carriage C1 toe board, sheet metal, free to move on guides to detect the presence of obstacles.
17	Fixed guard	➤ Fixed guard: table oscillating mat, diameter 1650 mm, sheet metal, fixed to a side of the table structure by a pin and kept lifted by a spring on the opposite side, it prevents the operator from placing him/herself between the column and the table.
18	Fall arrest device	➤ Fall arrest device: it prevents the carriage from falling should the lifting belt break.
19	Belt tension detector	➤ Belt tension detector: It detects the lack of tensioning of the carriage lifting belt, halting the machine.
20	Light curtain	➤ Light curtain: it prevents the machine from functioning should the access opening of the open table be used: more precisely, while the table is rotating, the table and any other movement are halted whenever a foreign body is detected between the photocell and the reflector. Performance level according to EN ISO 13849-1: Safety PL “C” category 1.

In relation to the **fixed guards**, it should also be noted that:

1. the fixed guards' dimensions do not leave openings in the protected dangerous work area when fixed in place
2. the fixed guards not permanently sealed to the machine, are fixed with screws requiring use of special wrenches (Allen) and only the maintenance technicians can remove them using suitable wrench
3. only the maintenance technician may access areas protected by a fixed guard. The operator must never, in any case, attempt opening a fixed guard
4. a guard cannot be assembled in the wrong position, leaving dangerous openings in the housing
5. if the guards are not fixed in their seat using special screws, they cannot remain closed and rested in that seat without fixing elements.

Access by 14-year-olds, or older, was considered when dimensioning and choosing the safety devices and guards.



Both the operator and the maintenance technician **have access to compartments protected by movable guard**. The operator must never, in any case, attempt intentionally by-passing a movable guard.



Only the maintenance technician may **access areas protected by a fixed guard**. The operator must never, in any case, attempt intentionally by-passing a movable guard.



All guards and safety devices must be correctly installed, adjusted/registered and be operational by scrupulously and carefully following the use, installation and maintenance manual of the same safety devices (all delivered with the equipment) and this manual, **before commissioning**.



The manufacturer absolutely **forbids any tampering**, even partial or temporary, with any of the safety devices as they have been installed to guarantee the physical safety of operators and any other personnel present.

Violating this rule causes risks and is in contrast with the current health and safety at work laws.

CHAP.5 TRANSPORT, INSTALLATION AND HANDLING

5.1. STORAGE, TRANSPORT AND HANDLING

5.1.1. STORAGE

The machine intended for indoor installation in the event of storage, must be deposited in warehouse, in ventilated premises, protected from dust. The delivered elements must remain packaged until final installation.

In the event of a **long period of inactivity**, the machine must be stored taking precautions suited to the duration and location of storage:

1. Store the machine in a closed environment.
2. Protect the machine against stress and collisions.
3. Protect the machine against dampness and excessive temperature ranges (refer to the following table).
4. Prevent the machine from coming into contact with corrosive substances.
5. Check the packaging has not been damaged and is perfectly dry.
6. If the machine is housed inside a container, the storage area must be covered and protected against direct atmospheric agents like rain, snow and hail, and must only be accessible to authorised personnel.

The machine has been designed to support transport and storage temperatures, dampness and vibrations.

Ambient temperature	+5° / +40 °	Avoid places where sudden temperature changes occur, that might generate condensation or freezing
Storage temperature	-5° / +50 °	
Relative humidity	must not exceed 50% at the temperature of +40°C or 90% at the temperature of +20°C	
Vibrations	5.9 m/s ² (0.6G) or higher	
Atmospheric pressure	900 mbar or greater	

These storage temperatures are intended **as short-term values**, e.g. during transportation. Condensation or freezing normally happen where sudden temperature changes are high. Such places must be avoided even if, in these cases, relative humidity falls within the table values.

5.1.2. SIZE, WEIGHT AND HANDLING OF THE INDIVIDUAL PARTS

OVERALL MEASUREMENTS

H Max Film	2100	2500	3000
E	2060	2460	2950
F (carriage C1)	2270	2670	3160
F (carriage C2)	2350	2750	3240
F (carriage C3)	2460	2860	3350
F (carriage C4)	2330	2730	3220

DISC	Ø1500	Ø1650	Ø1800	Ø2200
A	2265	2265	2635	3035
B	2280	2280	2650	3050
C	73	75	75	75
D	1565	1645	1790	2190

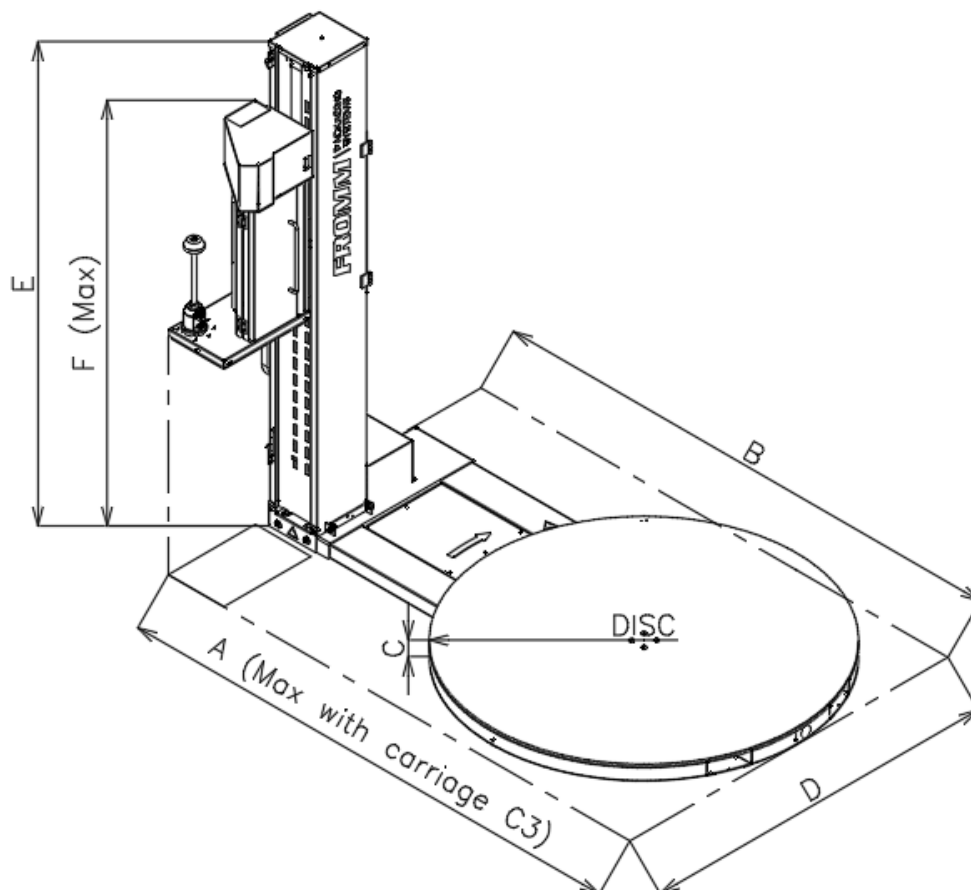

OVERALL MEASUREMENTS

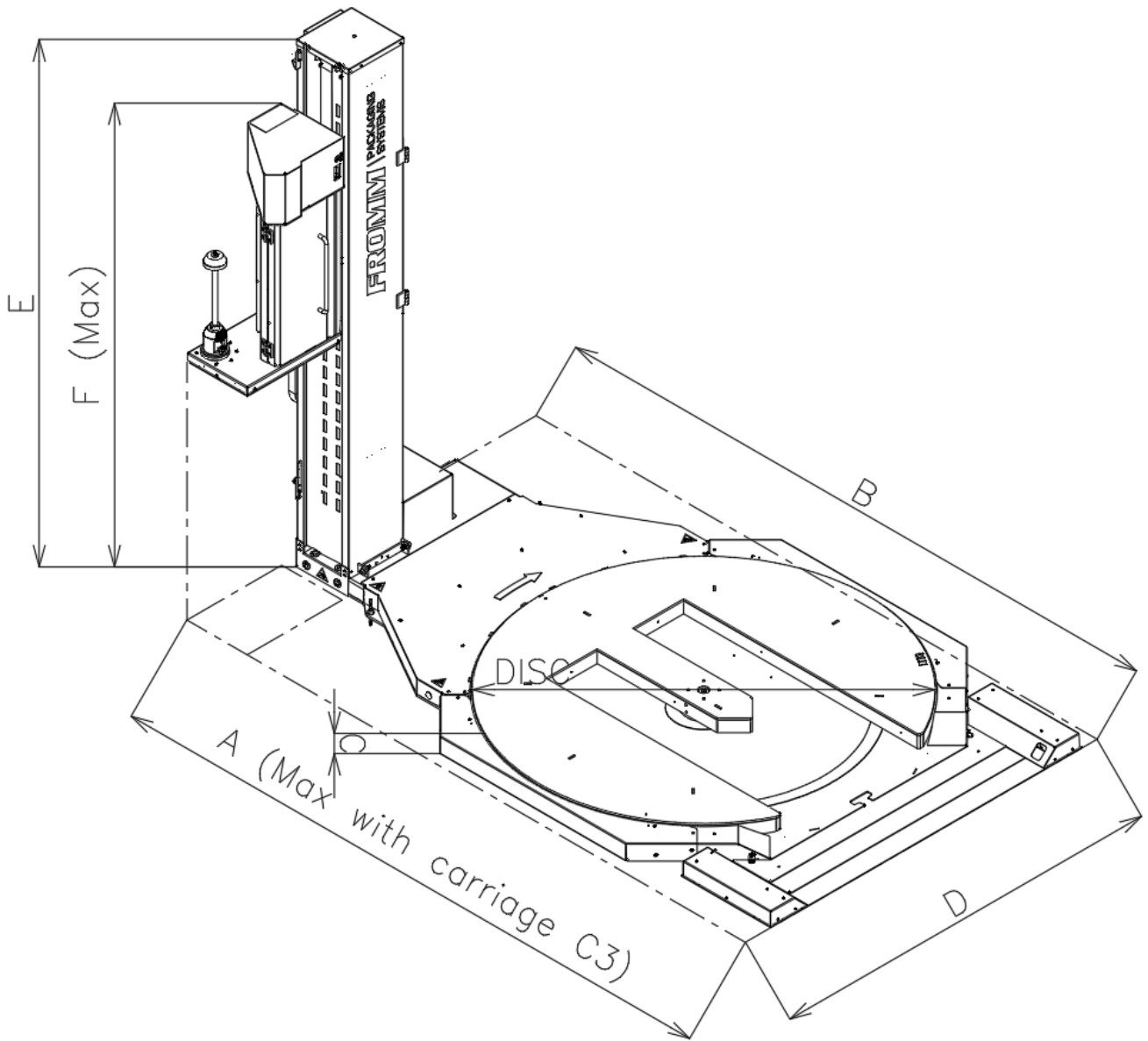

FRONT SIDE OPENING

Machine with Table Open with Front Access

OVERALL MEASUREMENTS

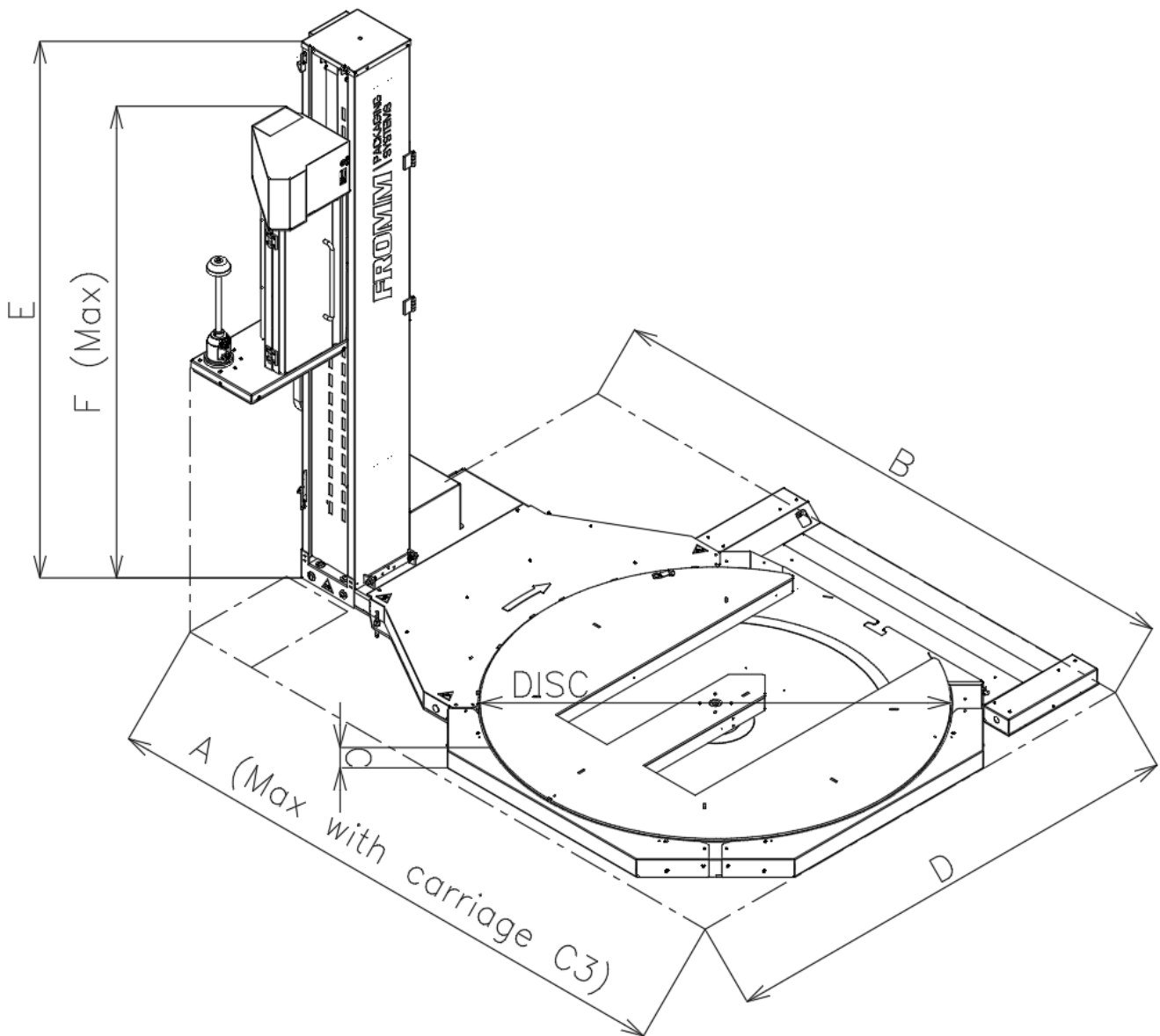

RIGHT SIDE OPENING

Machine with Table Open and Right Side Access.

OVERALL MEASUREMENTS

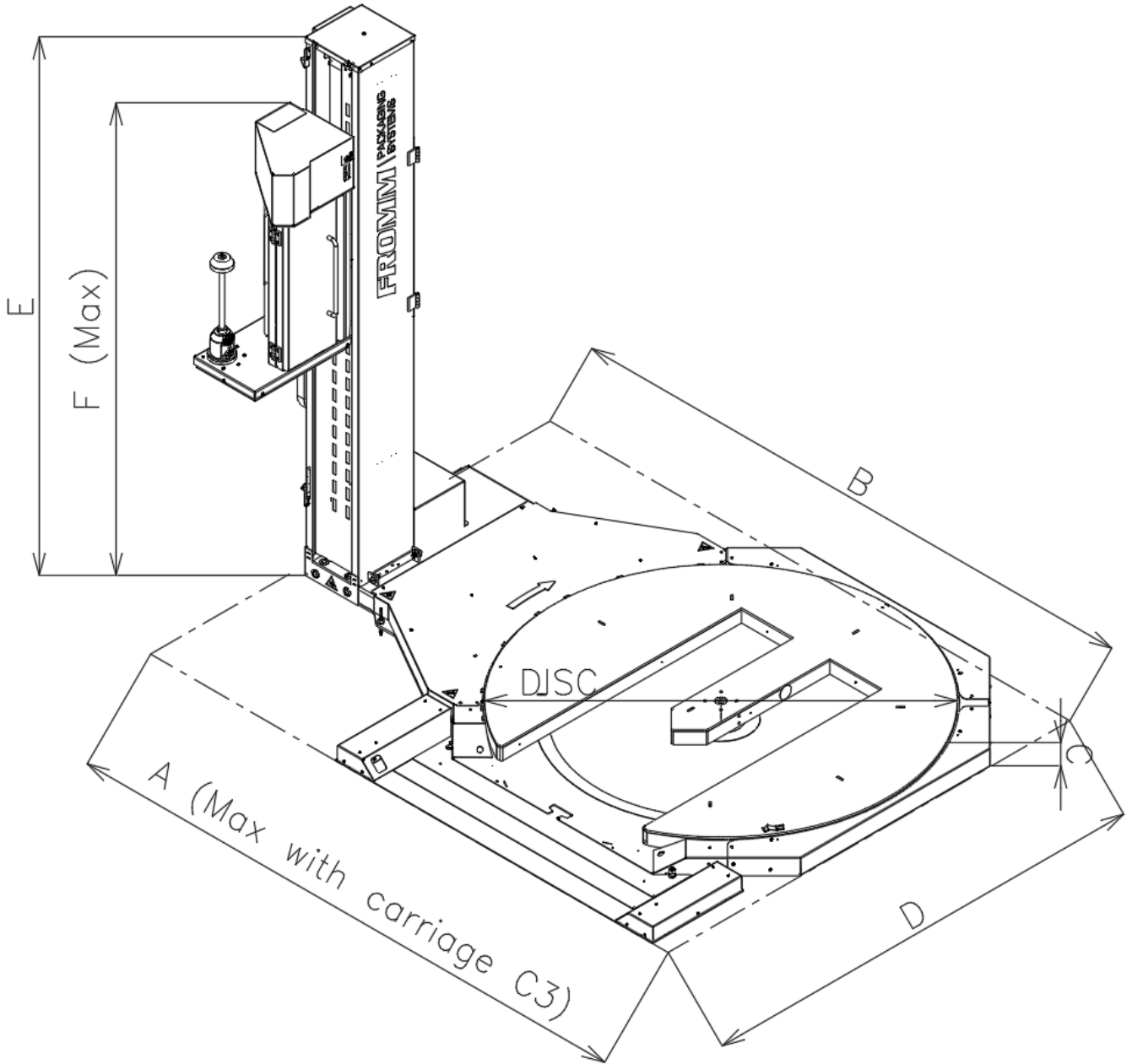

LEFT SIDE OPENING

Machine with Table Open and Left Side Access.

OVERALL MEASUREMENTS

DISK	Ø1500			Ø1650		
	FRONT	RIGHT	LEFT	FRONT	RIGHT	LEFT
A	2520	2285	2285	2760	2525	2525
B	2530	2295	2295	2770	2535	2535
C	77			77		
D	1585	1820	1775	1740	1970	1970

Values referred to the machine with Table Open.

5.1.3. REMOVING THE PACKAGE - OPENING INSTRUCTIONS

PACKAGE DESCRIPTION.

The machine is generally shipped wrapped in a polypropylene casing, fixed by a strap in a wooden structure.

HOW TO OPEN AND INSTALL

Contact the FROMM Service Centre.

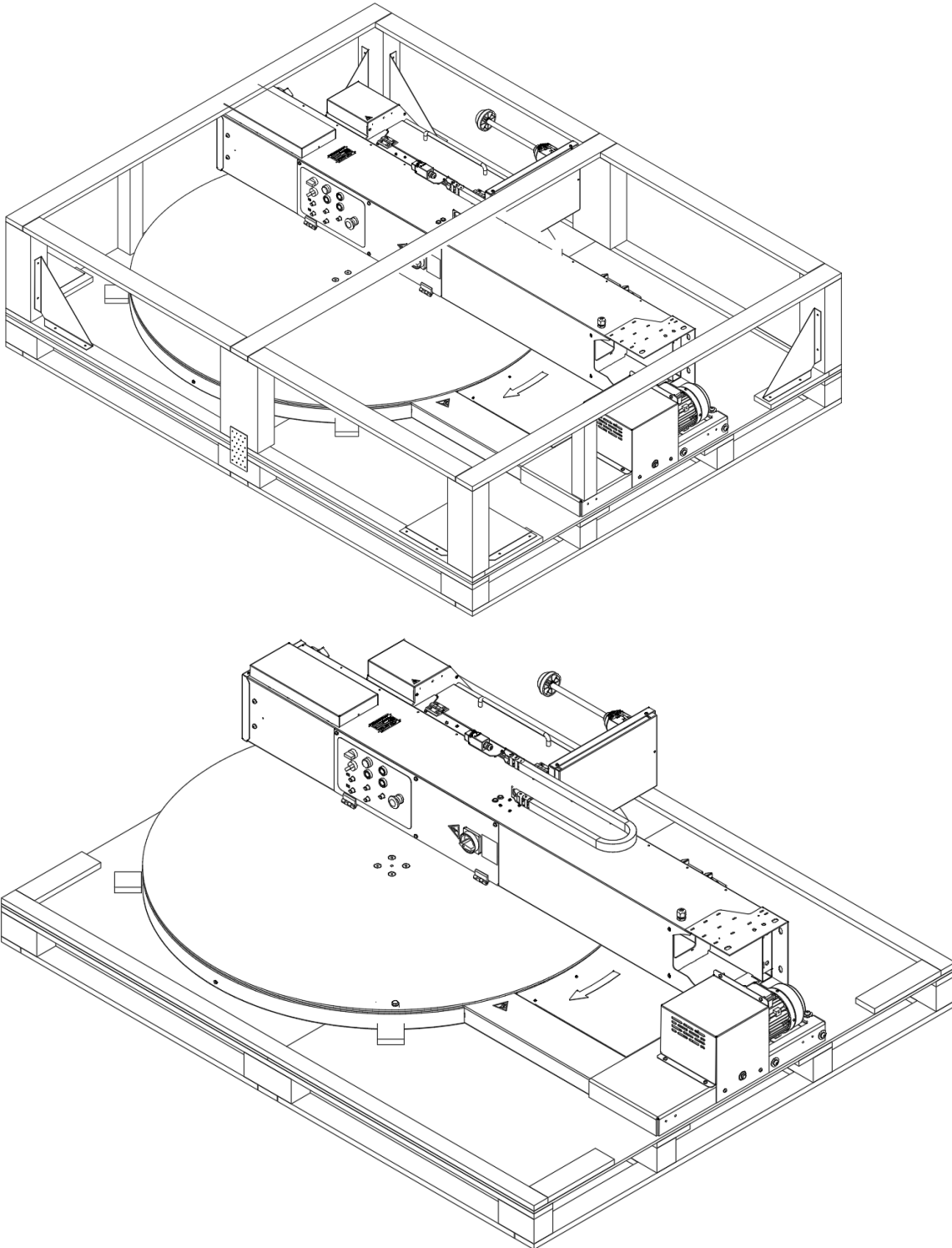

HOW TO DISPOSE OF THE PACKAGING MATERIAL



The polyethylene or cardboard packaging can be disposed of separating the main parts according to the chemical/physical nature of the materials, and loading them onto the transport vehicle for scrapping (respecting the general principles of differentiated waste collection).



Dispose of the materials in compliance with the applicable regulations, seeking advice from the delegated authorities and/or the assistance of specialist companies authorised for waste sorting/waste disposal. Make sure that plastic, metals and electric components are properly separated **for subsequent obligatory waste sorting**.

The employer **must be aware of the statutory legislation in force in the country of use, and must comply with such provisions**.

The act of abandoning the machine and electrical equipment in the environment **is forbidden, and may be subject to penalties**.



Attention danger of pollution: do not disperse the packaging in the environment but keep it for future transportation or send it to recycling companies.

The buyer is responsible for assessing and managing the biological compatibility of the products used for packaging.

5.2. PRELIMINARY PREPARATION AND ADJUSTMENT OPERATIONS



Furthermore, the safety measures and indications against residual risks must be respected during activities (see chapter 4).

5.2.1. FILM LOADING

The machine must be placed on a suitably-resistant stable level surface.

Film

LLDPE polyethylene material	Max 35 µm / 0.00138"
Reel core inner diameter	76mm / 3"
Reel outer diameter	Max 250 mm / 9.84"
Filler width	Max 500 mm / 19.68"

IMPORTANT: CLEANING RUBBER ROLLERS

It is important to clean the rubber rollers of the stretching unit with a damp cloth every month so as to guarantee a correct adhesion between the rubber roller and the film.

Carriage C1 (carriage with brake on reel)

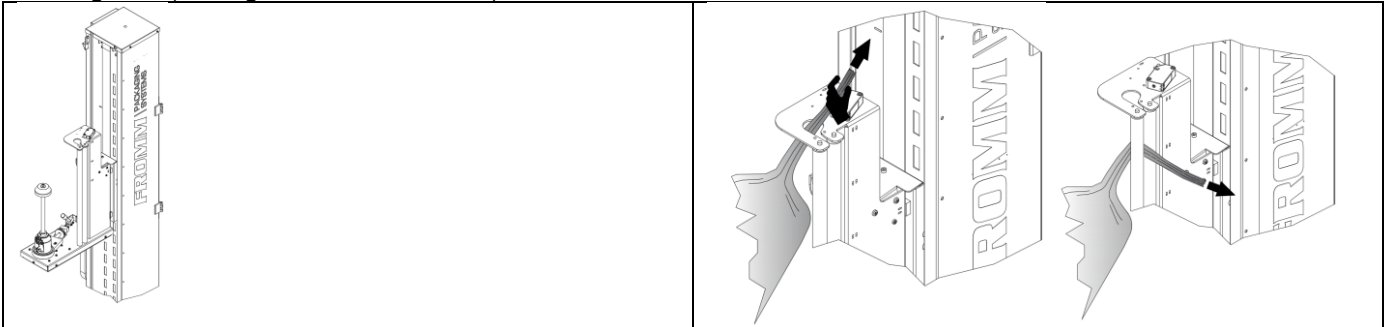

Carriage C2 (carriage with brake on rubber roller)

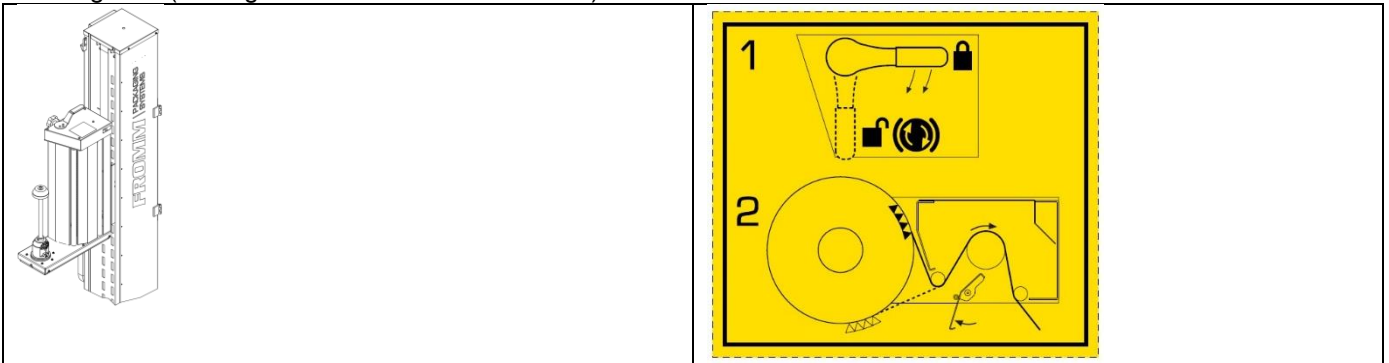

Carriage C3 (carriage with one motor, fixed pre-stretch)

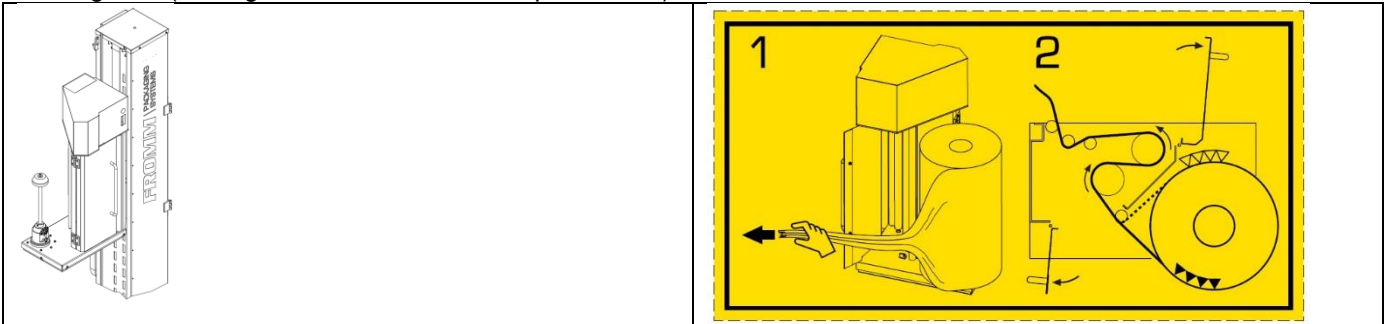

Carriage C4 (carriage with electromagnetic clutch)

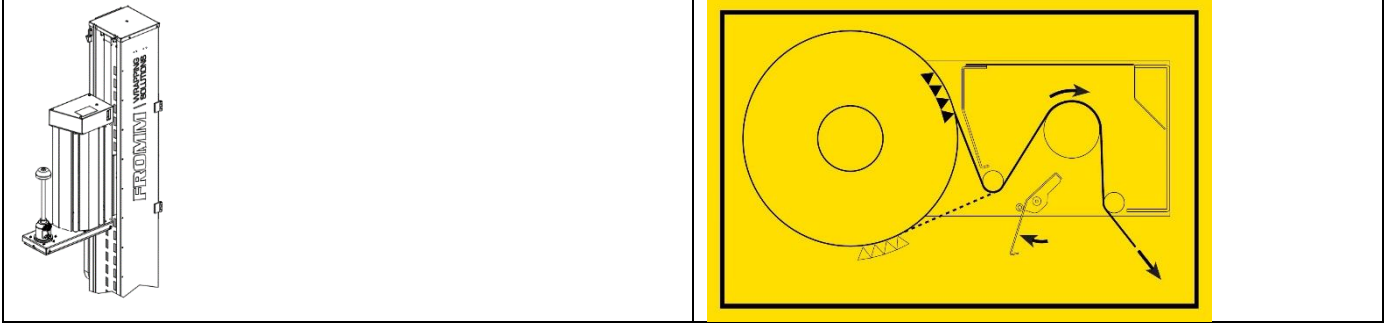

5.2.2. CARRIAGE BRAKING SYSTEM

Carriage C1 (carriage with brake on reel)

- Position 1 - Deactivated brake, roller holder free
- Position 2 - Activated brake, roller holder blocked
- Rotate the wheel (3) to increase/decrease the insertion of the clutch and therefore the tensioning of the film between the carriage and pallet.

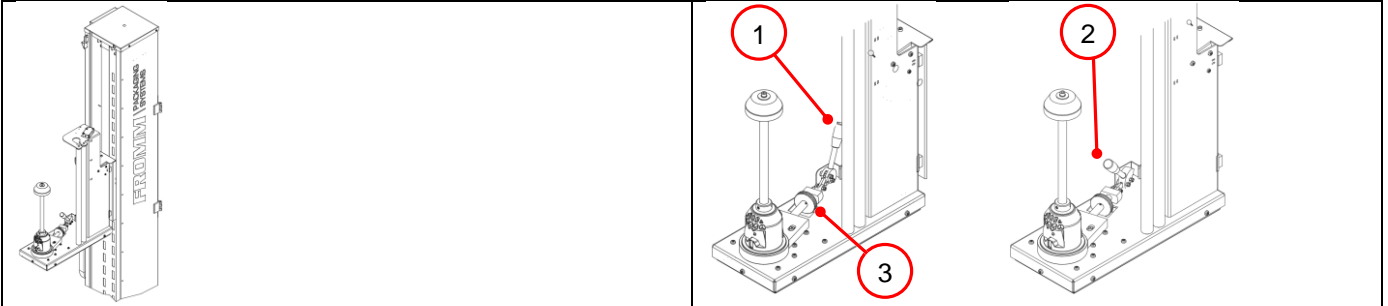

Carriage C2 (carriage with brake on rubber roller)

- Position 1 - Deactivated brake, roller holder free
- Position 2 - Activated brake, roller holder blocked
- Rotate the wheel (3) to increase/decrease the insertion of the clutch and therefore the tensioning of the film between the carriage and pallet.

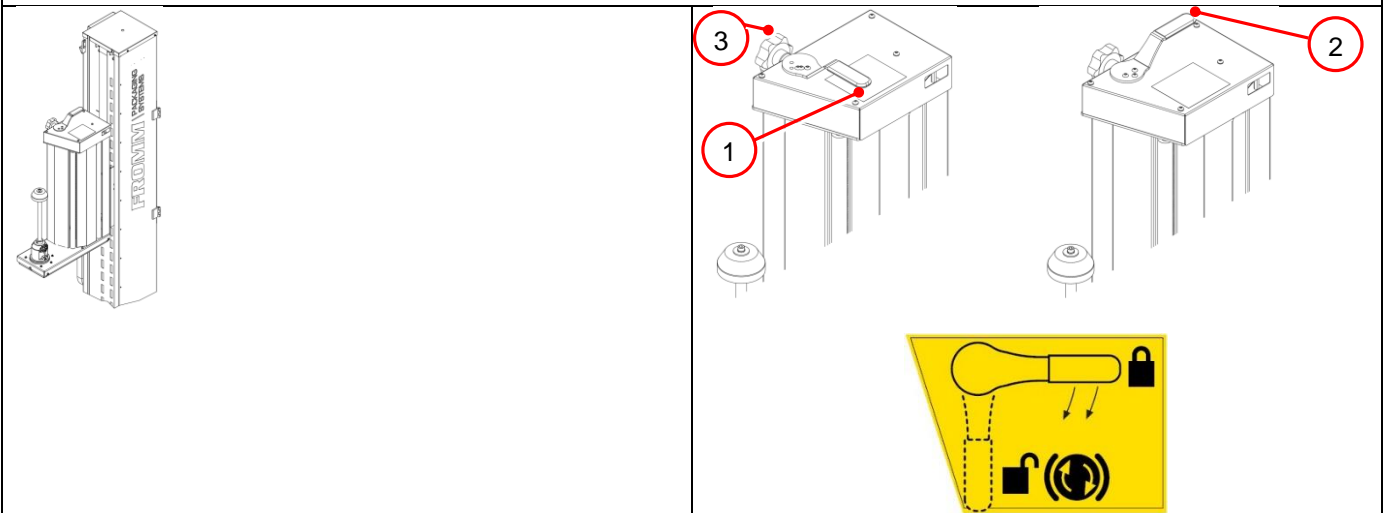

Carriage C3/C4 (carriage with one motor fixed pre-stretch and carriage with electromagnetic clutch)



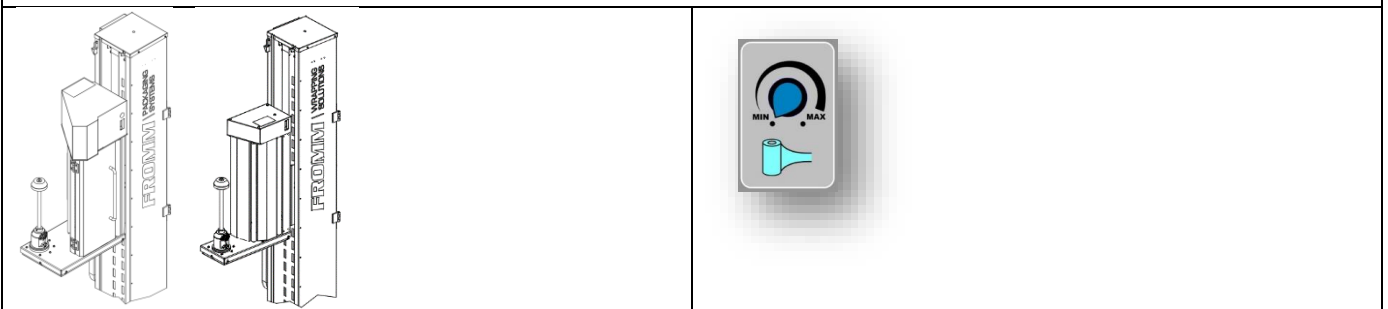

- Adjustment of the film tensioning between the carriage and pallet via a potentiometer on the control panel.



5.3. POWER SUPPLIES



Furthermore, the safety measures and directions against residual risks must be complied with during operations, see **chapter 4**.

Residual risks	PPE to be used			
				
Electric shock	Protective gloves	Body protection	Safety footwear	Hearing protection

5.3.1. ELECTRIC



Installation must comply with the legislation in the country where the machine is used.



To avoid dangers during normal operation and bad operation of assembled and connected components in the external energies power supply systems, the utmost attention is required in their installation and design.

Check, beforehand, **that the electrical system of the user**, guarantees the technical requirements listed in chapter 2 and those below.

All operations concerning connection of the machine to external power supplies are **the exclusive responsibility of the machine user's electrician**.

USER'S ELECTRICAL SYSTEM

In accordance with IEC 3644 / HD 384 / IEC 64-8 (last editions), **the user's system upstream of the machine's command and control** equipment must be designed, installed and serviced in compliance with the applicable provisions of the safety rules for "low-voltage user electrical system".

In accordance with IEC 364_4_41 / HD 382_4_41 / IEC 64-8 (4_41) (last editions), it is compulsory for **the energy distribution electrical system powering the machine command and control equipment** to fully/regularly belong to **one of the TT or TN or IT normalised systems**.

In accordance with IEC 364-5-54 / HD 382-5-54 / IEC 64-8 (5-54) (last editions), with regard to the above provisions-indications, **the related earthing system** must fully conform to the applicable requirements for coordination with the associated active devices.

EQUIPOTENTIAL PROTECTION CIRCUIT

To prevent dangerous contact voltages in the event of an insulation fault between live parts and earth, earth-to-earth voltage, untimely confirmations or inhibitions that may occur on the command circuits following a succession of earth faults, **all the earthing points on the machine are connected** to the equipotential node of the PE terminal in the main casing.

PERSONAL PROTECTION AGAINST INDIRECT CONTACTS

In the event of failure, protection measures against indirect contact by automatically interrupting the equipment's power supply circuit, consist in interrupting one or more line conductors by means of a protective device automatically intervening.

This disconnection must be triggered in a sufficiently brief time to limit the duration of the contact voltage so it is not dangerous. The interruption times are indicated in Standard IEC 3644 / HD 384 / IEC 64-8 (last editions).

ELECTRICAL POWER SUPPLY ISOLATION DEVICE

An isolation device for the electric equipment has been provided to be able to intervene without risk of electric shocks.

As proven by the power circuits diagram delivered with the electrical equipment, the power supply isolation device is supplied for sole **machine power supply source**.

Have maintenance personnel replace the mains socket with other of suitable type, if mains socket and appliance plug are incompatible.

In order to intervene without risk of electric shocks, the power supply isolation device allows **separating (isolating) the machine electrical equipment** from the power supply.

The isolation device has two possible positions:

OFF or “disconnected”
the electrical equipment is **disconnected** from the electricity supply (vertical bar)



ON or “engaged”
electrical equipment **live**
(horizontal bar)

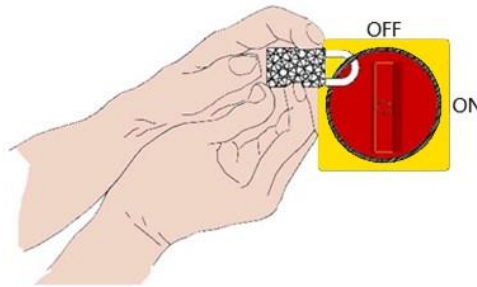

The means to prevent accidental and/or incorrect closure of the isolation device (padlock and relative key) are supplied with the device

CHAP.6 USING THE MACHINE

6.1. DESCRIPTION OF ACTUATORS, SIGNS AND ALARMS

6.1.1. COMMAND AND SIGNALLING ACTUATORS



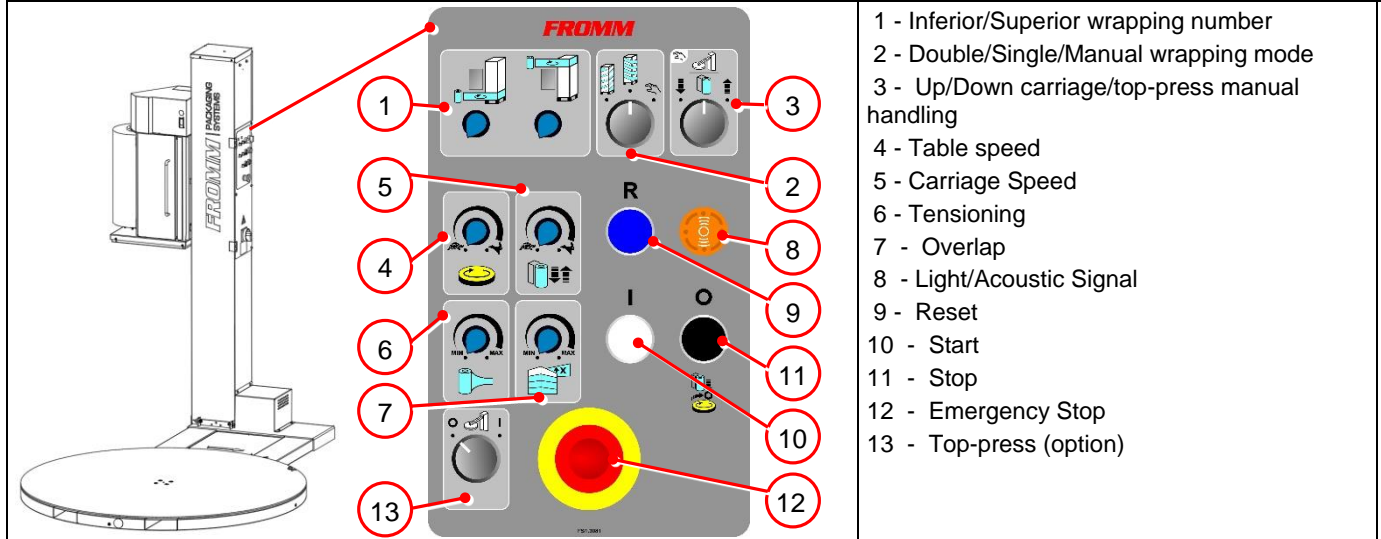

For clear and univocal reference, all work and control stations including those for emergency stops only and relative location, with references to the layout attached to the wiring diagram provided with the machine, are given below.





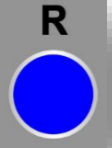

CONTROL PANEL

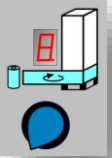

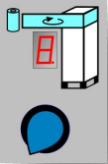
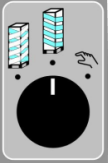

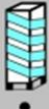
The relative Indicator (8) will emit an acoustic-light signal upon switching on the machine.

REF.	DESCRIPTION
	<p>START button</p> <p>When pressing the Start button, the machine will emit three acoustic/light beeps to warn the operator a cycle is about to start and to enable him/her to leave the dangerous area before movement starts.</p> <p><u>MANUAL mode</u></p> <ul style="list-style-type: none"> - <u>By pressing the Start button once for less than 3 seconds:</u> the table will start to rotate continuously (speed set via the relative potentiometer) until the Stop button is pressed; - <u>By pressing the Start button for more than 3 seconds:</u> the table will start to rotate (at a reduced speed) until said button is released, JOG mode. <p><u>AUTOMATIC mode</u></p> <p>By pressing the Start button, the machine will execute the cycle set via the control panel. By pressing the Start button once with the cycle frozen, the cycle is reactivated.</p>

REF.	DESCRIPTION
	<p>STOP button</p> <p><u>MANUAL mode</u></p> <ul style="list-style-type: none"> - <u>By pressing the Stop button once for less than 2 seconds:</u> the table will stop in the zero position (stop in phase); - <u>By pressing the Stop button twice within 2 seconds:</u> the table will stop according to its ramp; - <u>By pressing the Start button for more than 2 seconds while the machine stopped:</u> 3 acoustic / light beeps are emitted, the table will be brought back to the zero position (in phase). <p><u>AUTOMATIC mode</u></p> <ul style="list-style-type: none"> - <u>By pressing the Stop button once for less than 2 seconds:</u> the table will stop in the zero position (stop in phase) and the carriage will stop according to its ramp; - <u>By pressing the Stop button twice within 2 seconds:</u> the cycle in progress is frozen (1 acoustic / luminous beep every 3 seconds), pressing Start restarts the cycle; - <u>By pressing the Start button for more than 2 seconds while the machine stopped:</u> a continuous long acoustic/light signal is emitted, the table and carriage will be brought back to the zero position (in phase).
	<p>MUSHROOM-SHAPED EMERGENCY button</p> <p>An Emergency Stop is obtained when pressing this button. To re-enable it, restore the Mushroom-shaped button and press the Reset button.</p>
	<p>RESET button</p> <p>When an error leads to the machine stopping, once the cause of the error has been removed, the Reset button must be pressed to restore the power supply to the panel. A long acoustic/light signal is emitted as confirmation.</p>
	<p>ACOUSTIC/LIGHT INDICATOR</p> <p>The Acoustic/Light indicator signals the start of an Automatic cycle, the start of the table in Manual mode, the beginning of the manual table movement in Jog mode, the start of the Position Reset procedure and the occurrence of any error (the no. of beeps corresponds to the error number).</p>
	<p>LOWER WRAPPINGS</p> <p>Potentiometer with display to set the number of lower wrappings.</p>

REF.	DESCRIPTION
	<p>UPPER WRAPPINGS Potentiometer with display to set the number of upper wrappings.</p>
	<p>AUTOMATIC/MANUAL Switch the selector to choose the operating mode.</p> <ul style="list-style-type: none">  <ul style="list-style-type: none"> • Left position -> Up/Down Automatic operating mode with wrapping when the carriage moves both upwards and downwards.  <ul style="list-style-type: none"> • Central position -> UpOnly Automatic operating mode with wrapping only when the carriage moves upwards.  <ul style="list-style-type: none"> • Right position -> Manual operating mode.
	<p>TABLE SPEED potentiometer Use the potentiometer to set the table rotating speed. Between 6 and 12 rides per minute.</p>
	<p>CARRIAGE SPEED potentiometer Use the potentiometer to set the carriage ascent/descent speed. Between 2 and 4 m/min.</p>
	<p>FILM TENSIONING potentiometer (only with carriage C3 and C4) Use the potentiometer to set the tensioning of the film between the carriage and pallet.</p>

REF.	DESCRIPTION
	<p>OVERLAP function The Overlap function enables wrapping beyond the pallet height. This potentiometer also sets the entity of said overlap. Top-press active, the Overlap function will be disabled.</p>
	<p>CARRIAGE / TOP-PRESS MANUAL HANDLING selector Use this return-to-centre selector to choose between an upward or downward carriage / top-press movement. As these are manual movements, they are only allowed if the machine is set to Manual mode.</p> 

6.1.2. START-UP FUNCTIONS

All the start-up functions can only work if the corresponding circuit is powered.

Operation start is only possible if all safety protections are present and operational.

For manual and automatic start-up mode, refer to chapter 6.



The operator must never start and run the machine when it is not in the provided normal operative conditions.



CLOSE the general isolator switch of the E.P. turning it to ON/1

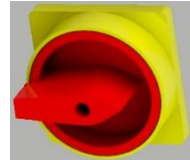

Upon start-up, the machine will display the set parameters.

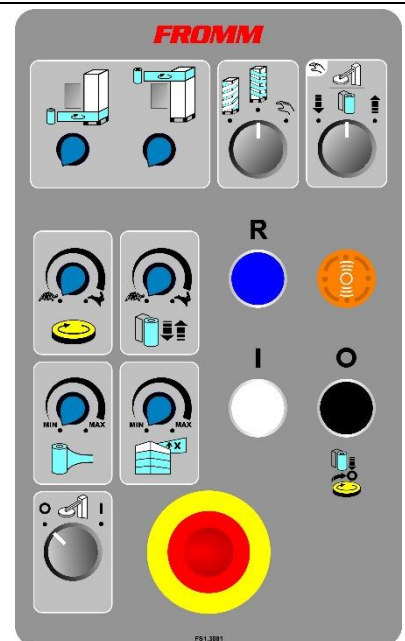

Press Start on the control panel.

The machine will start following the operating mode and parameters set.

In case of a frozen cycle, pressing the Start button will resume the cycle.



6.1.3. SETTING OF PRODUCTION / PROGRAMMING PARAMETERS



Before starting the processing cycle, set the parameters on the control panel depending on what you want to obtain.



Below is a list of all **the adjustment and tuning interventions** to be carried out before and during the production cycle, and which can be performed **by the machine operator** in accordance with the indications given (see chapter 6.).

6.1.3.1. LIST OF ALARMS

The machine is also equipped with a self-diagnostic system, sensors send signals to the system if any anomalies occur.

The system uses codes to find the anomaly, the following table contains the codes, the type of anomaly that caused the alarm and the actions to perform.

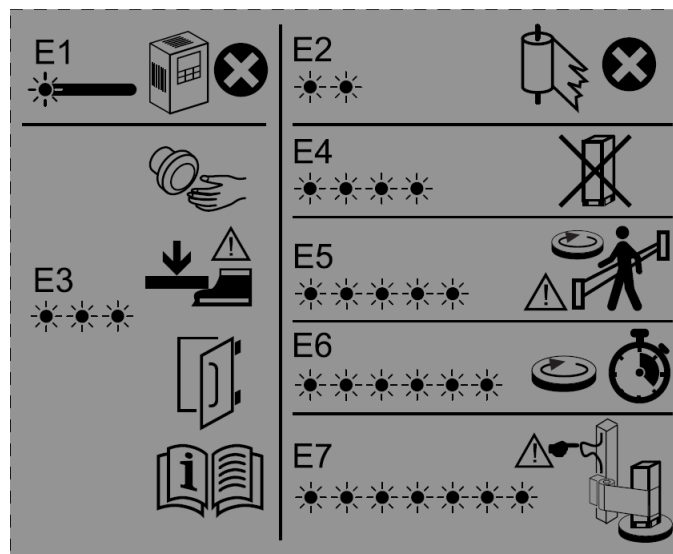

Code	Signal	Cause	Actions
E1	1 x continuous acoustic/light signal	Inverter Error	Turn machine off and on. If the error persists, call the Service.
E2	2 x acoustic /light impulse (repeated sequence)	Film breakage	Reapply the film to the pallet and press Start.
E3	3 x acoustic /light impulse (repeated sequence)	Safety Contacts	Resolve the error restoring the following safety devices: Emergency button, Toe Board, Carriage Door Closure (one on carriage C2/C4 and 2 on carriage C3), Hand protection (carriage C1 only), Safety Mat (only for table with a 1650 mm diameter), Table Barrier Open. Press the Restore Button.
E4	4 x acoustic /light impulse (repeated sequence)	Pallet not detected	Place the pallet on the table and press Start.
E5	5 x acoustic /light impulse (repeated sequence)	Table Barrier Open	Remove the obstacle at the Table Open entrance. Press the Restore Button.

E6	6 x acoustic /light impulse (repeated sequence)	Table Time Out	Call the Service Centre.
E7	7 x acoustic /light impulse (repeated sequence)	No Belt Voltage	Call the Service Centre.

6.2. PROCESSING CYCLE

1. Load the reel if necessary and insert the film along the way.
2. Start up the machine as indicated in the "Start-Up Functions" paragraph.
3. Prepare the machine with the desired setting.
4. Start up the machine as indicated in the "Start-Up Functions" paragraph.



Automatic Up/Down • cycle

Selector in left position -> **Up/Down Automatic** operating mode with wrapping when the carriage moves both upwards and downwards.

Operation: Upon START, the carriage moves from the Carriage ascent Height downwards to the lower position, the table starts rotating and as many table rides as the ones set in the Low Ride Number are performed. Afterwards, the table keeps rotating and the carriage moves upward until the Pallet Height Photocell identifies the top limit of the goods to be wrapped: at this point, the carriage stops while the table continues rotating performing as many table rides as the ones set in the High Ride Number. After that, while the table is still rotating, the carriage starts moving downwards to the bottom position where it stops. The table stops in the zero position. When the table stops, the carriage starts moving upwards as far as the carriage Ascent Height. Cycle end.

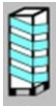

Automatic Up Only • cycle

Selector in the central position -> **Up Automatic** operating mode with wrapping only when the carriage moves upwards.

Operation: Upon START, the carriage moves from the Carriage ascent Height downwards to the lower position, the table starts rotating and as many table rides as the ones set in the Low Ride Number are performed. Afterwards, the table keeps rotating and the carriage moves upward until the Pallet Height Photocell identifies the top limit of the goods to be wrapped: at this point, the carriage stops while the table continues rotating performing as many table rides as the ones set in the High Ride Number. At this point, the table stops in phase: the carriage starts moving downwards to the bottom position where it stops and starts moving upwards until the carriage Ascent Height. Cycle end.



Manual • Operating Mode

Selector in the right position -> **Manual** operating mode.

Operation: The table starts rotating upon START. The carriage/top-press can be moved upwards or downwards via the Carriage/Top-press Manual Movement selector: the movement will continue as long as the selector is actioned. Press Stop once to stop the table in phase, press it twice to stop it immediately. Press Stop once to stop the table in phase, press it twice to stop it immediately.

6.3. CYCLE STOP



The emergency stop or activation of any safety device must not be used to stop the working cycle.

STOP FUNCTIONS

<p>STOP IN PHASE By pressing the Stop button once.</p>	
--	---

The machine can also stop after an alarm.

6.4. SWITCH-OFF



Using the STOP button, always control the machine processing cycle end before switch-off.
Finally, the isolation devices of the machine external energy sources power supply, must always be placed at "OFF" or "CLOSED".



OFF or "disconnected"
the electrical equipment is
disconnected from the
electricity supply (vertical
bar)

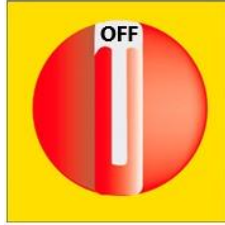

ON or "engaged"
electrical equipment
live
(horizontal bar)

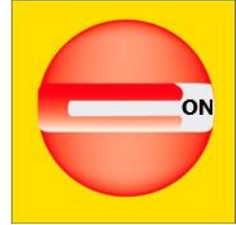

CHAP.7 MAINTENANCE



“Maintenance” does not merely refer to the periodic checking of correct machine operation; it also involves the analysis and consequent solution of any situation that puts the machine out of action. The maintenance entails a range of significant mechanical and electrical problems requiring the operator to have good theoretical-practical knowledge of the machine.



Namely, personnel responsible for maintenance must have the following objectives:



1. limit decay of parts subject to wear
2. reduce accidents to a minimum
3. contain costs for accidental faults
4. limit number and duration of interventions
5. collaborate with operators.

The maintenance technician must respect some essential rules to obtain said objectives, namely:

1. fill-in maintenance sheets relating to the various machines with the type and frequency of interventions carried out or to be carried out
2. carry out lubrication programs timely
3. collaborate in defining and managing spare parts, stressing their replenishment as soon as the minimum established is reached.

For maintenance activities performed by the user, this task must be assigned to personnel identified as specified in chapter no. 2.

In addition to having the characteristics described in chapter 4, personnel carrying out the operations herein must have read and understood the safety provisions set forth in chapter 4.

A maintenance contract must be stipulated with specific companies, like the electrical equipment's manufacturer, if the user does not have adequately trained and expert or warned personnel.



Certain scheduled maintenance operations forming part of the routine maintenance procedures, the execution of which does not call for special professional skills, can be carried out **by trained although non-expert personnel**, or by machine operators, who are always informed or, if necessary, supervised by a maintenance technician to avoid or prevent hazards relating to the overall machine.



7.1. ROUTINE MAINTENANCE



In addition to having the characteristics described in **chapter 4**, personnel carrying out the operations herein **must have read, understood and must observe** the safety provisions set forth in **chapter no. 4**, namely:



1. stand-by of stop times before introducing limbs or body parts inside the machine dangerous areas
2. use of adequate protection devices and safety accessories for cleaning inside the machine danger zones.



Residual risks



Risk of hitting your head



Risk of burns



Risk of cuts



Risk of crushing of the hands

PPE to be used:



Eye protection



Protective gloves



Safety footwear



Body protection



Mouth and nose protection: mask (category II)



Hard hat

It is forbidden to perform any repair or adjustment **on moving parts**.

Disconnect and isolate the external power supply sources before carrying out any **maintenance, cleaning and parts replacement** (see **chapter 7**).



The greatest the care in adjustments, registration and routine/scheduled maintenance, the longer the machine will preserve its features unaltered and extraordinary maintenance/repair interventions will decrease.



According to the indicated periodicity, carry out all verifications, checks and cleaning in **this chapter**.

However, **general rules must be respected** to maintain the machine in perfect starting order:

1. keep the machine clean and tidy
2. avoid every preventive damage
3. avoid temporary or emergency repairs become normal
4. avoid carrying out work on the machine that produce mechanical chippings; carefully check no fragments remain on the machine parts if, for example, there is a need to make holes.

For the disposal of worn or replaced materials, refer to chapter 8.

Both the operator and maintenance technician must carefully follow the prescriptions, during all interventions.

7.1.1. INTERVENTIONS EXECUTABLE BY THE OPERATORS



All **periodical checks/inspections, adjustment and calibration operations**, and **ROUTINE MAINTENANCE** operations that may also be carried out by the **machine operator**, in accordance with the requirements referred to in chapter 4.

FREQUENCY	VERIFICATION	METHOD AND CHECKS
Before every work shift	Check the proper functioning of: <ul style="list-style-type: none"> of the emergency stop button 	Verify that error E3 occurs when the emergency button is pressed. Restore the emergency button and press the blue reset button. Provide a control procedure to verify the perfect electrical and mechanical functionality of the devices, to by-pass any problem on its arising . The actuators and all parts must be immediately replaced when appearing broken or corroded. Activate the maintenance service for any intervention or parts replacement. Parts replacement must always be carried out using the manufacturer's original parts, or at least parts of equivalent quality and safety levels.
Before every work shift	Visual integrity check: <ul style="list-style-type: none"> of fixed guards of movable guards. 	All fixed guards must be present and properly fixed in position. Verify their integrity and the absence of signs of erosion or breakage. Activate the maintenance service for any intervention or parts replacement.
At least once a week	Visual integrity check <ul style="list-style-type: none"> all plates. 	If illegible, they are requested from the manufacturer or replaced by the user with others having identical information as indicated in chapter 4.
Following the actioning of the emergency button	Check the causes that led to the actioning of the device	Detect the causes that determined the actioning of the emergency stop device: <ol style="list-style-type: none"> If the emergency stop device has been actioned incorrectly, reset the machine and restart. In the event that the emergency stop device has been activated following a situation of danger, failure, malfunction, contact the maintenance service or the manufacturer of the machine to eliminate the condition. Only after the complete resolution of the fault or malfunctioning situation, reset the machine and restart.



Any replacements must be made with the manufacturer's original products or, at least, of equivalent quality and safety: the installation of non-original products or self-made, will void the machine warranty.

The replacement instructions are not given in this manual and must be explicitly requested from the machine manufacturer, who is **responsible for the replacement interventions**.

7.1.2. INTERVENTIONS EXECUTABLE BY MAINTENANCE TECHNICIANS ONLY



Below are the **ROUTINE MAINTENANCE** operations that must be carried out by **maintenance technicians** as defined in chapter 7.



The replacement instructions are not given in this manual and must be explicitly requested from the machine manufacturer, who is **responsible for the replacement interventions.**

FREQUENCY	VERIFICATION	METHOD AND CHECKS
At least monthly	The inside of the casings and motor compartments	All the inner parts of the casings, along with the machine compartments housing the motors, must be kept clean and dry . Use suitable and common means (e.g. a vacuum cleaner and dry brush for dust, and absorbent cloths for any possible water) to keep these areas clean.
Monthly - 500 cycles	Safety checks	<p>Activate the safety devices one at a time (emergency mushroom button, carriage doors, toe board) and verify that the actioning of each device provokes alarm E3. Reset the safety device actioned, press the reset button and reactivate machine functioning: repeat said procedure for each safety device.</p>
At least quarterly	<p>Check the reliability and functioning of:</p> <ul style="list-style-type: none"> of the general contactor, micro switches and proximity switches; 	<p>By visually inspecting the relay contacts, ascertain the state of the power contacts of contactors, micro switches and proximity switches, channelling and internal and external duct casings.</p> <p>In order to guarantee correct operation, the above, the unipolar and/or multipolar cables, must be replaced if not in normal conditions.</p> <p>Check adequate distances of the cams for micro switch activation. Immediately suspend processing to machine and contact the machine manufacturer, if these are absent or no longer in their original position.</p>
At least quarterly	<p>General checks</p> <ul style="list-style-type: none"> of electric equipment 	<p>Check the full electric equipment, cabinet and on-board machine for operation and service continuity requirements.</p> <p>The efficiency of the acoustic light device must also be checked. In case of malfunction, it must be replaced with an identical model.</p> <p>Ensure electrical equipment parts subject to wear, such as for instance mobile laying cables and power supply cables are intact and in good working order, otherwise replace them.</p>

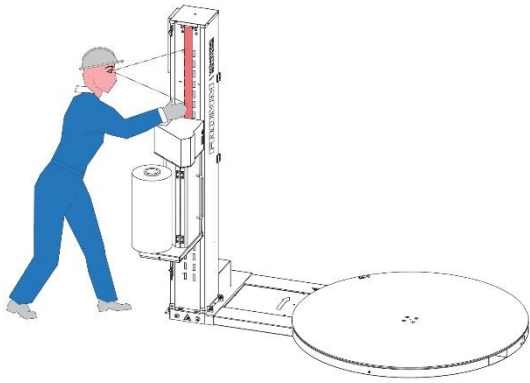
<p>Every 6 months - 3000 cycles</p>	<p>Check the state of the lifting belt</p>	<p>Shut off the machine and disconnect the power supply cable. Check the integrity of the lifting belt making sure it shows no sign of deterioration, abrasion or fraying.</p>  An illustration showing a worker in a blue uniform and a grey cap inspecting a vertical lifting mechanism. The worker is looking at a red vertical scale on the machine. The machine has a cylindrical component and a large circular base. The worker is holding a small rectangular object, possibly a tool or a part of the machine, near the scale.
--	---	---

FREQUENCY	VERIFICATION	METHOD AND CHECKS
<p>At least quarterly</p>	<p>Check reliability and functionality</p> <ul style="list-style-type: none"> • of guards of safety devices 	<p>All indicated guards and devices and circuits must perform the function for which they were intended. Directly control the devices so they cause the awaited function/signal.</p> <p>The necessary inspections relate to:</p> <ol style="list-style-type: none"> 1. loss or damage of any part of the guard, specifically if this decreases the safety functions, like reduction of resistance to impacts 2. replacement of parts subject to wear 3. deterioration of junctions or fixing points 4. deterioration due to corrosion, change in temperature or chemical effects 5. satisfying operation and lubrication of mobile parts, if required 6. change of safety distances and dimensions of the openings 7. deterioration of acoustic behaviour. <p>Replacement must take place when at least one of the indicated components is anomalously worn, cracked, corroded or broken.</p> <p>Parts replacement must always be carried out using the manufacturer's original parts, or at least parts of equivalent quality and safety levels. Contact the manufacturer directly.</p>
<p>At least six-monthly</p>	<p>Check efficiency motors electric insulation</p>	<p>The motors insulation resistance must be measured and checked using adequate instrumentation so that the measured values fall within the acceptable limits defined by the installation standards and in accordance with the current dispositions in the place of installation.</p>
<p>At least six-monthly</p>	<p>Check efficiency of the protection and equipotential circuit connections</p>	<p>The resistance to the equipotential and protection systems mass and of ever connection must be measured and checked using adequate instrumentation, so that the measured values fall within the acceptance limits defined by the installation standards and in accordance with the current dispositions in the place of installation.</p> <p>In accordance with IEC364_5_54 / HD382_5_54 / IEC 64.8 (5_54) (latest editions), with regard to the above provisions-indications, the related earthing system must fully conform to the applicable requirements for coordination with the associated active devices.</p>
<p>Yearly</p>	<p>Check reliability and functionality of machine components</p>	<p>After one year of activity, it is possible that elements under stress during the production cycle will have to be replaced or regenerated. Depending on the type of extraordinary intervention, the client can decide to:</p> <ul style="list-style-type: none"> ➤ Replace the parts by ordering original spare parts (client responsibility in case of erroneous installation) ➤ Require the intervention of a manufacturer's technician in case of extensive and complicated interventions. ➤ Send the machine to the manufacturer for an accurate complete regeneration. <p>N.B.: should the client decide to perform the replacement interventions autonomously, skilled technicians able to perform the operations necessary are needed. The manufacturer declines all liability for any malfunction and/or damage and/or production not compliant with the standards in case of extraordinary interventions performed by unauthorised personnel.</p>
<p>At least once a year</p>	<p>Check efficiency of connections and electric components in and out of casings</p>	<p>Check no looseness is present. Reset connections if present, by tightening them with adequate torque moment and directly reported on the electric components.</p> <p>The check must also refer to:</p> <ol style="list-style-type: none"> 1. the integrity of the junction boxes, of the casings, of the pushbutton control panels and electric cables' protection sheaths 2. functionality of all power and control actuators.

7.2. EXTRAORDINARY MAINTENANCE



For some interventions referred to in this paragraph, **you may need to remove some fixed guards and protective devices from their position. Only the maintenance technician can remove them.**



At the end of these interventions, those guards and protective devices should be repositioned and locked in their original position, with the fastening systems that were provided before the intervention. For further information on the guards and protective devices present on the machine, see chapter 4.

The maintenance manager must fully disable the machine, among other tasks already mentioned, before removing a fixed guard and/or replacing an element of the machine.

7.2.1. OPERATIONS THAT CAN ONLY BE PERFORMED BY MANUFACTURER TECHNICIANS



Below are the **EXTRAORDINARY MAINTENANCE** operations that must be carried out by **manufacturer technicians** as defined in chapter 7.

For extraordinary maintenance operations, we recommend always contacting FROMM. In conditions of correct use and maintenance, the machine does not generally require substantial servicing operations. In case of anomalies, contact the FROMM service centre.

FREQUENCY	VERIFICATION
Every 12 months - 6000 cycles	➤ Table fixing bolts
	➤ Table rotation chain greasing
	➤ Table rotation chain tension
	➤ Wear of the table rotation chain
	➤ Wear of the rotating table wheels
	➤ Wear of the open table traction rubber wheels
Every 24 months - 12000 cycles	➤ Replace the rotary table wheels
	➤ Replace the carriage lifting wheels
	➤ Replace the carriage lifting reducer

The Frequency of the interventions is estimated considering 20 wrappings/day, 25 days/month. The timings in cycles were defined based on a standard cycle. A standard cycle is considered as follows: film reel with a height of 500 mm, pallet height 1500 mm, pallet weight 1000 kg, up/down wrapping cycle, two lower rolls, two upper rolls, table rotation speed 12 rpm, carriage ascent and descent speed 4 m/min.

In case of heavy-duty operation, increase the frequency of the checks by halving maintenance intervals. A heavy-duty operation is considered as follows:

- Operating temperature < 10°C
- Number of packages > 20 / day
- Pallet weight > 1000 Kg
- Dusty environment.

7.3. CLEANING



Do not clean, oil or grease the machine's moving organs and elements by hand. The following section describes **cleaning** operations that can be **performed by maintenance technicians** with the professional qualifications as defined in chapter 7.



Normally, certain cleaning operations **can be performed by the machine operator**, i.e. normal operations on the outside of the machine, calling for the use of simple personal protective equipment. **Cleaning operations of the internal machine parts** must be performed by the maintenance service.



Cleaning should be carried out by the machinery operating personnel, instead of contract cleaners' personnel, whom cannot guarantee respecting all recommendations present, in order to avoid inopportune and dangerous machine unwanted activations or undue changes, even unwanted or accidental.



All cleaning operations must only be carried out **after having isolated and discharged the machine from the external energy supply sources** (chapter 7).



Never use petrol, solvents or flammable and/or corrosive fluids to clean the machine, its components and the electric equipment. **Use non-flammable and non-toxic, commercial and approved solvents.**



Respect the use methods and use any PPE provided by the supplier of said substances.

The machine, the electric equipment and the machine components must never be cleaned using water, or jets of any nature and quantity; therefore without "bucket" or "hose" or "sponge".



Residual risks



Risk of hitting your head



Risk of burns



Risk of cuts



Risk of crushing of the hands

PPE to be used:



Eye protection



Protective gloves



Safety footwear



Body protection



Mouth and nose protection: mask (category II)



Hard hat



For disposal of waste that came into contact with the medical liquid product, refer to the product's technical and safety data sheets, which the employer must attach to this document.

Also refer to regulations in force on disposal in the country of use of the machine.

FREQUENCY	PERSONNEL	AREA - MODE/METHODS
At end of shift	The operator also	<p>The work place and the control station must be kept clean and tidy. Untidiness leads to danger of accidents.</p> <p>Use dust-proof masks and the other PPE prescribed for type of intervention and based on the cleaning substances used.</p> <p>Respect the use methods and use any PPE provided by the supplier of said substances.</p>
At least weekly	The maintenance technician	<p>Of the photocells reading heads, sensors in general, remove dust and foreign staining substances: use vacuum cleaner and/or dry brush.</p> <p>Use dust-proof masks and the other PPE prescribed for type of intervention and based on the cleaning substances used.</p>
At least weekly	The operator also	<p>Clean the parts outside the EP using a soft and dry cloth that does not leave its fibres on the EP surface and on the components installed on the machine: use a vacuum cleaner and/or a dry brush.</p> <p>Do not use abrasive products, coloured substances, wire scourer, brushes, scrapers, etc.</p> <p>Respect the use methods and use any PPE provided by the supplier of said substances.</p>
Monthly - 500 cycles	The operator also	<p>Shut off the machine and disconnect the power supply cable.</p> <p>Open the carriage door and clean the rubber rollers with a damp cloth</p> 

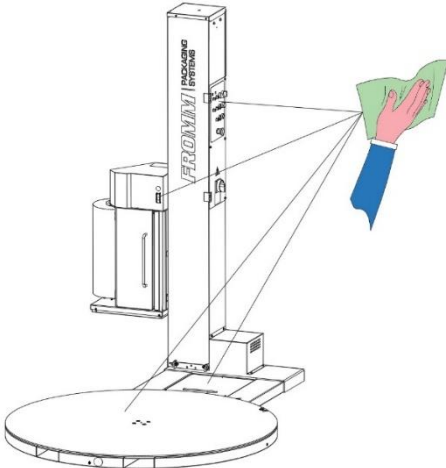
<p>Monthly - 500 cycles</p>	<p>The operator also</p>	<p>Shut off the machine and disconnect the power supply cable. Clean the machine with a dry cloth.</p> 
<p>At least six-monthly</p>	<p>The maintenance technician</p>	<p>Rust formed during transport or storage must be removed from the non-painted parts. Use specific anti-rust substances for this operation. Respect the use methods and use any PPE provided by the supplier of said substances.</p>

ATTENTION:
Failing to observe this provision leads to an immediate cancellation of the warranty established by the contract.

CHAP.8 DEMOLITION AND DISPOSAL



Decommission the machine object of this manual, **making it unusable and without potential dangers**, if it becomes obsolete and/or is irreparably faulty or worn, so far to make its repair uneconomical.



The machine must be decommissioned by **specialized and equipped personnel**.

Contact the machine manufacturer's technicians if the customer does not have suitable instrumentation or personnel for a safe demolition and to guarantee operator safety.

Signal interventions in progress before starting **demolition**.



8.1. DEMOLITION



The **areas around the machine** for an area of 360°, must be free from walls, other machinery, equipment or other encumbering elements like columns, for at least 2000mm, to be able to safely perform interventions.



The main sequential phases for disassembly and dismantling include (indicative non-exhaustive list): disassemble all components and send them to separate collection companies or bodies, in compliance with current standard.



Based on the type of screws, all disconnection operations must be carried out using **adequate tools of adequate dimensions** (e.g. screwdriver or Phillips screwdriver, hex wrenches, Allen wrenches, etc.).



Do not, for any reason, enter the machine, go underneath it or above it, **during disassembly**: always remain at the side of the machine.



Ensure the connected parts cannot fall on you, before disassembling any part and/or disconnect and/or loosen any joining element.

To do this, use the necessary supports, auxiliary restraints or lifting devices that are type-approved and certified in compliance with statutory legislation in force in your country.

Never attempt to disassemble the machine unaided; **always obtain the assistance** of someone to help with the operations and/or provide aid in the event of errors. This person must at least have the professional skills of a maintenance technician, as defined in chapter 7.

Pay special attention to **any labels affixed** directly to the components to be disconnected, or near terminal boards (see chapter 4).

At the end of the disassembly operations, all the identification plates of the machine and electrical equipment - and any other documents relating to them - must be destroyed.

8.2. DISPOSAL



Before performing the operations to dispose of the components that make up the machine and electrical equipment, consult with the machine manufacturer (refer to chapter no. 9), who will provide the **operating modes in observance of the principles of safety and environmental protection.**



The machine **can be disposed of without having to break it down into tiny pieces**; simply separate the main units and load them onto a lorry for transfer to a waste disposal facility.



However, suitable, approved and certified in accordance with the current regulations and legislative dispositions lifting and movement means are required, such as forklifts, tackles, cranes and movable bridge, etc.

Dispose of the materials in compliance with the applicable regulations, seeking the assistance of the delegated authorities and/or companies specialised in the disposal of industrial machines and/or waste. Ensure that plastic materials, metal materials and electric components are properly separated **for differentiated disposal.**

The employer **must be aware of the statutory legislation in force in the country of use, and must comply with such provisions.**

The act of abandoning the machine and electrical equipment in the environment **is forbidden, and may be subject to penalties.**

CHAP.9 IDENTIFICATION DATA

9.1. MANUFACTURER

FROMM SLOVAKIA a.s.
Priemyselna 5885 - 90101 Malacky Slovakia
Tel. +421 34 772 3824 +421 34 772 3845 - Fax +421 34 772 3851
E-mail: sk@fromm-pack.com
Web-site: www.fromm-sk.sk

9.2. MACHINE TYPE

Generic/trade name	FS MACHINES
Function	PALLET WRAPPING MACHINE
Model	FS360
Serial number	SEE LABEL ON THE MACHINE
Year of manufacture	20..

9.3. DOCUMENT

OPERATING MANUAL
Volumes no.: 1
Date: 04/08/2020
Revision: 00

© Copyright 2019 – FROMM Holding AG

This manual, or any part of it, cannot be reproduced in any form, modified, transcribed, translated into any language, made available to third parties or used in any way that jeopardises the interests of FROMM Holding AG, without its written authorisation.

Any abuse will be persecuted by law and on copyright.